



SD QATAR uPVC PIPES & FITTINGS

BSI KITEMARK LICENCED

UNDERGROUND DRAINAGE
ABOVEGROUND SOIL, WASTE & VENTILATION SYSTEMS

PRODUCT CATALOGUE

صنع في قطر
MADE IN QATAR

CONTENTS

TITLE	PAGE
COMPANY PROFILE	1
SD QATAR ABOVE GROUND, SOIL, WASTE & VENTILATION SYSTEMS	2
ISO 9001 : 2008 CERTIFICATION	12
KITE MARK BSEN 1401 & BSEN 1329 CERTIFICATIONS	13
SD QATAR UNDERGROUND DRAINAGE SYSTEMS	14
ADVANTAGE OF USING SD QATAR PIPES & FITTINGS	24
THERMAL EXPANSION & CONTRACTION, PIPE LINE DESIGN	26
RELATED STANDARDS (EUROPEAN & BRITISH STANDARDS)	27
INSTALLATION METHODES OF SD QATAR PIPES & FITTINGS	28
INSTALLATION OF UNDERGROUND PIPING SYSTEM (TRENCHING)	29

QATAR PIPELINE AND FITTINGS COMPANY

We Qatar Pipeline & Fittings Company were established in the year 1999 looking forward to be among the pioneers in plastic industry specifically on the production of plastic pipes & fittings in the state of qatar on the twenty first century.



To achieve our goals we have worked within the basics of supplying high quality products that met the desires & the specifications of our customers from both public & private sectors.

We were the first in our field to achieve the iso certification of ISO 9001 : 2000 on the year 2003 later recertified to ISO 9001 : 2015 on 2019.

On our continual improvement plans, we succeeded on the year 2007 to introduce the first & the only pvc fittings plant that produces pvc fittings in accordance to BS EN 1401 & BS EN 1329 for Underground & Above ground drainage & sewerage systems in Qatar.

On 2010, we were able to achive the british standards institute (BSI) products quality certification well known as the kite mark for both standards.



Our product is proudly holding our country name as part of it (SD QATAR) & We assure to keep this name on the top of all by maintaining the best quality & securing our customers with only the best.

SD QATAR ABOVE GROUND SOIL WASTE & VENTILATION SYSTEMS

BS EN 1329

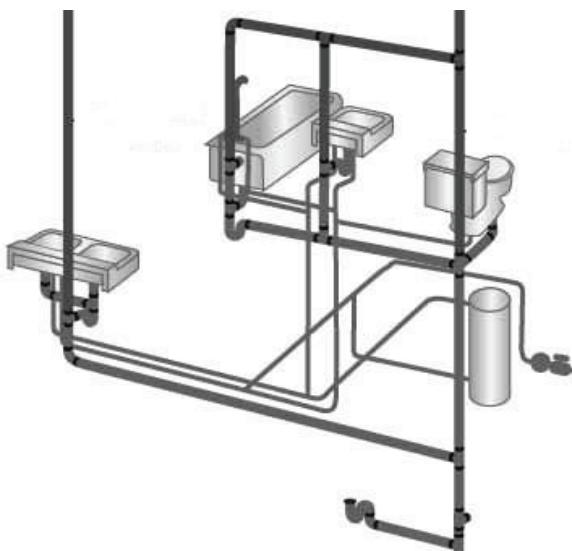

KITE MARKED BSI uPVC
DRAINAGE/SOIL & WASTE
PIPE & FITTINGS



ABOVE GROUND SOIL, WASTE & VENTILATION SYSTEMS

SD QATAR BS EN 1329 (Formerly BS 4514)

DESCRIPTION	MINIMUM WALL THICKNESS	SIZE		CODE
		mm	Inch	
 RUBBER SOCKET uPVC PIPE	3.2 mm	110	4"	PSD41G
	3.2 mm	160	6"	PSD61G
 SOLVENT SOCKET uPVC PIPE	3.2 mm	82	3"	PSD34G
	3.2 mm	110	4"	PSD44G
	3.2 mm	160	6"	PSD64G
 RUBBER SOCKET uPVC PIPE	4.9 mm	200	8"	PSD81G
	6.1 mm	250	10"	PSD101G
	7.7 mm	315	12"	PSD121G
 SOLVENT SOCKET uPVC PIPE	4.9 mm	200	8"	PSD84G
	6.1 mm	250	10"	PSD104G
	7.7 mm	315	12"	PSD124G
 ELBOW 45° DOUBLE SIDE RUBBER SOCKET		82	3"	BD3G
		110	4"	BD4G
		160	6"	BD6G
 FLOOR TILE GRATE		110	200 x 200	FTLG8W



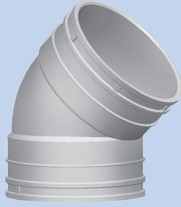
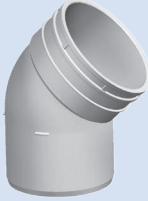
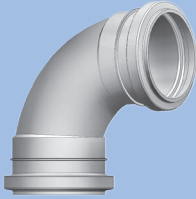

ABOVE GROUND SOIL, WASTE & VENTILATION SYSTEMS

SD QATAR BS EN 1329 (Formerly BS 4514)

DESCRIPTION	SIZE		CODE
	mm	Inch	
 ELBOW 45° RUBBER SOCKET / SPIGOT	110	4"	BD41G
 ELBOW 45° DOUBLE SIDE SOLVENT SOCKET	82	3"	BD33G
	110	4"	BD43G
	160	6"	BD63G
 ELBOW 45° SOLVENT SOCKET / SPIGOT	110	4"	BD44G
 ELBOW 90° DOUBLE SIDE RUBBER SOCKET	82	3"	EL3G
	110	4"	EL4G
	160	6"	EL6G
 ELBOW 90° DOUBLE SIDE SOLVENT SOCKET	82	3"	EL33G
	110	4"	EL43G
	160	6"	EL63G
 ELBOW 90° RUBBER SOCKET / SPIGOT	110	4"	EL41G
	160	6"	EL61G



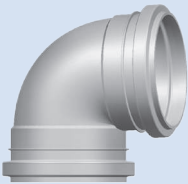

ABOVE GROUND SOIL, WASTE & VENTILATION SYSTEMS

SD QATAR BS EN 1329 (Formerly BS 4514)

DESCRIPTION	SIZE		CODE
	mm	Inch	
 <p>ELBOW 90° SOLVENT SOCKET / SPIGOT</p>	110	4"	EL44G
	160	6"	EL64G
 <p>ELBOW 90° DOUBLE SIDE RUBBER SOCKET WITH 3" ACCESS CAP</p>	110	4"	ELC4G
 <p>ELBOW 90° RUBBER SOCKET / SPIGOT WITH 3" ACCESS CAP</p>	110	4"	ELC41G
 <p>ELBOW 90° DOUBLE SIDE SOLVENT SOCKET WITH 3" ACCESS CAP</p>	110	4"	ELC43G
 <p>ELBOW 90° SOLVENT SOCKET / SPIGOT WITH 3" ACCESS CAP</p>	110	4"	ELC44G
 <p>SHORT ELBOW 90° DOUBLE SIDE RUBBER SOCKET</p>	110	4"	SEL4G

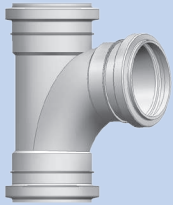

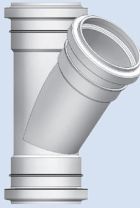

ABOVE GROUND SOIL, WASTE & VENTILATION SYSTEMS

SD QATAR BS EN 1329 (Formerly BS 4514)

DESCRIPTION	SIZE		CODE
	mm	Inch	
 <p>SHORT ELBOW 90° DOUBLE SIDE SOLVENT SOCKET</p>	110	4"	SEL43G
 <p>EQUAL TEE 87.5° ALL SIDE RUBBER SOCKET</p>	82	3"	ET3G
	110	4"	ET4G
	160	6"	ET6G
 <p>EQUAL TEE 87.5° ALL SIDE SOLVENT SOCKET</p>	82	3"	ET33G
	110	4"	ET43G
	160	6"	ET63G
 <p>EQUAL TEE 87.5° RUBBER SOCKET / SPIGOT</p>	110	4"	ET41G
	160	6"	ET61G
 <p>EQUAL TEE 87.5° SOLVENT SOCKET / SPIGOT</p>	110	4"	ET44G
	160	6"	ET64G
 <p>WYE BRANCH 45° ALL SIDE RUBBER SOCKET</p>	82	3"	YB3G
	110	4"	YB4G
	160	6"	YB6G

ABOVE GROUND SOIL, WASTE & VENTILATION SYSTEMS

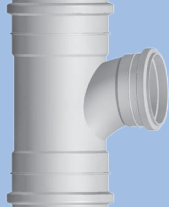
SD QATAR BS EN 1329 (Formerly BS 4514)

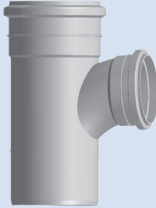
DESCRIPTION	SIZE		CODE
	mm	Inch	
 <p>WYE BRANCH 45° ALL SIDE SOLVENT SOCKET</p>	82	3"	YB33G
	110	4"	YB43G
	160	6"	YB63G
 <p>WYE BRANCH 45° RUBBER SOCKET / SPIGOT</p>	110	4"	YB41G
	160	6"	YB61G
 <p>WYE BRANCH 45° SOLVENT SOCKET / SPIGOT</p>	110	4"	YB44G
	160	6"	YB64G
 <p>REDUCED TEE 87.5° ALL SIDE RUBBER SOCKET</p>	160 X 110	6" X 4"	RT64G
 <p>REDUCED TEE 87.5° ALL SIDE SOLVENT SOCKET</p>	160 X 110	6" X 4"	RT643G
 <p>REDUCED TEE 87.5° RUBBER SOCKET / SPIGOT</p>	160 X 110	6" X 4"	RT641G

ABOVE GROUND SOIL, WASTE & VENTILATION SYSTEMS

SD QATAR BS EN 1329 (Formerly BS 4514)

DESCRIPTION	SIZE		CODE
	mm	Inch	
 <p>REDUCED TEE 87.5° SOLVENT SOCKET / SPIGOT</p>	160 X 110	6" X 4"	RT644G
 <p>REDUCED WYE BRANCH 45° ALL SIDE RUBBER SOCKET</p>	160 X 110	6" X 4"	RY64G
 <p>REDUCED WYE BRANCH 45° ALL SIDE SOLVENT SOCKET</p>	160 X 110	6" X 4"	RY643G
 <p>REDUCED WYE BRANCH 45° RUBBER SOCKET / SPIGOT</p>	160 X 110	6" X 4"	RY641G
 <p>REDUCED WYE BRANCH 45° SOLVENT SOCKET / SPIGOT</p>	160 X 110	6" X 4"	RY644G
 <p>FLOOR GULLY TRAP</p>	110	4" X 3" X 2"	FGT432G
	110	4" X 3" X 1 1/2"	FGT43G





ABOVE GROUND SOIL, WASTE & VENTILATION SYSTEMS

SD QATAR BS EN 1329 (Formerly BS 4514)

DESCRIPTION	SIZE		CODE
	mm	Inch	
 <p>LONG FLOOR GULLY TRAP 4" X 3" X 2"</p>	110	4" X 3"	LFGT43G
 <p>ECCENTRIC REDUCER RUBBER SOCKET / SPIGOT</p>	110 X 82	4" X 3"	RE431G
	160 X 110	6" X 4"	RE641G
 <p>ECCENTRIC REDUCER SOLVENT SOCKET / SPIGOT</p>	110 X 82	4" X 3"	RE434G
	160 X 110	6" X 4"	RE644G
 <p>ECCENTRIC REDUCER ALL SIDE SPIGOT</p>	82 X 50	3" X 2"	RE322G
	110 X 50	4" X 2"	RE422G
	110 X 82	4" X 3"	RE432G
 <p>REDUCER BUSH</p>	110 X 82	4" X 3"	RB432G
	160 X 110	6" X 4"	RB642G
 <p>ACCESS CAP WITH PRESSURE PLUG</p>	82	3"	ACP32G
	110	4"	ACP42G
	160	6"	ACP43G

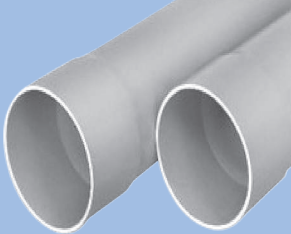
ABOVE GROUND SOIL, WASTE & VENTILATION SYSTEMS

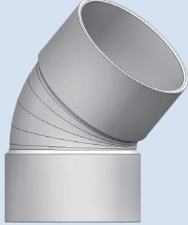
SD QATAR BS EN 1329 (Formerly BS 5255)

DESCRIPTION	MINIMUM WALL THICKNESS	SIZE		CODE
		mm	Inch	
 SOLVENT SPIGOT uPVC PIPE	1.8 mm	32	1 1/4"	PSD1Q4G
	1.9 mm	40	1 1/2"	PSD1H4G
	2.0 mm	50	2"	PSD24G
 STRAIGHT COUPLER SOLVENT SOCKET		32	1 1/4"	CO1Q3G
		40	1 1/2"	CO1H3G
		50	2"	CO23G
 ELBOW 45° SOLVENT SOCKET				
		40	1 1/2"	BD1H3G
		50	2"	BD23G
 ELBOW 90° SOLVENT SOCKET				
		40	1 1/2"	EL1H3G
		50	2"	EL23G

ABOVE GROUND SOIL, WASTE & VENTILATION SYSTEMS

SD QATAR BS EN 1329 (Formerly BS 5255)

DESCRIPTION	SIZE		CODE
	mm	Inch	
 <p>EQUAL TEE 87.5° ALL SIDE SOLVENT SOCKET</p>	40	1 1/2"	ET1H3G
	50	2"	ET23G
 <p>WYE BRANCH 45° ALL SIDE SOLVENT SOCKET</p>	40	1 1/2"	YB1H3G
	50	2"	YB23G
 <p>REDUCER BUSH</p>	50 X 32	2" X 1 1/4"	RB21Q2G
	50 X 40	2" X 1 1/2"	RB21H2G
 <p>SOLVENT SOCKET END CAP</p>	50	2"	EC22G
	110	4"	EC42G
 <p>VENT COWL</p>	110	4"	VC43G



BUREAU VERITAS

Bureau Veritas Certification

QATAR PLASTIC ADDITIVES & INDUSTRIAL GROUP (QADDCO)

ISO 9001:2015

Scope of certification

Site Name/Location	Site Address	Site Scope
QATAR PLASTIC ADDITIVES & INDUSTRIAL GROUP (QADDCO)	GATE 150, STREET 48, INDUSTRIAL AREA, DOHA, P.O. BOX: 40290, STATE OF QATAR	TOP MANAGEMENT, PROCUREMENT, HR, ADMIN AND STORES PROCESSES.
QATAR PIPE LINE AND FITTINGS COMPANY (QPF)	GATE 150, STREET 48, INDUSTRIAL AREA, DOHA, P.O. BOX: 40290, STATE OF QATAR	PRODUCTION AND SUPPLY OF PLASTIC PIPES AND FITTINGS, TRADING OF PLASTIC PIPE FITTINGS AND RELATED ACCESSORIES.
QATAR PLASTIC ADDITIVES COMPANY (QAC)	BUILDING NO. 58, STREET NO. 22, ZONE 81, NEW INDUSTRIAL AREA, DOHA, P.O. BOX: 40290, STATE OF QATAR	SUPPLY ADDITIVES
QATAR PLASTIC COMPOUNDING COMPANY (QPC)	BUILDING NO. 110, STREET NO. 2, ZONE 81, NEW INDUSTRIAL AREA, DOHA, P.O. BOX: 40290, STATE OF QATAR	PRODUCT

Certificate No.: QA002932 Version: 1 Issue

[Signature]
K.P. - Certification Manager

Certification Body Address: 5th Floor, 66 Prescot Street, London, E1 8...
Local Office: Bureau Veritas International Doha W.L.L. G1-G3, Ground No. 230, Zone 261, C Ring Road, Opposite Gulf Times, P. O. Box: 22157...
Further clarifications regarding the scope and validity of this certificate, and the applicability of requirements, please call: +97440329729

Bureau Veritas Certification

QATAR PLASTIC ADDITIVES & INDUSTRIAL GROUP (QADDCO)

GATE 150, STREET 48, INDUSTRIAL AREA, DOHA, P.O. BOX: 40290, STATE OF QATAR

This is a multi-site certificate, additional sites are listed on the next page(s)

Bureau Veritas Certification Holding SAS - UK Branch certifies that the Management System of the above organisation has been audited and found to be in accordance with the requirements of the management system standards detailed below

ISO 9001:2015

Scope of certification

PRODUCTION, SUPPLY & TRADING OF PLASTIC ADDITIVES, MASTER BATCHES AND PREBLENDS, PRODUCTION AND SUPPLY OF PLASTIC PIPES AND FITTINGS, TRADING OF PLASTIC PIPE FITTINGS AND RELATED ACCESSORIES, PRODUCTION AND SUPPLY OF SOFT AND RIGID PVC COMPOUND.

Original cycle start date:	11-01-2016
Expiry date of previous cycle:	NA
Certification / Recertification Audit date:	NA
Certification / Recertification cycle start date:	10-01-2022
Subject to the continued satisfactory operation of the organization's Management System, this certificate expires on:	10-01-2025
Certificate No.:	QA002932
Version:	1
Issue Date:	10-01-2022

[Signature]
K.P. - Certification Manager

Certification Body Address: 5th Floor, 66 Prescot Street, London, E1 8HB, United Kingdom

Local Office: Bureau Veritas International Doha W.L.L. G1-G3, Ground Floor, KG Building (Bldg. No. 194, Street No. 230, Zone 261, C Ring Road, Opposite Gulf Times, P. O. Box: 22157, Doha, State of Qatar

Further clarifications regarding the scope and validity of this certificate, and the applicability of the management system requirements, please call: +97440329729



0008





Kitemark™ Certificate



This is to certify that:

Qatar Pipeline & Fittings Company
Building No. 150
Industrial Area Street No. 48
DOHA
40290
Qatar

Holds Certificate Number:

KM 539164

In respect of:

BS EN 1329-1
Plastic piping systems for soil and waste discharge (low and high temperature) within the building structure - unplasticized poly(vinyl chloride) (PVC-U)

This issues the right and licence to use the Kitemark in accordance with the Kitemark Terms and Conditions governing the use of the Kitemark, as may be updated from time to time by BSI Assurance UK Ltd (the "Conditions"). All defined terms in this Certificate shall have the same meaning as in the Conditions.
The use of the Kitemark is authorized in respect of the Product(s) detailed on this Certificate provided at or from the above address.

For and on behalf of BSI:

First Issued: 2010-08-02
Latest Issue: 2022-02-01



This certificate has been issued by and remains the property of BSI Assurance UK Ltd, Kitemark Court, Davy Avenue, Knowlhill, Milton Keynes MK5 8PP, United Kingdom and should be returned immediately upon request. To check its validity telephone +44 (0) 345 080 9000. An electronic certificate can be authenticated [online](#).
BSI Assurance UK Limited, registered in England under number 7805321 at 389 Chiswick High Road, London W4 4AL, UK.
A member of BSI Group of Companies.

Frank Lee, Product Certification Technical and Compliance Director

Effective Date: 2022-02-07
Expiry Date: 2025-02-06



Kitemark™ Certificate



This is to certify that:

Qatar Pipeline & Fittings Company
Building No. 150
Industrial Area Street No. 48
DOHA
40290
Qatar

Holds Certificate Number:

KM 539163

In respect of:

BS EN 1401-1
Plastics piping systems for non-pressure underground drainage and sewerage - Unplasticized poly(vinyl chloride)(PVC-U)

This issues the right and licence to use the Kitemark in accordance with the Kitemark Terms and Conditions governing the use of the Kitemark, as may be updated from time to time by BSI Assurance UK Ltd (the "Conditions"). All defined terms in this Certificate shall have the same meaning as in the Conditions.

The use of the Kitemark is authorized in respect of the Product(s) detailed on this Certificate provided at or from the above address.

For and on behalf of BSI:

First Issued: 2010-08-02
Latest Issue: 2022-05-10



This certificate has been issued by and remains the property of BSI Assurance UK Ltd, Kitemark Court, Davy Avenue, Knowlhill, Milton Keynes MK5 8PP, United Kingdom and should be returned immediately upon request. To check its validity telephone +44 (0) 345 080 9000. An electronic certificate can be authenticated [online](#).
BSI Assurance UK Limited, registered in England under number 7805321 at 389 Chiswick High Road, London W4 4AL, UK.
A member of BSI Group of Companies.

Frank Lee, Product Certification Technical and Compliance Director

Effective Date: 2022-05-10
Expiry Date: 2025-02-25

...making excellence a habit™

SD QATAR UNDERGROUND DRAINAGE SYSTEMS

BS EN 1401

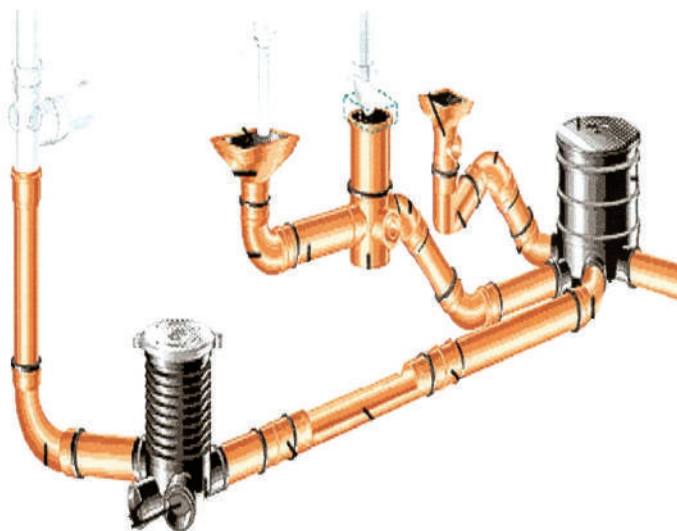

KITE MARKED BSI uPVC
UNDER GROUND DRAINAGE
PIPE & FITTINGS

UNDER GROUND DRAINAGE SYSTEMS

SD QATAR BS EN 1401 (Formerly BS 4660)

DESCRIPTION	MINIMUM WALL THICKNESS	SIZE		CODE
		mm	Inch	
 RUBBER SOCKET uPVC PIPE	3.2 mm	110	4"	PSD41B
	4.0 mm	160	6"	PSD61B
 DOUBLE SPIGOT uPVC PIPE	3.2 mm	82	3"	PSD34B
	3.2 mm	110	4"	PSD44B
	4.0 mm	160	6"	PSD64B
 STRAIGHT COUPLER SOLVENT SOCKET		82	3"	CO3B
		110	4"	CO4B
		160	6"	CO6B
 ELBOW 45° DOUBLE SIDE RUBBER SOCKET		82	3"	BD3B
		110	4"	BD4B
		160	6"	BD6B
 ELBOW 45° RUBBER SOCKET / SPIGOT				
		110	4"	BD41B
 FLOOR GULLY TRAP				
		110	4" X 3" X 2"	FGT432B
	110	4" X 3" X 1 1/2"	FGT43B	







UNDER GROUND DRAINAGE SYSTEMS

SD QATAR BS EN 1401 (Formerly BS 4660)

DESCRIPTION	SIZE		CODE
	mm	Inch	
 <p>ELBOW 90° DOUBLE SIDE RUBBER SOCKET</p>	82	3"	EL3B
	110	4"	EL4B
	160	6"	EL6B
 <p>ELBOW 90° RUBBER SOCKET / SPIGOT</p>	110	4"	EL41B
	160	6"	EL61B
 <p>ELBOW 90° DOUBLE SIDE RUBBER SOCKET WITH 3" ACCESS CAP</p>	110	4"	ELC4B
 <p>ELBOW 90° RUBBER SOCKET / SPIGOT WITH 3" ACCESS CAP</p>	110	4"	ELC41B
 <p>SHORT ELBOW 90° DOUBLE SIDE RUBBER SOCKET</p>	110	4"	SEL4B
 <p>EQUAL TEE 87.5° ALL SIDE RUBBER SOCKET</p>	82	3"	ET3B
	110	4"	ET4B
	160	6"	ET6B

UNDER GROUND DRAINAGE SYSTEMS

SD QATAR BS EN 1401 (Formerly BS 4660)

DESCRIPTION	SIZE		CODE
	mm	Inch	
 <p>EQUAL TEE 87.5° RUBBER SOCKET / SPIGOT</p>	110	4"	ET41B
	160	6"	ET61B
 <p>WYE BRANCH 45° ALL SIDE RUBBER SOCKET</p>	82	3"	YB3B
	110	4"	YB4B
	160	6"	YB6B
 <p>WYE BRANCH 45° RUBBER SOCKET / SPIGOT</p>	110	4"	YB41B
	160	6"	YB61B
 <p>REDUCED TEE 87.5° ALL SIDE RUBBER SOCKET</p>	160 X 110	6" X 4"	RT64B
 <p>REDUCED TEE 87.5° RUBBER SOCKET / SPIGOT</p>	160 X 110	6" X 4"	RT641B
 <p>REDUCED WYE BRANCH 45° ALL SIDE RUBBER SOCKET</p>	160 X 110	6" X 4"	RY64B



UNDER GROUND DRAINAGE SYSTEMS

SD QATAR BS EN 1401 (Formerly BS 4660)

DESCRIPTION	SIZE		CODE
	mm	Inch	
 <p>REDUCED WYE BRANCH 45° RUBBER SOCKET / SPIGOT</p>	160 X 110	6" X 4"	RY641B
 <p>ECCENTRIC REDUCER RUBBER SOCKET / SPIGOT</p>	110 X 82	4" X 3"	RE431B
	160 X 110	6" X 4"	RE641B
 <p>ECCENTRIC REDUCER ALL SIDE SPIGOT</p>	82 X 50	3" X 2"	RE322B
	110 X 50	4" X 2"	RE422B
	110 X 82	4" X 3"	RE432B
 <p>GULLY RAISING PIECE</p>	110 X 82 X 50	4" X 3" X 2"	GRP432B
 <p>REDUCER BUSH</p>	110 X 82	4" X 3"	RB432B
	160 X 110	6" X 4"	RB642B
 <p>P - TRAP GULLY RUBBER SOCKET</p>	110	4"	PTG4B

UNDER GROUND DRAINAGE SYSTEMS

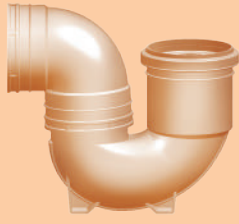
SD QATAR BS EN 1401 (Formerly BS 4660)

DESCRIPTION	SIZE		CODE
	mm	Inch	
 P - TRAP GULLY SOLVENT SOCKET	110	4"	PTG45B
 ACCESS CAP WITH PRESSURE PLUG	82	3"	ACP32B
	110	4"	ACP42B
	160	6"	ACP42B
 SOLVENT SOCKET END CAP	110	4"	EC42B

GRAVITY SEWERAGE uPVC PIPES

SD QATAR BS EN 1401 (Formerly BS 5481)

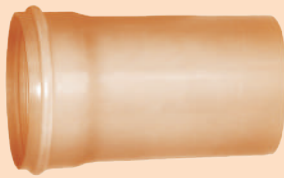
DESCRIPTION	MINIMUM WALL THICKNESS	SIZE		CODE
		mm	Inch	
 SOLVENT / SPIGOT uPVC PIPES	4.9 mm	200	8"	PSD84B
	6.1 mm	250	10"	PSD104B
	7.7 mm	315	12"	PSD124B
 RUBBER / SPIGOT uPVC PIPES	4.9 mm	200	8"	PSD81B
	6.1 mm	250	10"	PSD101B
	7.7 mm	315	12"	PSD121B

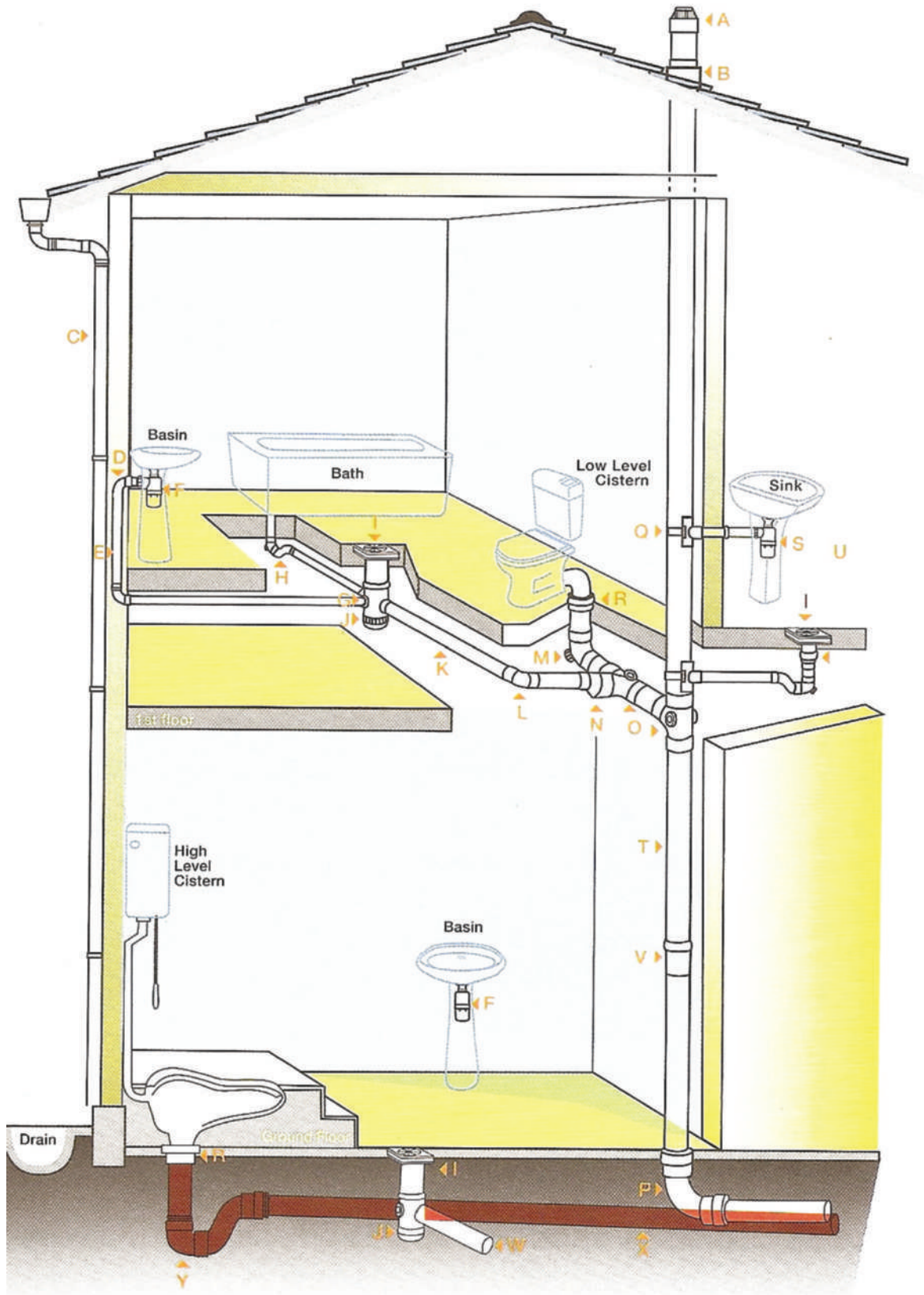

A 110mm VENT COWL • **B** 110mm WEATHER APORN • **C** 82mm PVC RAINWATER PIPE • **D** 32mm ELBOW 90° • **E** 32mm PVC PIPE • **F** 32mm BOTTLE TRAP • **G** 40x32mm REDUCER BUSH • **H** 50mm P TRAP • **I** 110x82mm GRATING W/ COLLER • **J** 110x82MM FLOOR GULLY TRAP • **K** 82mm PVC PIPE • **L** 82mm ELBOW 90° • **M** 110mm ELBOW 90° • **N** 110x82mm ECCENTRIC REDUCER • **O** 110mm EQUAL TEE • **P** 110mm UNDERGROUND ELBOW 90° • **Q** 110x40mm BOSS CONNECTOR • **R** 110mm WC PAN CONNECTOR • **S** 40mm BOTTLE TRAP • **T** 110mm PVC SOIL STACK • **U** 82x50mm CONCENTRIC REDUCER • **V** 110mm COUPLER RUBBERTYPE • **W** 82mm PVC PIPE • **X** 110mm UNDERGROUND PVC PIPE • **Y** 110mm P TRAP GULLY

ADVANTAGE OF USING SD QATAR PIPES & FITTINGS

Installation simplicity & flexibility:

Being a part of the British standard plastic pipes & fittings family it has been proven that our SD QATAR plastic pipes & fittings are simpler & have more flexibility to adapt to any installation design than other materials, even on the event of changing the system it is easy to dismantle & reused again for the similar installation.

Cost cutting:

As the major raw materials are all on the increase range it has been found that using SD QATAR plastic pipes & fittings will cost less than the half compare to any other materials for the same system. Also the easy installation causes also less installation cost.

Environmentally safety:

From the start as the raw materials of our pipes & fittings are Lead free & the raw materials are been handled with extra environmental awareness going to the process of manufacturing the pipes & the fittings until dispatch to the customer we have given the full attention to the environmental issue. Also our pipes have been approved to be the safest method of carrying liquids without any leaks or spills.

Availability & Timely Delivery:

Being in the gulf region it is very handy to find the product available & to find us for sharing the required information that can be needed for completing any design.

Highly resistant:

SD QATAR drainage systems are highly resistant to normal acids & alkali which makes it perfectly workable in wide range of industrial installations.

PROPERTIES OF THE PVC AT 20°C

PROPERTY	VALUE
Mechanical Specific Gravity Hardness Water Absorption Tensile Strength Elongation At Break Compressive Strength Modulus of Elasticity Izod Impact Strength Poisson's Ratio	1.42 120 Rockwell R 0.04-0.06 mg/cm ² >45 MPa > 80 % 66 MPa 2700 MPa 6 kJ/ m ² 0.35 - 0.4
Thermal Vicat Softening point Specific Heat Coefficient of Linear Expansion Thermal Conductivity Flame Resistance	82 °C 1047 J/Kg/°C 0.000007 mm/mm/°C 0.138 - 0.150 W/m/°C Self - Extinguishing
Electrical Volume Resistance Dielectric Constant @ 106Hz Dielectric Strength Dielectric Power Factor @106Hz	> 1X10 3.0 - 3.3 > 40 kV/mm 0.02

PVC Chemical Resistance chart

The excellent & high resistance of PVC-U for mainly the Acids & the Alkalis Makes the pipes & the fittings made by it very suitable for the industrial Applications. Below some of the chemicals that are commonly workable in the PVC drainage sewerage systems:

CHEMICAL	25°C	60°C	CHEMICAL	25°C	60°C	CHEMICAL	25°C	60°C	CHEMICAL	25°C	60°C
Acetic Acid	G	G	Acetic Acid 80%	G	M	Acetone	P	P	Alcohol	G	M
Alcohol 40%	G	M	Aluminum Chloride	G	G	Aluminum Fluoride	G	G	Aluminum Hydroxide	G	G
Aluminum Sulphate	G	G	Ammonia Gas (dry)	G	G	Ammonia 0.88S			Ammonium Chloride	G	G
Ammonium Carbonate	G	G	Ammonium Hydroxide	G	G	Ammonium nitrate	G	G	Ammonium Phosphate	G	G
Ammoniac	G	G	Ammonium Phosphate neutral	G	G	Aluminum Sulphate	G	G	Aniline Hydrochloride	P	P
Barium Carbonate	G	G	Barium Chloride	G	G	Barium Hydrochloride	G	G	Barium Sulphate	G	G
Beer	G	G	Brine	G	G	Benzene	P	P	Bleach	G	G
Beet Sugar Liquors	G	G	Chlorine gas (wet)	G	P	Calcium Carbonate	G	G	Calcium Chlorate	G	G
Carbon Dioxide	G	G	Castor Oil	G	G	Chloro-acetic acid	G	M	Chloric Acid 20%	G	G
Chlorine gas (dry)	G	M	Butanol	M	P	Chlorine water	G	G	Chlorine (liquid)	M	P
Chrome Slum Soln.	G	G	Chromic Acid 10%	G	G	Chrome Acid 30%	G	G	Disodium Phosphate	G	G
Cottonseed Oil	G	M	Cresylic Acid 50%	G	G	Cresylic Acid 100%	M	P	Crude Oil	G	G
Diesel Oil – Drev	G	G	Diesel Oil Gas	G	G	Detergents	G	G	Chrome Acid 50%	G	G
Hydrogen Sulphide	G	G	Hydrochloric Acid 80%	G	G	Hydrochloric Acid 50%	G	P	Hydrogen Peroxide 50%	G	G
Magnesium Hydroxide	G	G	Hydrochlorous Acid	G	G	Magnesium Carbonate	G	G	Magnesium Chloride	G	G
Ethylene Glycol	G	G	Mercuric Chloride	G	G	Mercury	G	G	Methyl Chloride	P	P
Milk	G	G	Mineral Water	G	M	Mixed Acid (dulute)	M	P	Molasses	G	G
Nickel Chloride	G	G	Nickel Nitrate	G	G	Nickel Sulphate	G	G	Nitric Acid 10%	G	M
Nitric Acid 66%	M	M	Nitric Acid 90%	P	P	Oils & Fats	G	G	Oleum	P	P
Animal Oil	G	G	Oxygen	P	P	Minerals	G	G	Vegetable	G	G
Petrol	P	P	Phosgene-gas	G	M	Phosphoric acid	G	G	Photograph Soln	G	G
Potassium Bromate	G	G	Tri-Sodium Phosphate	G	G	Potassium Dichromate	G	G	Sulphate Tri-Oxide Gas	G	G
Crude products	G	G	Silver Cyanide	G	G	Silver Nitrate	G	G	Sodium Chloride	G	G
Sodium Carbonate	G	G	Sodium Hydroxide	G	G	Sodium Dichromate	G	G	Spirits	G	G
Sulphuric Acid 10%-75%	G	G	Sulphurous Dioxide wet	G	M	Sulphur Dioxide Dry	G	G	Sulphuric Acid 75%-90%	G	G
Sodium Nitrate	G	G	Sulphurous Acid	G	G	Sulphuric Acid 90%	M	P	Plating solution	G	G
Potassium chloride	G	G	Urine	G	G	Vinegar	G	G	Acid water	G	G
Salty Water	G	G	White Liquor	G	G	Fresh Water	G	G	Xylene	P	P
Wetting Agents Diluted	G	G	Zinc Chloride	G	G	Zinc Sulphate	G	G	Zinc Nitrate	G	G

G = GOOD, M = MILD CHANGE, P = POOR

Thermal expansion & contraction

PVC coefficient linear expansion is 0.000007 mm/mm/°C, which means that in ten meters pipe it will expand 7 mm in each 10°C rise of temperature. However due to the short duration of most effluent flows & the slow temperature response of the material, the greatest thermal movement will take place due to variation in environment temperature rather than the effect of hot effluent discharge. Effective accommodation of thermal movement is dependent on the controlled direction & distribution of this movement.

If thermal can not be accommodated by different means, expansion joints should be employed with maximum spacing intervals for locating expansion joints are 6 meters for cold & 4 meters for hot pipe systems. The maximum length of pipeline between fixed points should be 2 meters for cold pipeline & 1 meter for hot pipeline.

For vertical soil & waste systems pipes must have expansion joints located on each floor where fixtures & branch lines are connected, directly above the highest branch connection. It must be also located at the end of the drain connection for a discharge pipe if the length of the pipe between fixed points exceeds the distance stated above.

As for graded pipelines expansion joints must be placed immediately upstream of the entry to a vertical stack or other graded line & upstream of each change of direction in the graded lines.

Pipe Support

It is important to install a support on the pipe at a fixed point to restrain all movements of the system. The clip or the support must be firmly fixed to the fitting located in the clamping groove where ever is provided. Or a sliding support or clip is to provide a guide without restrain on axial movement of the pipe.

Nominal Pipe Diameter (mm)	Horizontal Support (meter)	Vertical Support (meter)
32	0.50	1.20
40	0.50	1.20
50	0.60	1.20
82	1.00	2.00
110	1.00	2.00
160	1.20	2.00

Proper handling of SD QATAR pipes

Pipes can be stacked on the ground provided this surface is level and free from loose stones or any sharp objects. Socketed pipes must be stacked in layers with the socket placed at alternative ends of the rack, and protruding to avoid uneven stacks and distortion (the sockets must load free).

Racks for long term storage are recommended and must have continuous support at least 75 mm width & 1 meter apart. Also slide restrains must be placed at the centers not exceeding 1.5 meter & stacks should not exceed 10 pipes in height.



Pipe line design

1. Hydraulic Design

The capacity of flow in a pipeline can vary due to various factors, which include the roughness of pipe bore, influenced by the growth of slime, roughening due to abrasion and joint imperfections/fitting types and configurations.

Flow capacity is calculated by using the Colebrook White Transition Equation and it is assumed pipes are flowing full. This equation takes into account, liquid viscosity and pipe roughness, and is recognized as being one of the most accurate in general use but requires an iterative solution. This equation also enables user to establish the relationship between friction loss, discharge and velocity

$$v = -2 - \sqrt{2gd_1 J} - \log_{10} \left(\frac{2.51 - \mu}{d_1 - \sqrt{2gd_1 J}} + \frac{k}{3.71 - d_1} \right)$$

v = velocity of flow cross section (m/s)

g = gravity constant (9.81 m/s²)

d_i = pipe internal diameter (m)

J = gradient

k = hydraulic effective pipe roughness (m),

taking into consideration of: misaligned joints, diametrical deformation, change of direction and side inlets recommended figure is $k = 2.5 \times 10^{-4} m$

μ = kinematics viscosity of fluid ($1.31 \times 10^{-6} m/s^2$)

If filling degree is less than 100%, the internal pipe diameter d_i , is replaced with the hydraulic diameter, dh in the above equation. The relationship of the two parameters is defined as:

$$d_i = dh = 4A/U$$

$$a = \frac{d_i^2}{8} \left\{ \frac{\pi - 2 \operatorname{arccos}(1-2h/d_i)}{180^\circ} - \sin [2 \operatorname{arccos}(1-2h/d_i)] \right\}$$

$$U = \frac{d_i}{2} \left[\frac{2 \operatorname{arccos}(1-2h/d_i)}{180^\circ} \right]$$

And h/d_i as defined in diagram below;

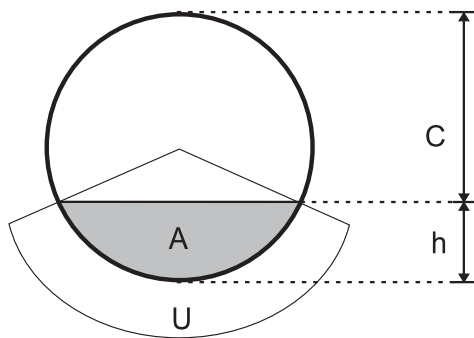

The flow capacity is determined by the following equations:

$$Q = v \times \{ \pi d_i / 4 \} \text{ for full bore flow and;}$$

$$Q = v \times A \text{ for partial bore flow}$$

2. Structural Design

Paling range of PVC pipes are classified as “flexible” pipes, which means they have the ability to deform or deflect diametrically within specified limits without structural damage or impairing the performance of the pipes.

The external soil and live loadings imposed on flexible pipes may cause a decrease in the vertical diameter and an increase in the horizontal diameter of the pipe. The horizontal movement of the pipe walls in the soil material at the sides develops a passive resistance within the soil to support the external load. Hence, the pipeline performance is influenced by the soil type and density. The higher the effective soil modules at pipe depth, the less the pipe will deflect.

A complete design approach is covered in BS EN 1295-1.

Related Standards (European & British Standards)

- BS EN 1329:2000** : PVC plastic piping system for soil & waste discharge within the building structure (high & low temperature flow).
- BS EN 1401:1999 & BS 4660** : PVC plastic piping system for non-pressure underground drainage & sewerage.
- BS 4514 :1983** : PVC soil & ventilating pipes, fittings & accessories specification.
- BS 5255:1989** : Specification for thermoplastics waste pipe & fittings.
- BS EN 1455-1:2000** : ABS plastic piping systems for soil & waste (low & high Temp.) within building structure.
- BS 3943:1979** : plastic waste traps specifications.
- BS 6209:1982** : solvent cement for non-pressure thermoplastics pipe systems specification.
- BS EN 681-1:1996** : Rubber material specification requirements for pipe joint seals used in water & drainage application.
- BS EN 124:1994** : Manhole covers & frames.
- BS EN 752: Parts 1-7:1997** : Drain & Sewer system outside buildings.
- BS EN 1295-1:1998** : structural design of buried pipelines under various condition of loading general requirements.
- BS EN ISO 9001-2:2000** : Quality Management System.

Installation methods of SD QATAR pipes & fittings

A. Solvent cement jointing:



Remove all burrs & chamfer the external pipe edge



Remove all dust made by the Chamfering & any trace of grease inside & outside the edge of the pipe with dry & clean cloth



mark the spigot with the same depth of the socket prior to applying the solvent cement



Apply equal quantity of solvent cement to the spigot (not to exceed the marked line) & the socket



Push the spigot & the socket together while the solvent cement is wet & hold for at least for 30 seconds to allow the dryness of the solvent cement

B. Rubber Ring Jointing:



Clean the socket from any dirt or grease specially the inside the ring groove



Fold the rubber ring as shown preparing it to the socket



Insert the rubber ring as shown in the socket of the pipe



Make sure that the rubber ring is firmly in the socket with no edges out of the ring groove



Chamfer the spigot side of the pipe before sliding it to the rubber socket in the pipe or the fitting



Mark the depth of the socket on the spigot



Push firmly the socket & the spigot to each other until the marked socket depth line is covered

Installation of underground Piping System (Trenching):

Trenching of the pipes is preferred to be done with accordance to the British Standard BS 5955 Part 6 (installation of PVC-u pipe work for gravity drains and sewers).

It's essential that the sides of the trench are well supported during the laying of the pipes, trench width should be narrow but in a way that it will not be less than the pipe diameter plus 300mm – 360mm added to allow adequate side fill to be placed.

Trenches when excavated are either 'stable' or 'unstable'. The category into which a trench fits is affected by the soil conditions, width, depth and method of excavation. To ensure that maximum support is given to the buried pipe by the undisturbed ground the resultant stable or unstable trench should be treated in the following way:

1- Stable conditions

Stable conditions are those where, after excavation, the trench walls remain solid and do not show any signs of collapse or cave-in. Under such conditions the recommended trench widths are shown in the following table:

Pipe Diameter (mm)	Normal Width (mm)
100	400
150 - 200	600
225 - 300	750
375	900

2- Unstable conditions

Unstable conditions are those where, during or after

excavation, the trench walls tend to collapse and cave-in. Under these conditions, in open or unrestricted areas, the top of the trench can be widened until stability is reached. A smaller trench should then be dug in the bottom of the excavation to contain the pipe as shown. In areas where space is limited, e.g. in streets, it may be necessary to support trench walls by timber or other suitable shoring.

Trench depths

The minimum trench depth should be such that pressures created by the weight of fill material plus anticipated traffic or other superimposed loads will not damage the pipes. As a guide the recommended minimum clear cover above is listed below:

- . Where no subject to vehicular loading: 300mm
- . Where subject to vehicular loading:
 - . Under driveways: 450mm
 - . In sealed roadways: 600mm
 - . In unsealed roadways: 750mm

Trench Laying & Compaction Steps:

1. Preparing the trench

The trench bottom should be as level as possible, so that the barrel of the pipe is fully supported along its whole length. In good working conditions, sandy or loamy soil, the trench bottom can be made sufficiently even with stones and rocks removed to provide continuous support for the pipes without the need of under-bedding.

2. Wet conditions

In wet ground, sloppy working conditions can be alleviated by first placing a layer of hard granular material, or by de-watering the area in and around the trench. If patches of ground are so wet that there is a risk of subsidence and possible damage to sections of the pipeline, these areas should be consolidated by the addition of suitable fill material.

3. Trench installation

The trench should be excavated deeply enough to allow for the specified grade, the required depth of bedding, and the minimum cover over the pipe.

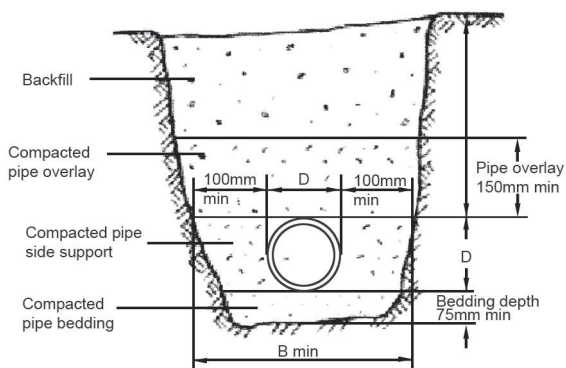

The following materials are suitable for bedding and overlay in the trench:

- Suitable sand, free from rock or other hard or sharp objects.
- Crushed rock or gravel of approved grading up to a maximum size of 14mm
- The excavated material, if it is free from rock or hard matter and broken up so that it contains no soil lumps having any dimension greater than 75mm which would prevent adequate compaction of the bedding.
- Cement mortar, containing one part of cement and four parts of sand by volume, mixed with clean water to a workable consistency (bedding only).

4. Bedding & Backfill

When the trench is fully ready to lay the pipe, we have to make sure that the bottom of the pipe is trimmed to be the bed of the pipe & the as-dug soil is used as the side fill of that pipe with accordance to BS EN 1610 bedding construction type 3. Suitable material is defined as the sidefill with maximum particle size not exceeding 20mm. Refer to the drawings for more details.

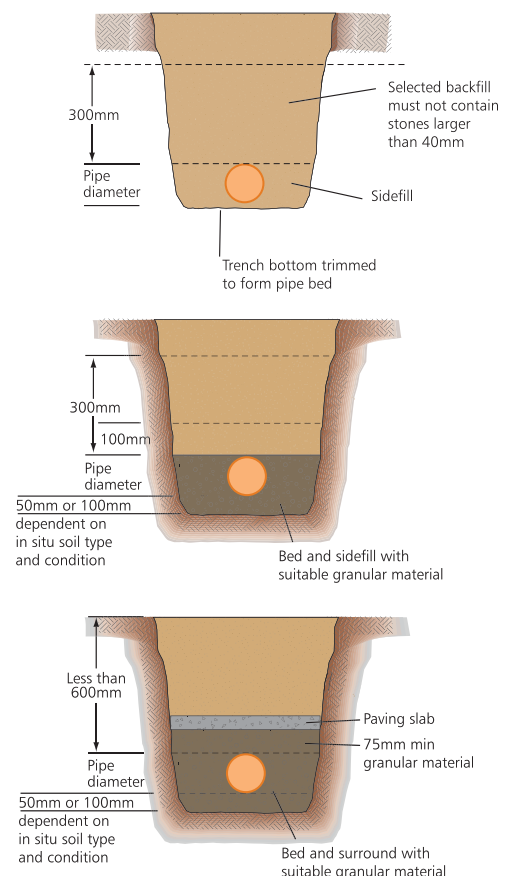

Once the pipe is laid in the trench backfilling can commence. Two distinct phases are involved with pipelines:

- backfilling prior to testing the pipeline
- backfilling after testing the pipeline

Backfilling usually follows pipe installation as closely as possible in order to protect the pipe from external damage, to eliminate the possibility of the pipe floating due to flooding of open trenches, and to avoid shifting the pipe out of line due to cave-in.

It should be remembered that the purpose of backfilling is not only to protect the pipe by covering it, but to provide firm continuous support under the pipe. Where concrete or mortar bedding has been used, however, the bedding must have obtained its required strength prior to backfilling.

Testing SD QATAR pipelines:

Testing is done in accordance to the two systems Soil & Waste system & the underground system as follows:

A. Testing SWV Pipelines

Two types of testing are in current use - hydrostatic testing and air testing. The choice of the type of test, its duration and test pressures required depend on the requirements of the authority concerned. All solvent cement work should be allowed to cure for at least 24 hours from the time of the last joint made. All joints must be checked during the test. In the event of leakage, pipe work must be repaired and retested.

1. Hydrostatic testing:

Otherwise specified by the relevant authority, pipe work should be tested at the static head of not exceeding 6m and maintained for a period of 24 hours.

2. Air testing:

Air should be gradually introduced by a suitable means until a pressure of not exceeding 50 kPa is obtained. The pressure is maintained for at least 3 minutes.

B. Testing Underground pipelines

Modern construction practice is to adopt some rigorous

form of acceptance test on newly constructed sewer lines. It is usual for two separate tests to be made: one prior to backfilling and another towards the end of the job when backfilling has been completed and settled, and manholes and sidelines constructed.

The purpose of testing a non-pressure pipeline is to ensure that the line has been correctly laid to line and grade, will flow satisfactorily and is sealed at each joint and fitting.

In the case of a sewer pipeline system, three distinct areas require testing.

1. The sewer rising mains
2. The gravity pipeline sections
3. The gravity reticulation sections

The first is a pressure pipeline and should be tested accordingly. The later two require testing for which recommended practices are as follows:

A. Preparing for the test

During the installation careful checking and adequate supervision will ensure that sewer lines are laid to line and grade. If an installation specification exists it should be followed. Otherwise the pipeline section to be tested should be backfilled leaving all couplings and fittings exposed for inspection during testing. In solvent weld PVC-U jointed non-pressure pipelines, at least 24 hours should have elapsed since the last joint was made before testing commences.

B. Test procedures

Two types of testing are in current use - hydrostatic testing and air testing. The choice of the type of test, its duration and test pressures required depend on

the requirements of the authority concerned and may also be governed by the availability of water on the site, but in general hydrostatic testing is recommended.

1. Hydrostatic testing

The single opening at the top of the test section should be fitted with a special test plug. The test plug should have two entries; an upper one connected to a calibrated container capable of supplying makeup water when filled, and a lower entry connected to a water supply.

The pipeline should be filled with water allowing air to escape through the upper entry in the test plug via the calibrated container.

Unless otherwise specified by the client or relevant Government Authority, the following figures are recommended.

When pipeline is full, using the calibrated container raise the pipeline pressure to between 2m and 3m above the natural surface at the top of the test section. Allow the pipeline time to settle during which period make-up water should be added. This period should be a minimum of 24 hours.

During a subsequent one hour test the water loss measured by the drop in water level should not exceed 0.55 liters per 10mm internal diameter per 100 meters of pipe length. During the test all joints should be inspected.

Should the pipeline fail to pass the test it must be further examined to locate the leak, then drained, repaired and retested.

a) Volume of water required to fill the pipeline

The following table guides as to how much water is required to fill up the test section of pipeline.

However, slight variation from the tabulated figure

should be expected due to change in pressure and temperature.

Size (mm)	Volume, liter/meter
110	8.4
160	18.1
250	44.4
315	70.5

b) Make-up water

Make-up water will generally be necessary to obtain a satisfactory test, because of entrapped and entrained air etc., even if the pipeline is laid with the best of care under favorable conditions.

2. Low pressure air testing

The methods and test procedures outlined in any installation specification should be followed. If no such specification exists the following test procedures of AS2032 are recommended for air testing of a sewer pipeline section.

The pipeline should be sealed in the manner described for hydrostatic testing, but incorporating an air pressure gauge. Air should be introduced slowly by a suitable means until a pressure of 50 kPa is obtained.

The pressure should then be maintained for a period of at least 3 minutes. Should no leaks be apparent at the end of 3 minutes, the air supply should be shut off and provided the air contained in the pipes under test does not fall below 35 kPa within 50 seconds, the pipeline may be considered satisfactory.

If however, the pressure is not maintained within these specified limits, the air should be reintroduced and the pipeline examined for leaks using a concentrated solution of soft soap and water over the joints and fittings. When the source of the leak has been detected and repaired the pipeline should be retested.



CERTIFICATE

This is to Certify that

Environmental Management System

of

QATAR PIPE LINE AND FITTINGS COMPANY (QPF)

Building No. 150, Street 48, Industrial Area Po Box 40290 Doha Qatar

has been independently assessed by DBS
and is comply with the requirement of:

ISO 14001:2015

For the following scope of activities:

*Production and Supply of Plastic Pipes and Fittings, Trading of Plastic Pipes,
Fittings and Related Accessories.*

Certificate Number: E-205022012005

Date of Certification:	20th January 2022
1st Surveillance Audit Due:	19th January 2023- Done
2nd Surveillance Audit Due:	19th January 2024- Not Done
Certificate Expiry:	19th January 2025
Re-Certificate Due:	19th January 2025

This Certificate is property of DBS Certifications and remains valid
subject to satisfactory surveillance audits

Head of Certification



The certificate remains the property of DBS Certifications Private Limited, to whom it must be returned upon request.

DBS CERTIFICATIONS PVT. LTD.

142, 11nd Floor, Avtar Enclave, Paschim Vihar, Delhi-110063, (INDIA) info@dbscertification.com, www.dbscertification.com

ACCREDITED BY :

International Accreditation Service (IAS) 3060, Saturn Street Suite 100, Brea, Ca 92821-1732, United States of America
Qatar Office Address: www.iqs.com.qa Tel: 44981968/66188236 Email: info@iqs.com.qa



CERTIFICATE

This is to Certify that

Occupational Health and Safety Management System

of

QATAR PIPE LINE AND FITTINGS COMPANY (QPF)

Building No. 150, Street 48, Industrial Area Po Box 40290 Doha Qatar

has been independently assessed by DBS
and is comply with the requirement of:

ISO 45001:2018

For the following scope of activities:

*Production and Supply of Plastic Pipes and Fittings, Trading of Plastic Pipes,
Fittings and Related Accessories.*

Certificate Number: HS-205022012006

Date of Certification:	20th January 2022
1st Surveillance Audit Due:	19th January 2023- Done
2nd Surveillance Audit Due:	19th January 2024- Not Done
Certificate Expiry:	19th January 2025
Re-Certificate Due:	19th January 2025

This Certificate is property of DBS Certifications and remains valid
subject to satisfactory surveillance audits

Head of Certification



The certificate remains the property of DBS Certifications Private Limited, to whom it must be returned upon request.

DBS CERTIFICATIONS PVT. LTD.

142, 11nd Floor, Avtar Enclave, Paschim Vihar, Delhi-110063, (INDIA) info@dbscertification.com, www.dbscertification.com

ACCREDITED BY :

International Accreditation Service (IAS) 3060, Saturn Street Suite 100, Brea, Ca 92821-1732, United States of America
Qatar Office Address: www.iqs.com.qa Tel: 44981968/66188236 Email: info@iqs.com.qa

و حال الحصول على موافقة الهيئة الرسمية، تقع المسؤولية على عاتق الوكيل المحلي لتوريد المواد المعتمدة من قبل الاستشاري المكلف بالإشراف على المشروع، ويتم ذلك من خلال تقديم المستندات الاعتمادية اللازمة لمواد المشروع للمراجعة والتأكد من استيفاء كافة متطلبات هيئة الأشغال العامة والامتثال إلى أحدث إصدار من "مواصفات قطر للإنشاء" (QCS) بالإضافة للمتطلبات التي يتم تحديدها بحسب طبيعة المشاريع الجاري تنفيذها.

After gaining approval, it is the Local Agent's responsibility to get the material approved from project Supervision Consultants through a project material submittal that ensures full compliance with the PWA requirements and the latest version of Qatar Construction Specifications (QCS) as well as the relevant project specific requirements of that project.

This approval shall not be interpreted as a guarantee for providing materials or services for any ASHGHAL projects and the Authority shall not be held responsible nor accept any liability for Manufacturer / Supplier / Subcontractor losses, expenses, damages to reputation or any other damages whatsoever arising out of or in relation to taking part in the authority prequalification procedure.

Yours sincerely,

إضافة لما سبق، فلا يجوز تفسير ما ورد أعلاه كموافقة عامة لأي مشروع من مشاريع الهيئة. بلية جراه أي خسائر أو نفقات صنعة/ الموزد/ المقاول من لحقت بسمعة الشركة أو أي مشاركة في إجراءات الاعتماد

25/09/2023 12:39:43 PM
2023/0024575/5

Mr. Hassan Al Hour
Vice Chief Executive Officer
Qatar Pipeline & Fittings Company
PO Box: 40290- Doha, Qatar
Fax: +974 44603993

السيد/ حسن الهور
نائب الرئيس التنفيذي
شركة قطر للأنابيب والوصلات
صندوق بريد: 40290- الدوحة، قطر
فاكس: +974 44603993

Dear Sir,

تحية طيبة وبعد،،،

Subject: Renewal Approval of uPVC Pipe and Fittings as Manufactured by Messrs. QADDCO /SD Qatar in their Factory in Qatar to be used for Buildings Projects

الموضوع: تجديد الموافقة على إدراج uPVC Pipe and Fittings من إنتاج شركة QADDCO /SD Qatar في مصنعهم القائم بدولة قطر لاستخدام في مشاريع المباني في أشغال

The Vendors Prequalification Committee (VPC) refers to the application submitted with PWA Ref: 2023/0043446/1, and your request to renew the approval for Messrs. QADDCO /SD Qatar as an approved manufacturer for uPVC Pipe and Fittings as it appears on the Approved list for Buildings: (Approved Material List) (ashghal.gov.qa).

بالإشارة إلى الطلب المقدم بموجب كتاب اشغال مرجع رقم 2023/0043446/1 لتجديد الموافقة على إدراج السادة (QADDCO /SD Qatar) ضمن قائمة مُصنّعين المواد المعتمدين لدى الهيئة ضمن الفئة (uPVC Pipe and Fittings) ، حسب قائمة الموزدين المعتمدين لمشاريع المباني التابعة للهيئة Approved Material List (ashghal.gov.qa).

Following our general evaluation process, the Committee has decided to approve the renewal. This renewal approval is valid for a period of three (3) years from the date of this letter, and it will be subject to the Authority's review at any time throughout this period. It is the Vendor's responsibility to apply for the renewal three (3) months prior to the expiry date, otherwise the listing shall be removed from the authority's vendor list.

نحيطكم علماً أنه وعقب إجراءات التقييم المعتمدة والمتبعة لدينا، فقد قررت لجنة تأهيل الشركات المنتجة والموزدة للمواد ومقاولي الباطن الموافقة على طلب التجديد المعني. علماً بأن صلاحية هذه الموافقة سارية لـ (3) سنوات فقط من تاريخه، مع احتفاظ الهيئة بحق المراجعة وإعادة النظر في أي وقتٍ خلال هذه الفترة. وتقع المسؤولية على عاتق الموزد/ المصنّع لتقديم طلب رسمي لتمديد صلاحية الموافقة قبل تاريخ انتهائها بـ (3) أشهر وإلا فسيتم إلغاء الشركة من قائمة الموزدين المعتمدين.

The quality and performance of Messrs. QADDCO /SD Qatar, as an Approved Manufacturer shall be closely monitored by the Authority at all times to ensure that the required standards are met. If it is found by the Authority at any time that the quality and performance is failing to meet the expected standards, then the committee reserves the right to withdraw their Approval.

ويرجى العلم بأنه سيتم رصد ومراقبة جودة أداء QADDCO /SD Qatar من قبل الفريق المختص بالهيئة في جميع الأوقات لضمان الامتثال إلى كافة المعايير القياسية والقواعد الإرشادية. كما أن للهيئة الحق في سحب الموافقة أو إلغائها في حال انضح وجود أي تقصير في أداء الشركة المصنّعة أو أي تخاذل في استيفاء المعايير المعتمدة والمعمول بها.





Qatar Pipeline & Fittings Co.

Tel.: +974 - 4450 6517, Fax: +974 - 4460 3993, P. O. Box: 40290 Doha - Qatar

e-mail: enquiry@qaddcoqatar.com

www.qaddcoqatar.com

