

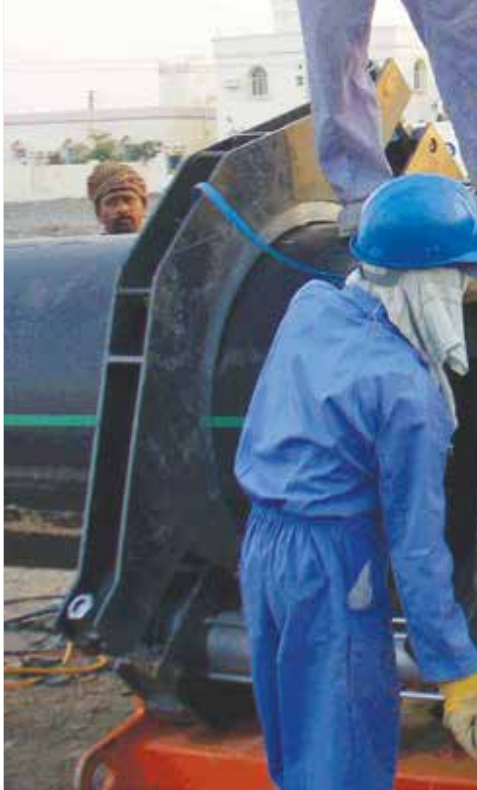

شركة الصناعات الوطنية
NATIONAL INDUSTRIES COMPANY
Since 1960 مؤسسة
www.nicbm.com 1 844 555

HDPE



**PRESSURE PIPING SYSTEM
DRAINAGE & SEWERAGE PIPING
CABLE DUCT & SUB DUCT**

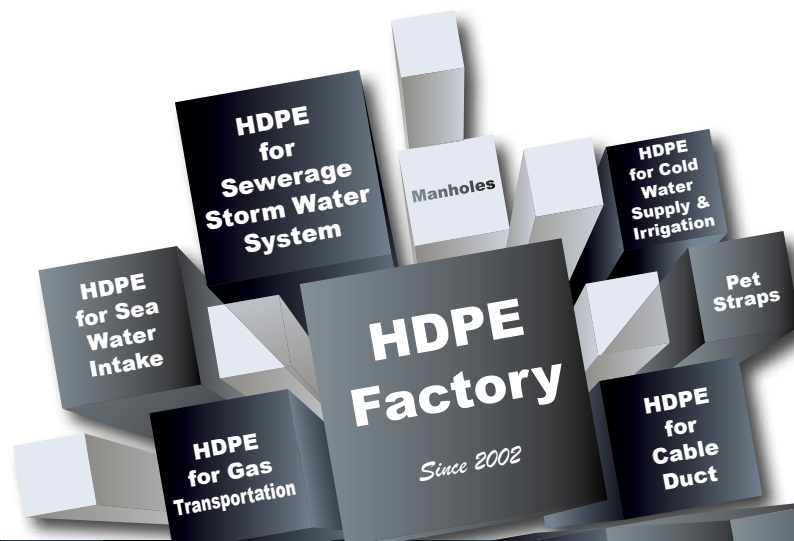

NIC Products



Interlock &
Yard Tiles



Limestone



Plastics



LED Lights



Dry Mortar



Cement
Cladding
Bricks



Ready Mix



Ceramics



White
Blocks



Benches &
Flower
Pots



Paints



Cladding



Concrete
Pipes



HDPE



NI Panels

HDPE

PRESSURE PIPING SYSTEM

HDPE pipes have been used extensively for drinking water distribution throughout Europe for over 40 years and have proven to be safe and reliable for this application. PE pipe is generally resistant to the chemicals commonly used for water treatment and disinfection. HDPE PE 100 is an exciting material, being used for the manufacture of “NIC HDPE” pipes suitable for following applications.

1. Civil engineering: Used for portable water, normal water supply, drainage pipeline, natural gas, heating and cooling system pipe lines, closed loop refrigeration and house cooling system, sewerage treatment plants, subsoil drainage pipes, firewater mains, house connection and plumbing.
2. Oil field: Used for crude collecting, sewage disposal, crude transportation, finished petroleum conveyance, transportation of polymer solution to wells etc. It is especially suitable for transportation of mediums of oil, gas, and water with high sulfur content. Also best suitable for sea water intake pipes.
3. Chemical industry: Applicable to acid, alkali & salt manufacture, petrochemical industry, chemical fertilizer production, pesticide production & pharmacy, etc for process tubing & drainage pipelines to convey corrosive mediums.
4. Ship building: Used for living pipeline system, structural & waste water pipeline.
5. Coal mines: Used for transportation of coal-water slurries, coal bed gas & ash, etc.
6. Electrical engineering: Fiber optic cable ducts, inner ducts, electrical conduits, etc.
7. Agriculture: Water supply and drainage pipes, Drip irrigation system, Bore well liners.
8. Others: metallurgical industry, food industry, compressed air pipes, etc.

TECHNICAL DATA OF PE (100)

No	Description	Value	Unit	Standard
1	Minimum Required MRS	10.0	N/mm ²	PE 100
2	Density (black compound) (ρ)	940 - 960	kg/m ³	ISO1183 , ISO 1872-2B
3	Melt Flow Rate(MFR) (190 °C, 2.16 kg)	< 0.15	g/10min	ISO 1133
4	Tensile Strength at yield (50mm/min)	≥ 21	MPa	ISO 527 -2
5	Elongation at break (ϵ)	> 350	%	ISO 527 -2
6	Charpy impact strength, notched	16	kJ/m ²	ISO 179/1eA
7	Hardness by shore D	≥ 60	Share D	ISO 868
8	Carbon Black Content	≥ 2 %	%	ASTM D 1603
9	Modulus of Elasticity	≥ 800	MPa	ISO 527
10	Thermal Stability @ 200 °C	≥ 20	Minutes	EN 728
11	Resistance to liquid chemicals	112	Days	ISO 4433
12	ESCR (Environment Stress Crack Resistance)	≥ 10000	hours	ASTM 1693
13	Resistance to rapid crack propagation	Crack arrest	-	ISO 13477
14	Expansion coefficient (α)	1.75×10^{-4}	K ⁻¹	BS 6431 part15

- Service life of more than 100 years.
- Superior resistance to most of chemicals and acids.
- Virtually non degradable with living organism.
- Most suitable material to use with sea water.
- Smooth inner surface offers least friction compared to other pipes.
- 100% leak proof joints with butt welding of pipes & fittings.
- Can be recycled 100%.
- Economical and easy to install due to light weight.
- Can be produced in longer lengths reducing joints and cost of installation.
- Due to resistance against crack propagation HDPE pipes are suitable for Natural Gas.

APPLICABLE STANDARDS:

Standard	Title
DIN 8074 & 8075	Dimensions and quality requirement.
ISO 4427	Polyethylene pipes for water supply
ISO 4437	Buried Polyethylene pipes for the supply of gaseous fuels.
EN 1519	Polyethylene pipes for soil and waste discharge within the building structure.
ASTM D 570	Standard Test Method for Water Absorption of Plastics
ASTM D 638	Standard Test Method for Tensile Properties of Plastics
DIN 16874	Polyethylene pipes and fittings for cable ducting.
BS EN ISO 9001	Quality standard for manufacturing.
ASTM F714	Polyethylene pipes based on outside diameter.

“NIC HDPE” Pipes made from (PE 100) as per ISO 4427 DIN 8074 / 8075

Nominal Pressure at 20 °C	PN 4	PN 6*	PN 6.3	PN 10	PN 12.5	PN 16	PN 20	PN 25
SDR	SDR 41	SDR 27.6	SDR 26	SDR 17	SDR 13.6	SDR 11	SDR 9	SDR 7.4
DN (Outer dia) mm	Thickness mm	Thickness mm	Thickness mm	Thickness mm	Thickness mm	Thickness mm	Thickness mm	Thickness mm
20						2.0	2.3	3.0
25					2.0	2.3	3.0	3.5
32				2.0	2.4	3.0	3.6	4.4
40			1.8	2.4	3.0	3.7	4.5	5.5
50		1.8	2.0	3.0	3.7	4.6	5.6	6.9
63		2.4	2.5	3.8	4.7	5.8	7.1	8.6
75	1.9	2.7	2.9	4.5	5.6	6.8	8.4	10.3
90	2.2	3.3	3.5	5.4	6.7	8.2	10.1	12.3
110	2.7	4.0	4.2	6.6	8.1	10.0	12.3	15.1
125	3.1	4.5	4.8	7.4	9.2	11.4	14.0	17.1
160	4.0	5.8	6.2	9.5	11.8	14.6	17.9	21.9
200	4.9	7.2	7.7	11.9	14.7	18.2	22.4	27.4
225	5.5	8.2	8.6	13.4	16.6	20.5	25.2	30.8
250	6.2	9.1	9.6	14.8	18.4	22.7	27.9	34.2
315	7.7	11.4	12.1	18.7	23.2	28.6	35.2	43.1
355	8.7	12.9	13.6	21.1	26.1	32.2	39.7	48.5
400	9.8	14.5	15.3	23.7	29.4	36.3	44.7	54.7
450	11.0	16.3	17.2	26.7	33.1	40.9	50.3	61.5
500	12.3	18.1	19.1	29.7	36.8	45.4	55.8	68.3
560	13.7	20.3	21.4	33.2	41.2	50.8	62.5	
630	15.4	22.8	24.1	37.4	46.3	57.2		
710	17.4	25.7	27.2	42.1	52.2	64.5		
800	19.6	29.0	30.6	47.4	58.8	72.7*		
900	22.0	32.6	34.4	53.3	66.1	81.8*		

* Special sizes by National Industries Company.

Allowable working pressure bars (AS per DIN 8074:2011)

Temp °C	Service Life Years	PN 4	PN 6 *	PN 6.3	PN 10	PN 12.5	PN 16	PN 20	PN 25
		SDR 41	SDR 27.6	SDR 26	SDR 17	SDR 13.6	SDR 11	SDR 9	SDR 7.4
Allowable working pressure bars									
20	50	4.0	6.0	6.3	10.0	12.5	16.0	20.0	25.0
	100	3.9	5.8	6.1	9.8	12.3	15.5	19.5	24.6
30	25	3.4	5.1	5.4	8.6	10.9	13.7	17.3	21.8
	50	3.4	5.0	5.4	8.5	10.7	13.5	17.0	21.5
40	25	2.9	4.4	4.6	7.4	9.3	11.7	14.8	18.6
	50	2.9	4.3	4.6	7.3	9.1	11.5	14.5	18.3
50	10	2.6	3.8	4.1	6.5	8.2	10.3	13.0	16.4
	15	2.6	3.8	4.1	6.5	8.2	10.3	13.0	16.4
60	5	2.3	3.3	3.6	5.7	7.2	9.1	11.5	14.5
70	2	2.1	3.0	3.3	5.2	6.6	8.3	10.5	13.2

* Special Sizes by NIC

BUTT WELDING

“NIC HDPE” pipes are joined by Butt Welding. Butt welding of polyethylene pipe is just a matter of melting the ends of two piping components together. If required, NIC provides equipment and technical assistance for joining of pipes.

Equipment for butt welding requires electrical power. Butt welding gives a high tensile leak proof homogeneous joint.

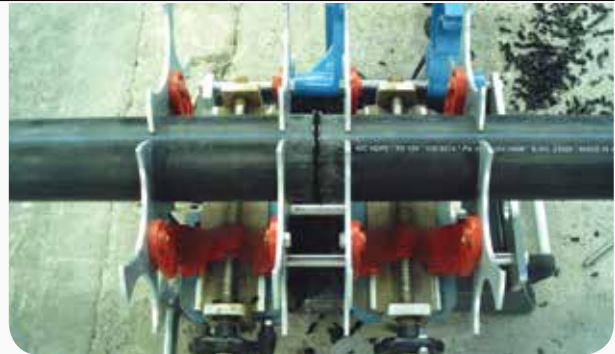

Butt Welding



Hydrostatic Pressure Testing



Moulded Fittings

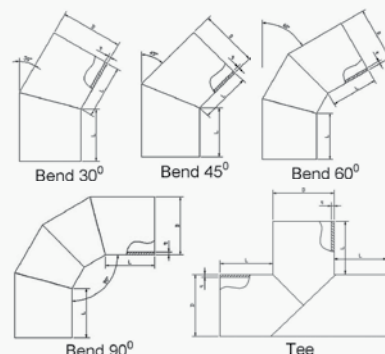

Fabricated Fittings

HDPE

DRAINAGE & SEWAGE PIPING

“NIC HDPE” drainage & sewage pipes are produced as per international standard EN 1519, DIN 19535 & DIN 19537. It can be used inside building for residential and industrial use as follows:

- Waste pipes for domestic waste waters (Low & high Temperatures)
- Ventilation pipes connected to waste water pipes
- Discharge of rain water inside the structure of building

“NIC HDPE” Pipes made as per EN 1519

Nominal Outside Diameter		Pipe series S 16 Wall Thickness		Pipe series S 12.5 Wall Thickness	
OD mm	Tolerance	T mm	Tolerance	T mm	Tolerance
32	+0.3 -0.0	3.0	+0.5 -0.0	3.0	+0.5 -0.0
40	+0.4 -0.0	3.0	+0.5 -0.0	3.0	+0.5 -0.0
50	+0.5 -0.0	3.0	+0.5 -0.0	3.0	+0.5 -0.0
63	+0.6 -0.0	3.0	+0.5 -0.0	3.0	+0.5 -0.0
75	+0.7 -0.0	3.0	+0.5 -0.0	3.0	+0.5 -0.0
90	+0.9 -0.0	3.0	+0.5 -0.0	3.5	+0.6 -0.0
110	+1.0 -0.0	3.4	+0.6 -0.0	4.2	+0.7 -0.0
125	+1.2 -0.0	3.9	+0.6 -0.0	4.8	+0.7 -0.0
160	+1.5 -0.0	4.9	+0.7 -0.0	6.2	+0.9 -0.0
200	+1.8 -0.0	6.2	+0.9 -0.0	7.7	+1.0 -0.0
250	+2.3 -0.0	7.7	+1.0 -0.0	9.6	+1.2 -0.0
315	+2.9 -0.0	9.7	+1.2 -0.0	12.1	+1.5 -0.0

Note: Imported fittings conforming to EN 1519 are available.

HDPE

CABLE DUCT & SUB DUCT



Smooth wall HDPE subduct for project in Kuwait

HDPE SMOOTH WALL CABLE DUCT & SUB DUCT

Sr. No.	Trade Size mm	Duct Thickness mm	Outer Dia. mm	Inner Dia. mm	Coil Length
1	25	2.0	25	21	200
2	32	2.0	32	28	200
3	40	2.0	40	36	200
4	40	3.5	40	33	200
5	50	2.0	50	46	200
6	50	4.0	50	42	200
7	110	5.0	110	100	100

Note:

- a. If required, duct can be supplied with pulling rope inside.
- b. Special sizes can be manufactured on request.

HDPE CORRUGATED CABLE DUCT & SUB DUCT

A. Single wall



Sr. No.	Trade Size mm	Duct Thickness mm	Outer Dia. mm	Inner Dia. mm	Coil Length m
1	20	2.1	20.8	16.5	200
2	32	3.2	34.0	27.5	200
3	40	3.9	41.8	34.0	200
4	50	4.3	53.0	44.4	200
5	60	5.0	65.0	55.0	100
6	70	5.0	75.0	65.0	100
7	100	7.2	116.0	101.0	100

Note: If required, duct can be supplied with pulling rope inside

B. Double wall (Inside smooth & outside corrugated)



Sr. No.	Trade Size mm	Duct Thickness mm	Outer Dia. mm	Inner Dia. mm	Pipe Length m
1	100	2.1	116.0	101.0	6
2	150	3.2	174.0	151.0	6
3	200	3.9	232.0	201.0	6

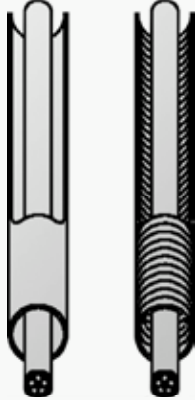

BENEFITS:

- 30% less friction than PVC, thus while pulling cables, it experiences less stress.
- Because of flexibility, HDPE duct eliminates need for special bends and sweeps.
- Faster installation and reduced labor costs.
- Fewer joints-better system integrity as duct is supplied in long length coils.
- Duct can be pulled over inside outer duct for long distances with minimum elongation.
- Wide variety of colours helps in easy identification when used as multiple inner ducts.
- High crushing strength protects cable.

APPLICABLE STANDARDS:

Standard	Title
ASTM D 570	Standard Test Method for Water Absorption of Plastics
ASTM D 638	Standard Test Method for Tensile Properties of Plastics
DIN 8074 & 8075	Dimensions and quality requirement.
BS EN ISO 9001	Quality standard for manufacturing.
MOC, Kuwait	Special requirements.

ACCESSORIES:

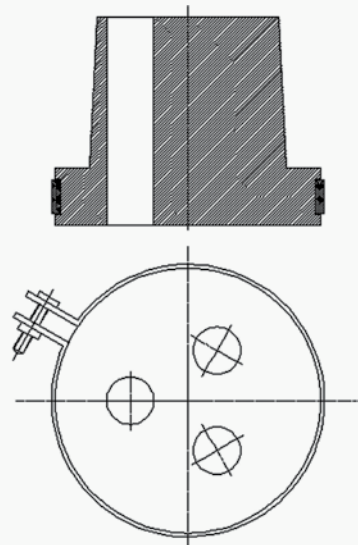
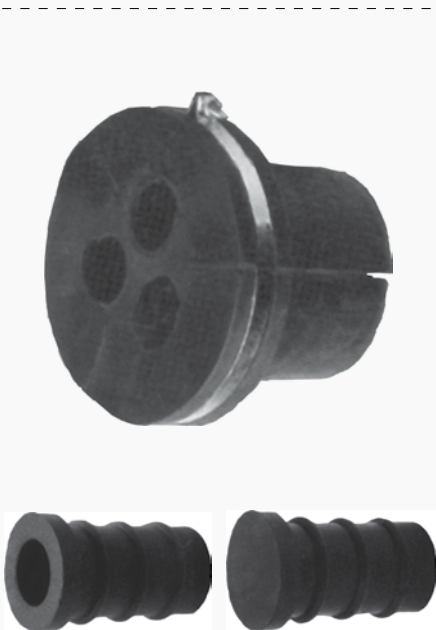

Rubber plug for PVC socket
to hold HDPE subduct

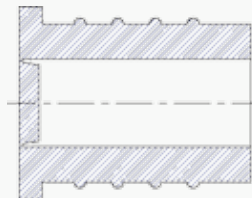

Blind rubber plug
for HDPE subduct.

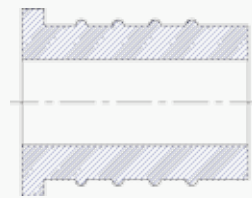

Rubber Plug to hold cable
in HDPE subduct.



Main Administration Shuwaikh

Tel: 24642100
Kuwait Hotline: 1844555
Ceramics Sales: 24836564

Working Hours*:

Morning Hours (Sunday - Thursday)

7:30am - 3:00pm

Evening Hours (Sunday - Wednesday)

5:00pm - 8:00pm

Saturday

7:30am - 2:00pm



Sulaibiya

Tel: 24642200

Working Hours*:

Saturday

7:30am - 2:00pm

Sunday - Thursday

7:30am - 3:00pm



Western Industrial Shuaiba

Tel: 24642300
Ceramics Factory: 23262714/10

Working Hours*:

Sunday - Thursday

7:30am - 3:00pm

Saturday

7:30am - 2:00pm



Industrial Shuwaikh Showroom

Industrial Shuwaikh2 - Block1 - Area 92
Al-Zaben Complex - Shops : 12,13,14
Tel. : 24642101/2/3/4/9
Fax : 24642110

Working Hours*:

Saturday - Thursday

7:00am-7:00pm for plastic products
9:00am-9:00pm for other products

Ceramics Showroom

Industrial Shuwaikh - Humaidhi Complex
Opposite to Bin Nisf Co.
Tel: 24950871/2 - Factory: 23262714/10

Working Hours*:

Sunday - Thursday: 9:00am - 9:00pm

For any sales inquiry: Fax: +965 24642063 - Email: sales@nicbm.com

* Working hours are subject to change according to holidays and occasions - Follow us on [Twitter](#) | [Instagram](#) | [WhatsApp](#) +965 99001150



NATIONAL INDUSTRIES COMPANY



شركة الصناعات الوطنية

Since 1960

www.nicbm.com

☎ 1 844 555

