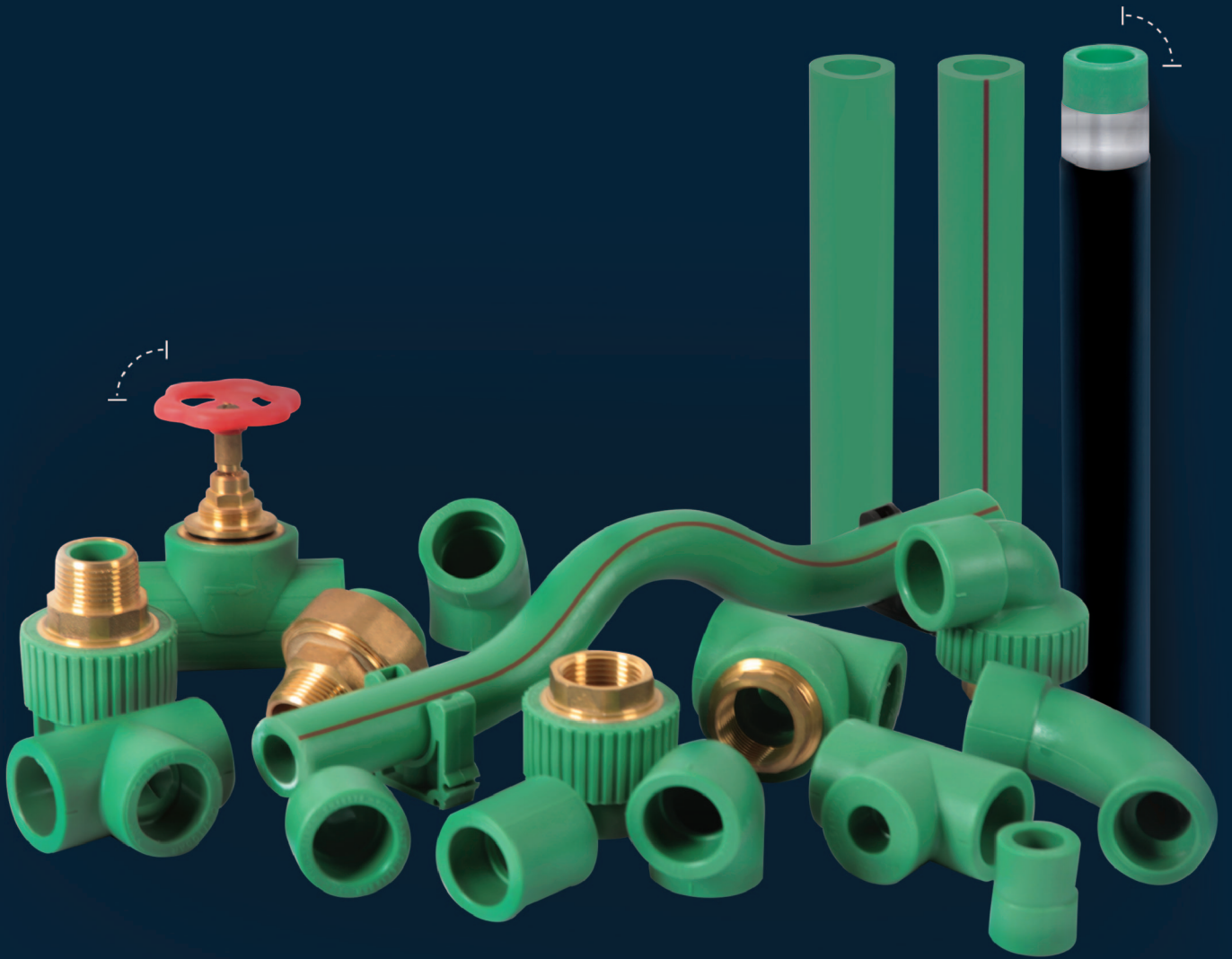




# PP-RCT

## TECHNICAL HANDBOOK

Pipes & Fittings



# **PP-RCT**

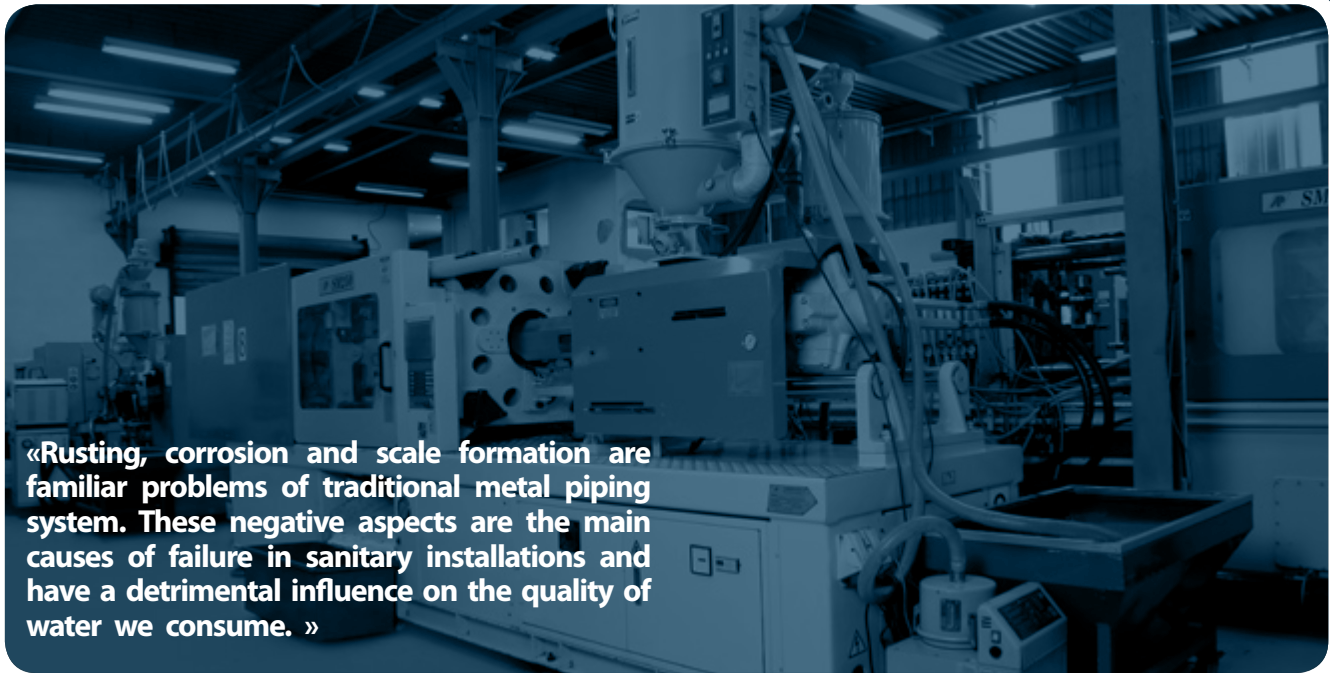
**TECHNICAL HANDBOOK**

Pipes & Fittings In Polypropylene Random

# TABLE OF CONTENT

The Ultimate piping System	04
Material Properties	05
<b>DESIGN FACTS</b>	
<b>Thermal Behavior</b>	<b>06</b>
Flow characteristics	09
<b>Guidelines for Pipe sizing</b>	<b>16</b>
Technical Information	19
<b>Interpretation of long-term hydrostatic stress application</b>	<b>31</b>
Laboratory	53
<b>WELDING</b>	
<b>Welding procedures of Apitherm Pipes</b>	<b>54</b>
Electro Fusion	58
Work Shop	59
<b>INSTALLATION</b>	
<b>Compensation for linear thermal expansion</b>	<b>60</b>
Anchoring Suggestions	62
<b>Riser Installation</b>	<b>63</b>
Exposed piping Installations	64
<b>Levelling of wall Outlets</b>	<b>66</b>
Wall Embedding Suggestions	67
<b>Pipe forming procedure</b>	<b>68</b>
Model of Installation	69
Quality Assurance	70
<b>REPAIRS</b>	
<b>Repair of a damaged pipe</b>	<b>72</b>
Repair of female threaded adapters	73
<b>FLOOR HEATING</b>	
<b>Floor Heating</b>	<b>74</b>
Typical floor Heating layout	75
<b>PRODUCT RANGE</b>	
<b>Product Range-Pipes</b>	<b>78</b>
Product Range-Fittings	82
<b>SPECIFICATIONS</b>	
<b>Handling plastic pipes &amp; Fittings</b>	<b>101</b>
Chemical Resistance	91
<b>System Inspection &amp; testing</b>	<b>100</b>
System specifications	101
Guarantee	102
ISO 9001:2008 Certification	104
SKZ Certification	105
TZW Certification	106

# THE ULTIMATE PIPING SYSTEM



«Rusting, corrosion and scale formation are familiar problems of traditional metal piping system. These negative aspects are the main causes of failure in sanitary installations and have a detrimental influence on the quality of water we consume.»

Plastic pipes do not rust or corrode. Their smooth inner surface prevents scale formation.

Heat stabilized Polypropylene Random Copolymer PP-r (Type 3) is a designed polymer. It is purposely made to satisfy all demanding criteria of modern building designers and water specialists.

Over the past 10 years, the use of polypropylene pipe PP-r for cold and hot water applications grew substantially in Europe and the Middle East.

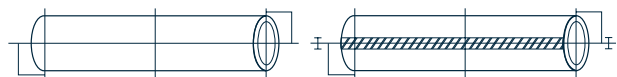
The PP-r sanitary pipe system represents a proven, economic, safe and trouble free system made entirely of plastic material especially designed to last for the lifetime of the building.

Advanced Plastic Industries s.a.l – **Api** – supplies an extensive range of PP-RCT pipes and fittings under the trademark Apitherm®.

Apitherm® pipes are produced according to the general quality requirements of EN-ISO 15874 (Class 2 & Class 5) and DIN 8077, Din 8078 standards.

Raw materials used in the Apitherm® pipe system are certified by the Gelsenkirchen hygiene Institute to fulfill the KTW requirements for the drinking water, and certified by Suddeutsche Kunststoff Zentrum (SKZ) to fulfill the hydrostatic strength requirements in DIN 8078.

Advanced plastic Industries' dedication to quality together with our commitment to superior customer service and support are your assurance of a long-lasting and trouble free plumbing system.



Material Characteristics	
The main characteristics of Apitherm® pipe system are:	
Long life	High thermal insulation
Resistance to corrosion	Low level of pressure loss
Resistance to frost	High impact strength
Resistance to chemicals	High hydrostatic strength under pressure
Taste and odor neutral	Excellent weldability
High acoustic insulation	Quick and safe installation

Fields of Application (PP-RCT)
Apitherm® pipe system can be used for:
Class1: Hot Water Supply 60°C
Class2: Hot Water supply 70°C
Class4: Underfloor heating and low temperature radiators
Class5: High temperature radiators

# MATERIAL PROPERTIES

## MATERIAL PROPERTIES

PROPERTY	MEASURING TECHNIQUE	UNIT	VALUE
Coefficient of viscosity	EN ISO 1628	cm <sup>3</sup> /g	400
Average molar weight	EN ISO 1628	-	470,000
Melting index MFI 190/5 MFI 230/S	ISO/R 1133 Procedure 5 Procedure 14	g/10 min. g/10 min.	0.6 1.8
Density	ISO / r 1183	g/cm <sup>3</sup>	0.895
Melting range	Polarizing microscope	C	140 - 150
Double voltage Ultimate tensile strength Expansion at tear	ISO / R 527 Char speed D Test bar fig. 2	N/mm <sup>2</sup> N/mm <sup>2</sup> %	21 40 800
Ball-pressure hardness	ISO 2039 (H 358/30)	N/mm <sup>2</sup>	40
Bending stress at 3,5% Edge fiber expansion	ISO 178 Test specimen 5.1	N/mm <sup>2</sup>	20
Modulus of elasticity	ISO 178	N/mm <sup>2</sup>	800
Modulus of transverse elasticity -10 C 0 C 10 C 20 C 30 C 40 C 50 C 60 C	ISO / R 537 Method A	N/mm <sup>2</sup> N/mm <sup>2</sup> N/mm <sup>2</sup> N/mm <sup>2</sup> N/mm <sup>2</sup> N/mm <sup>2</sup> N/mm <sup>2</sup> N/mm <sup>2</sup>	1,100 770 500 370 300 240 180 140
Tensile properties further to impact bending test at 0 C	DIN 8078		No fracture
Impact strength (According to Charpy) RT 0 C -10 C	ISO / R 179 Test bar in conformity with fig. 2	mJ/mm <sup>2</sup> mJ/mm <sup>2</sup> mJ/mm <sup>2</sup>	No fracture No fracture No fracture
Notched bar impact value (According to Carpy) RT 0 C 20 C	ISO / R 179 Test bar in conformity with fig. 2	mJ/mm <sup>2</sup> mJ/mm <sup>2</sup> mJ/mm <sup>2</sup>	15 4.2 2.5
Expansion Coefficient Caloric conductivity at 20 C Specific Heat at 20 C	VDE 0304 Part 1§4 DIN 52612 Adiabatic calorimeter	K -1 W/m K kJ/Kg K	1.5 x 10 <sup>-4</sup> 0.24 2.0

# SPECIFIC LINEAR THERMAL EXPANSION

Plastics like other solids expand on heating and their ability to expand depends on their molecular structure. As a consequence of the rising temperature, the amplitude of molecules increases causing an increase in the average distance between them. That illustrates the phenomenon of thermal linear expansion.

Accordingly, when exposed to an increase in temperature, PP-r pipes undergo a reversible linear expansion. This increase in length is proportional to the original length of the pipe  $L_0$ , expressed in Lm, and the change in temperature  $\Delta T$  expressed in °C. The diameter of the pipe does have a function in this computation.

The coefficient of linear expansion  $\alpha$  is defined as the fractional change in length ( $\Delta L$ ), expressed in mm, for one degree Celsius (1 °C) rise in temperature. The coefficient  $\Delta f$  is a constant that solely depends on the material that an object is made from. The coefficient of linear thermal expansion of PP-r material is  $15 \times 10^{-5} K^{-1} = 0.15 \text{mm/m}^\circ\text{C}$ .

The rate of expansion can be calculated as follows:

$$\Delta L = \alpha L_0 (\Delta T)$$

**Where:**

$\Delta L$  = amount of expansion in mm

$\alpha$  = coefficient of linear expansion in mm/m°C

$L_0$  = original length of the pipe in m

$\Delta T$  = Difference between ambient temperature and operating temperatures in °C

**TABLE 1: LINEAR EXPANSION TABLE FOR APITHERM® PIPES**

PIPE LENGTH L(m)	$\Delta T$ (°C)						
	10	20	30	40	50	60	70
1.0	1.50	3.00	4.50	6.00	7.50	9.00	10.50
1.5	2.25	4.50	6.75	9.00	11.25	13.50	15.75
2.0	3.00	6.00	9.00	12.00	15.00	18.00	21.00
2.5	3.75	7.50	11.25	15.00	18.75	22.50	26.25
3.0	4.50	9.00	13.50	18.00	22.50	27.00	31.50
3.5	5.25	10.50	15.75	21.00	26.25	31.50	36.75
4.0	6.00	12.00	18.00	24.00	30.00	36.00	42.00
4.5	6.75	13.50	20.25	27.00	33.75	40.50	47.25
5.0	7.50	15.00	22.50	30.00	37.50	45.00	52.50
5.5	8.25	16.50	24.75	33.00	41.25	49.50	57.75
6.0	9.00	18.00	27.00	36.00	45.00	54.00	63.00
6.5	9.75	19.50	29.25	39.00	48.75	58.50	68.25
7.0	10.50	21.00	31.50	42.00	52.50	63.00	73.50
7.5	11.25	22.50	33.75	45.00	56.25	67.50	78.75
8.0	12.00	24.00	36.00	48.00	60.00	72.00	84.00

# SPECIFIC FORCE OF EXPANSION

As with metal pipes, PP-r pipes are commonly embedded in walls and concrete slabs in both cold and hot weather applications. Compared to other material, the force of expansion is insignificant (2 to 3% of that of metal pipes). The force of expansion of PP-r pipes is proportional to the coefficient of linear expansion and module of elasticity of PP-r, the temperature difference, the size of the pipe and not by the length of the pipes.

The specific force of expansion can be calculated as follows

$$F_T = E A \alpha \Delta T$$

Where:

- $F_T$  = force of expansion in Newtons
- $E$  = Elastic Modulus at the specified operating temperature ( $T_0$ ) in MPa
- $A$  = Annular area of pipe, or surface area of the pipe material in the cross section in  $mm^2$  ( $A = \pi e (D - e)$ );  $e$ : wall thickness &  $D$ : outer diameter of the pipe.
- $\alpha$  = coefficient of linear expansion ( $\alpha = 15 \times 10^{-5} \text{ m/m}^\circ\text{C}$ )
- $\Delta T$  = Difference between the ambient temperature and the operating temperature in  $^\circ\text{C}$  ( $\Delta T = T - T_0$ )

$T_0$	E-MODULE	$T_0$	E-MODULE
0	1681	45	421
5	1441	50	372
10	1231	55	333
15	1049	60	301
20	893	65	274
25	761	70	249
30	650	75	225
35	558	80	199
40	482	85	190

To in  $^\circ\text{C}$  and E-Module in MPa or 106 N/m<sup>2</sup>

**• Example:**

Consider 32 mm PP-r pipe, class 1 (32x5.4) that carries water at 60 C is placed in an ambient temperature of 45°C

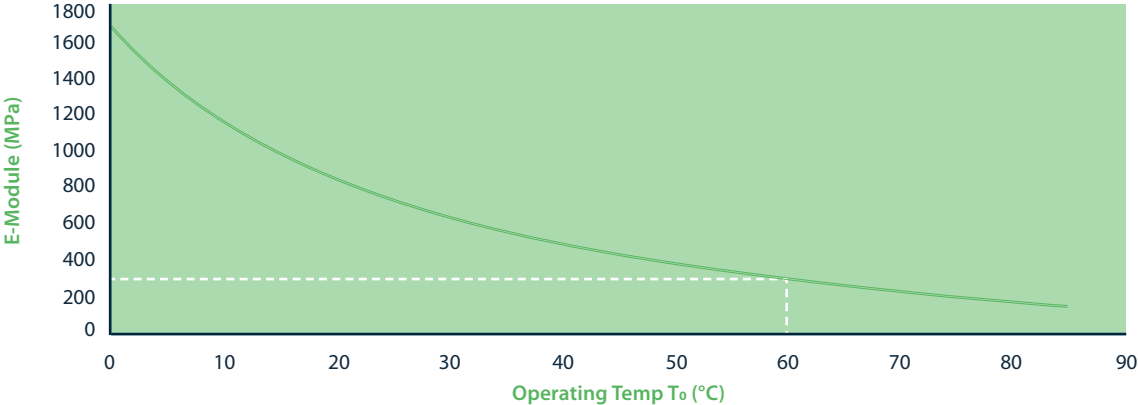
$$T_0 = 60^\circ\text{C} \quad |\Delta T| = T - T_0 = |45 - 60| = 15^\circ\text{C}$$

$$F_T = EA \alpha \Delta T$$

$$F_T = (301 \text{ MPa}) \times (\pi \times 5.4 \times (32 - 5.4) \text{ mm}^2) \times (15 \times 10^{-5} \text{ m/m}^\circ\text{C}) \times 15^\circ\text{C}$$

$$F_T = 305.5 \text{ N}$$

Note: E should be in MPa and area in mm<sup>2</sup> for units to cancel out



# SPECIFIC FORCE OF EXPANSION

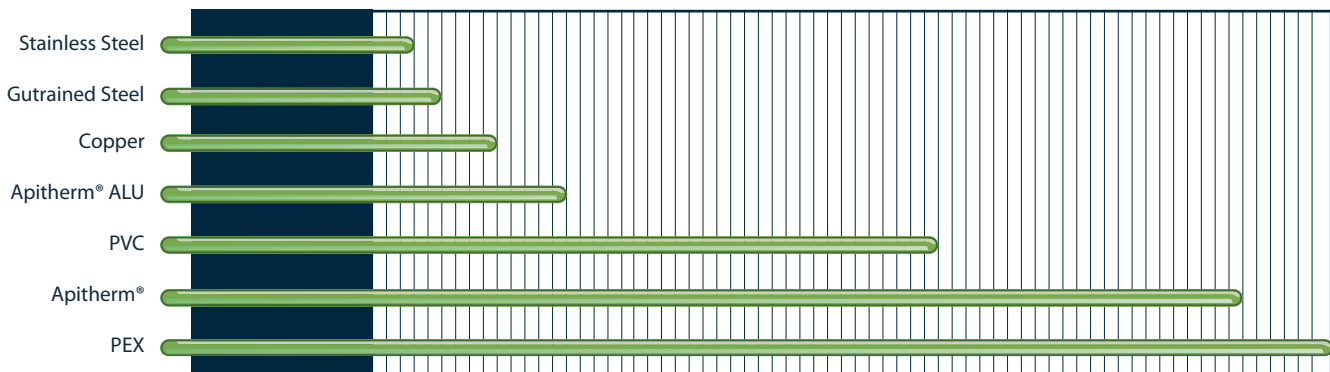
In embedded PP-RU installations, as temperature of the pipeline rises, expansion forces come to play and as a consequence the pipe attempts to expand. However, the compression strains and tensile stress created by the surrounding concrete or fixed clamps, oppose the emerging and relatively weak expansion forces and overcome them. No special compensation is required in concealed piping installations.

Tables below showing the force of expansion  $F_t$  of same size pipe for various pipe materials.

MATERIAL	PIPE SIZE	$F_t$ AT $r_t$ 40 °C
Galvanized Steel	27.3 x 3.2	27,650 N
Copper	28.0 x 1.2	8,440 N
Apitherm® (Alu-Pipe)	25.0 x 4.2	850 N
PVC	25.0 x 3.2	540 N
Apitherm®	25.0 x 4.2	590 N
PEX	25.0 x 3.5	1,150 N

PP-RCT pipes have a weak force of expansion  $F_t = 590$  N

Linear Thermal Expansion of pipe materials at 50m (length) and 50°C ( $\Delta T$ )



PIPE SIZE	$F_t$ AT $\Delta T$ 40 °C
26.9 x 2.0	17,840 N
27.3 x 3.2	27,650 N
28 x 1.2	8,440 N
(25 x 4.2)	850 N
25 x 3.2	540 N
25.0 x 4.2	590 N
25 x 3.5	1,150 N



# PIPE FRICTION & FLOW RATE

## PP-RCT CLASS 5 SERIES 2.5

TEMPERATURE: 20° C

ROUGHNESS: 0.007 MM

Q		INTERNAL DIAMETER							
		16 mm	20 mm	25 mm	32 mm	40 mm	50 mm	63 mm	75 mm
		10.6 mm	13.2 mm	16.6 mm	21.2 mm	26.6 mm	33.2 mm	42 mm	50 mm
0.01	R	0.36	0.13	0.04	0.01	0.01	0.00	0.00	0.00
	V	0.11	0.07	0.05	0.03	0.02	0.01	0.01	0.01
0.02	R	1.14	0.41	0.14	0.04	0.02	0.01	0.00	0.00
	V	0.23	0.15	0.09	0.06	0.04	0.02	0.01	0.01
0.03	R	2.28	0.81	0.28	1.09	0.03	0.01	0.00	0.00
	V	0.34	0.22	0.14	0.08	0.05	0.03	0.02	0.02
0.04	R	3.73	1.32	0.45	0.14	0.05	0.02	0.01	0.00
	V	0.45	0.29	0.18	0.11	0.07	0.05	0.03	0.02
0.05	R	5.49	1.94	0.66	0.21	0.07	0.03	0.01	0.00
	V	0.57	0.37	0.23	0.14	0.09	0.06	0.04	0.03
0.06	R	7.53	2.66	0.90	0.28	0.10	0.03	0.01	0.01
	V	0.68	0.44	0.28	0.17	0.11	0.07	0.04	0.03
0.07	R	9.86	3.47	1.17	0.37	0.13	0.04	0.01	0.01
	V	0.79	0.51	0.32	0.20	0.13	0.08	0.05	0.04
0.08	R	12.47	4.37	1.47	0.46	0.16	0.06	0.02	0.01
	V	0.91	0.58	0.37	0.23	0.14	0.09	0.06	0.04
0.09	R	15.34	5.37	1.80	0.57	0.19	0.07	0.02	0.01
	V	1.02	0.66	0.42	0.25	0.16	0.10	0.06	0.05
0.1	R	18.47	6.46	2.17	0.68	0.23	0.08	0.03	0.01
	V	1.13	0.73	0.46	0.28	0.18	0.12	0.07	0.05
0.2	R	63.57	22.00	7.31	2.27	0.77	0.27	0.09	0.04
	V	2.27	1.46	0.92	0.57	0.36	0.23	0.14	0.10
0.4	R	224.10	76.61	25.15	7.72	2.60	0.90	0.29	0.13
	V	4.53	2.92	1.85	1.13	0.72	0.46	0.29	0.20
0.6	R	475.48	160.83	52.37	15.97	5.34	1.84	0.60	0.26
	V	6.80	4.38	2.77	1.70	1.08	0.69	0.43	0.31
0.8	R	814.71	273.71	88.55	26.84	8.94	3.07	1.00	0.43
	V	9.07	5.85	3.70	2.27	1.44	0.92	0.58	0.41
1	R	1241.29	414.79	133.50	40.27	13.37	4.58	1.48	0.64
	V	11.33	7.31	4.62	2.83	1.80	1.16	0.72	0.51
2	R	4673.00	1536.61	486.28	144.28	47.25	16.02	5.12	2.21
	V	22.66	14.61	9.24	5.67	3.60	2.31	1.44	1.02
3	R	9819.81	3346.06	1048.84	308.00	99.97	33.63	10.68	4.59
	V	34.00	21.92	13.86	8.50	5.40	3.47	2.17	1.53
4	R		5840.05	1819.23	530.38	171.02	57.20	18.07	7.73
	V		29.23	18.48	11.33	7.20	4.62	2.89	2.04
5	R		9017.58	2796.69	810.99	260.16	86.59	27.23	11.62
	V		36.54	23.10	14.16	9.00	5.78	3.61	2.55
6	R			3980.87	1149.58	367.24	121.75	38.14	16.23
	V			27.72	17.00	10.80	6.93	4.33	3.06
7	R			5371.59	1546.02	492.19	162.62	50.78	21.56
	V			32.34	19.83	12.60	8.09	5.05	3.57
8	R			6968.73	200.23	634.95	209.17	65.12	27.59
	V			36.96	22.66	14.40	9.24	5.77	4.07
9	R			8772.22	2512.15	634.95	261.31	81.16	34.33
	V			41.58	25.50	14.40	10.40	6.50	4.58
10	R			10782.00	3081.74	795.48	319.22	98.88	41.83
	V			46.21	28.33	16.20	11.55	7.22	5.09

Q = Flow rate (Vs)

R = pressure gradient (mbar/m)

v = Velocity (m/s)

# PIPE FRICTION & FLOW RATE

## PP-RCT CLASS 5 SERIES 2.5

TEMPERATURE: 70° C

ROUGHNESS: 0.007 MM

Q		INTERNAL DIAMETER							
		16 mm	20 mm	25 mm	32 mm	40 mm	50 mm	63 mm	75 mm
0.01	R	0.22	0.08	0.03	0.01	0.00	0.00	0.00	0.00
	V	0.11	0.07	0.05	0.03	0.02	0.01	0.01	0.01
0.02	R	0.74	0.26	0.09	0.03	0.01	0.00	0.00	0.00
	V	0.23	0.15	0.09	0.06	0.04	0.02	0.01	0.01
0.03	R	1.51	0.53	0.18	0.05	0.02	0.01	0.00	0.00
	V	0.34	0.22	0.14	0.08	0.05	0.03	0.02	0.02
0.04	R	2.53	0.88	0.29	0.90	0.03	0.01	0.00	0.00
	V	0.45	0.29	0.18	0.11	0.07	0.05	0.03	0.02
0.05	R	3.78	1.30	0.43	0.13	0.05	0.02	0.01	0.00
	V	0.57	0.37	0.23	0.14	0.09	0.06	0.04	0.03
0.06	R	5.26	1.81	0.60	0.18	0.06	0.02	0.01	0.00
	V	0.68	0.44	0.28	0.17	0.11	0.07	0.04	0.03
0.07	R	6.97	2.39	0.79	0.24	0.08	0.03	0.01	0.00
	V	0.79	0.51	0.32	0.20	0.13	0.08	0.05	0.04
0.08	R	8.90	3.04	1.00	0.31	0.10	0.04	0.01	0.01
	V	0.91	0.58	0.37	0.23	0.14	0.09	0.06	0.04
0.09	R	11.05	3.77	1.24	0.38	0.13	0.04	0.01	0.01
	V	1.02	0.66	0.42	0.25	0.16	0.10	0.06	0.05
0.1	R	13.42	4.57	1.49	0.46	0.15	0.05	0.02	0.01
	V	1.13	0.73	0.46	0.28	0.18	0.12	0.07	0.05
0.2	R	49.03	16.41	5.29	1.60	0.53	0.18	0.06	0.03
	V	2.27	1.46	0.92	0.57	0.36	0.23	0.14	0.10
0.4	R	184.10	60.63	19.22	5.71	1.87	0.64	0.20	0.09
	V	4.53	2.92	1.85	1.13	0.72	0.46	0.29	0.20
0.6	R	403.68	131.83	41.39	12.18	3.96	1.33	0.42	0.18
	V	6.80	4.38	2.77	1.70	1.08	0.69	0.43	0.31
0.8	R	707.59	229.87	71.71	20.94	6.76	2.27	0.72	0.31
	V	9.07	5.85	3.70	2.27	1.44	0.92	0.58	0.41
1	R	1095.77	354.70	110.16	32.00	10.28	3.43	1.08	0.46
	V	11.33	7.31	4.62	2.83	1.80	1.16	0.72	0.51
2	R	4300.28	1380.39	423.84	121.30	38.38	12.60	3.91	1.65
	V	22.66	14.61	9.24	5.67	3.60	2.31	1.44	1.02
3	R	9610.45	3074.93	939.69	267.13	83.88	27.31	8.39	3.53
	V	34.00	21.92	13.86	8.50	5.40	3.47	2.17	1.53
4	R		5438.21	1657.59	469.38	146.69	47.50	14.51	6.06
	V		29.23	18.48	11.33	7.20	4.62	2.89	2.04
5	R		8470.22	2577.52	728.04	226.81	73.15	22.24	9.26
	V		36.54	23.10	14.16	9.00	5.78	3.61	2.55
6	R			3699.47	1043.10	324.22	104.27	31.58	13.11
	V		43.84	27.72	17.00	10.80	6.93	4.33	3.06
7	R			5023.43	1414.55	438.92	140.85	42.54	17.62
	V		51.15	32.34	19.83	12.60	8.09	5.05	3.57
8	R			6549.41	1842.38	570.90	182.88	55.10	22.78
	V		58.46	36.96	22.66	14.40	9.24	5.77	4.07
9	R			8277.40	2326.61	720.17	230.36	69.27	28.59
	V		65.77	41.58	25.50	16.20	10.40	6.50	4.58
10	R			10207.40	2867.22	886.72	283.30	85.05	35.05
	V		73.07	46.21	28.33	17.99	11.55	7.22	5.09

Q = Flow rate (Vs)

R = pressure gradient (mbar/m)

v = Velocity (m/s)

# PIPE FRICTION & FLOW RATE

## PP-RCT CLASS 2 SERIES 3.2

TEMPERATURE: 20° C

ROUGHNESS: 0.007 MM

Q		INTERNAL DIAMETER							
		16 mm	20 mm	25 mm	32 mm	40 mm	50 mm	63 mm	75 mm
		11.6mm	14.4mm	18mm	23.2mm	29mm	36.2mm	45.8mm	54.4mm
0.01	R	0.24	0.09	0.03	0.01	0.00	0.00	0.00	0.00
	V	0.09	0.06	0.04	0.02	0.02	0.01	0.01	0.00
0.02	R	0.75	0.27	0.10	0.03	0.01	0.00	0.00	0.00
	V	0.19	0.12	0.08	0.05	0.03	0.02	0.01	0.01
0.03	R	1.49	0.53	0.19	0.06	0.02	0.01	0.00	0.00
	V	0.28	0.18	0.12	0.07	0.05	0.03	0.02	0.01
0.04	R	2.43	0.88	0.31	0.09	0.03	0.01	0.00	0.00
	V	0.38	0.25	0.16	0.09	0.06	0.04	0.02	0.02
0.05	R	3.58	1.28	0.45	0.14	0.05	0.02	0.01	0.00
	V	0.47	0.31	0.20	0.12	0.08	0.05	0.03	0.02
0.06	R	4.91	1.76	0.61	0.18	0.06	0.02	0.01	0.00
	V	0.57	0.37	0.24	0.14	0.09	0.06	0.04	0.03
0.07	R	6.42	2.29	0.80	0.24	0.08	0.03	0.01	0.00
	V	0.66	0.43	0.28	0.17	0.11	0.07	0.04	0.03
0.08	R	8.10	2.89	1.00	0.30	0.11	0.04	0.01	0.01
	V	0.76	0.49	0.31	0.19	0.12	0.08	0.05	0.03
0.09	R	9.96	3.55	1.23	0.37	0.13	0.05	0.02	0.01
	V	0.85	0.55	0.35	0.21	0.14	0.09	0.05	0.04
0.1	R	11.99	4.27	1.48	0.44	0.15	0.05	0.02	0.01
	V	0.95	0.61	0.39	0.24	0.15	0.10	0.06	0.04
0.2	R	41.06	14.47	4.96	1.48	0.52	0.18	0.06	0.03
	V	1.89	1.23	0.79	0.47	0.30	0.19	0.12	0.09
0.4	R	144.14	50.14	17.00	5.01	1.72	0.60	0.19	0.09
	V	3.78	2.46	1.57	0.95	0.61	0.39	0.24	0.17
0.6	R	304.16	104.92	35.31	10.33	3.53	1.28	0.40	0.17
	V	5.68	3.68	2.36	1.42	0.91	0.58	0.36	0.26
0.8	R	519.69	178.11	59.59	17.33	5.89	2.03	0.66	0.29
	V	7.57	4.91	3.14	1.89	1.21	0.78	0.49	0.34
1	R	790.03	269.36	89.67	25.96	8.80	3.02	0.98	0.43
	V	9.46	6.14	3.93	2.37	1.51	0.97	0.61	0.43
2	R	2954.90	991.40	324.78	92.49	30.97	10.52	3.37	1.47
	V	18.92	12.28	7.86	4.73	3.03	1.94	1.21	0.86
3	R	6466.73	2151.18	698.09	196.72	65.32	22.03	7.01	3.05
	V	28.39	18.42	11.79	7.10	4.54	2.91	1.82	1.29
4	R		3746.05	1207.99	337.85	111.47	37.39	11.85	5.13
	V		24.56	15.72	9.46	6.06	3.89	2.43	1.72
5	R		5775.09	1853.84	515.54	169.24	56.51	17.83	7.71
	V		30.70	19.65	11.83	7.57	4.86	3.03	2.15
6	R			2635.32	729.00	238.53	79.34	24.94	10.75
	V			23.58	14.19	9.08	5.83	3.64	2.58
7	R			3552.27	979.86	319.26	105.84	33.16	14.27
	V			27.51	16.56	10.60	6.80	4.25	3.01
8	R			4604.57	1266.31	411.38	135.98	42.48	18.25
	V			31.44	18.92	12.11	7.77	4.86	3.44
9	R			5792.17	1588.87	514.87	169.75	52.89	22.68
	V			35.37	21.29	13.63	8.74	5.46	3.87
10	R			7115.01	1947.54	629.71	207.13	64.39	27.57
	V			39.30	23.66	15.14	9.72	6.07	4.30

Q = Flow rate (Vs)

R = pressure gradient (mbar/m)

v = Velocity (m/s)

# PIPE FRICTION AND FLOW RATE

## PP-RCT CLASS 2 SERIES 3.2

TEMPERATURE: 70° C

ROUGHNESS: 0.007 MM

Q		INTERNAL DIAMETER							
		16 mm	20 mm	25 mm	32 mm	40 mm	50 mm	63 mm	75 mm
0.01	R	11.6 mm	14.4 mm	18 mm	23.2 mm	29 mm	36.2 mm	45.8 mm	54.4 mm
	V	0.14	0.05	0.02	0.01	0.00	0.00	0.00	0.00
0.02	R	0.09	0.06	0.04	0.02	0.02	0.01	0.01	0.00
	V	0.48	0.17	0.06	0.02	0.01	0.00	0.00	0.00
0.03	R	0.19	0.12	0.08	0.05	0.03	0.02	0.01	0.01
	V	0.98	0.35	0.12	0.04	0.01	0.00	0.00	0.00
0.04	R	0.28	0.18	0.12	0.07	0.05	0.03	0.02	0.01
	V	1.63	0.58	0.20	0.06	0.02	0.01	0.00	0.00
0.05	R	0.38	0.25	0.16	0.09	0.06	0.04	0.02	0.02
	V	2.44	0.86	0.29	0.09	0.03	0.01	0.00	0.00
0.06	R	0.47	0.31	0.20	0.12	0.08	0.05	0.03	0.02
	V	3.39	1.19	0.40	0.12	0.04	0.01	0.00	0.00
0.07	R	0.57	0.37	0.24	0.14	0.09	0.06	0.04	0.03
	V	4.48	1.57	0.53	0.16	0.08	0.02	0.01	0.00
0.08	R	0.66	0.43	0.28	0.17	0.11	0.07	0.04	0.03
	V	5.72	1.99	0.68	0.20	0.07	0.02	0.01	0.00
0.09	R	0.76	0.49	0.31	0.19	0.12	0.08	0.05	0.03
	V	7.09	2.47	0.84	0.02	0.08	0.03	0.01	0.00
0.1	R	0.85	0.55	0.35	0.21	0.14	0.09	0.05	0.04
	V	8.61	2.99	1.01	0.30	0.10	0.04	0.01	0.01
0.2	R	0.95	0.61	0.39	0.24	0.15	0.10	0.06	0.04
	V	31.23	10.67	3.56	1.03	0.35	0.12	0.04	0.02
0.4	R	1.89	1.23	0.79	0.47	0.30	0.19	0.12	0.09
	V	116.48	39.14	12.85	3.66	1.23	0.42	0.13	0.06
0.6	R	3.78	2.46	1.57	0.95	0.61	0.39	0.24	0.17
	V	254.56	84.80	27.56	7.78	2.59	0.87	0.28	0.12
0.8	R	5.68	3.68	2.36	1.42	0.91	0.58	0.36	0.26
	V	445.30	147.53	47.65	13.35	4.41	1.48	0.47	0.20
1	R	7.57	4.91	3.14	1.89	1.21	0.78	0.49	0.34
	V	688.65	227.27	73.06	20.35	6.69	2.24	0.71	0.31
2	R	9.46	6.14	3.93	2.37	1.51	0.97	0.61	0.43
	V	2694.06	880.93	279.81	76.70	24.84	8.18	2.55	1.09
3	R	18.92	12.28	7.86	4.73	3.03	1.94	1.21	0.86
	V	6013.57	1959.17	619.08	168.41	54.10	17.67	5.45	2.32
4	R	28.39	18.42	11.79	7.10	4.54	2.91	1.82	1.29
	V		3461.87	1090.79	295.41	94.42	30.66	9.40	3.99
5	R		24.56	15.72	9.46	6.06	3.89	2.43	1.72
	V		5389.01	1694.91	457.68	145.78	47.14	14.38	6.08
6	R		30.70	19.65	11.83	7.57	4.86	3.03	2.15
	V			2431.42	655.19	208.17	67.11	20.39	8.59
7	R			23.58	14.19	9.08	5.83	3.64	2.58
	V			3300.33	887.96	281.59	90.56	27.44	11.53
8	R			27.51	16.56	10.60	6.80	4.25	3.01
	V			4301.63	1155.96	366.04	117.49	35.50	14.89
9	R			31.44	18.92	12.11	7.77	4.86	3.44
	V			5435.31	1459.22	461.51	147.90	44.60	18.67
10	R			35.37	21.29	13.63	8.74	5.46	3.87
	V			6701.39	1797.72	568.00	181.79	54.72	22.87
				39.30	23.66	15.14	9.72	6.07	4.30

Q = Flow rate (Vs)

R = pressure gradient (mbar/m)

v = Velocity (m/s)

# CORRECTION VALUE C OF LOSS FOR APITHERM® FITTINGS

NO.	RESISTANCE	GRAPHICAL REPRESENTATION	CORRECTION VALUE $\xi$ OF LOSS
1	Socket		0,25
2 2a	Reduction to 2 diameters Reduction from 3 diameters		0,55 0,85
3	Angle 90		1,20
4	Angle 45		0,6
5 5a	T-piece (separation) T-piece reduced		1,8 3,6
6 6a	T-piece (conjunction) T-piece reduced		1,3 2,6
7 7a	T-piece (antirotation) T-piece reduced		4,2 9,0
8 8a	T-piece (antirotation) T-piece reduced		2,2 5,0
9	t-piece with transition		0,8
10	Transition with outside diameter, without pendant		0,4
11	Transition angle with outside diameter, without pendant		2,2
12	Transition angle with outside diameter, (reduced) without pendant		2,5

## Pressure loss due to Apitherm® fittings

When performing detailed flow analysis for a system the head loss due to fittings installed must be taken in consideration to optimize the system design and functionality.

The head loss,  $Z$ , for each type of fitting is calculated in accordance with the following equation:

$$Z = \xi(v^2 \cdot \rho) / 2$$

Where:

$\xi$  is the loss factor (to be taken from the table on the left)  $v$  is the kinematical viscosity  
 $\rho$  is the density of water

The total head loss in the piping system (except for losses in appliances) is obtained as the sum of the pipe resistance head loss and the head loss due to fittings resistance, as expressed by the following equation:

$$\Delta p = \sum (l.R + Z)$$

# PRESSURE LOSSES

## HEAD LOSS

Home water supply systems must be designed and implemented to achieve the following basic objectives

- 1- To deliver an adequate volume of water to the most hydraulically remote fixture (draw off point) during minimum pressure and maximum flow conditions
- 2- To provide adequate water pressure to the most hydraulically remote fixture (draw off point) during minimum pressure and maximum flow conditions
- 3- To prevent excessive water velocity during maximum flow conditions

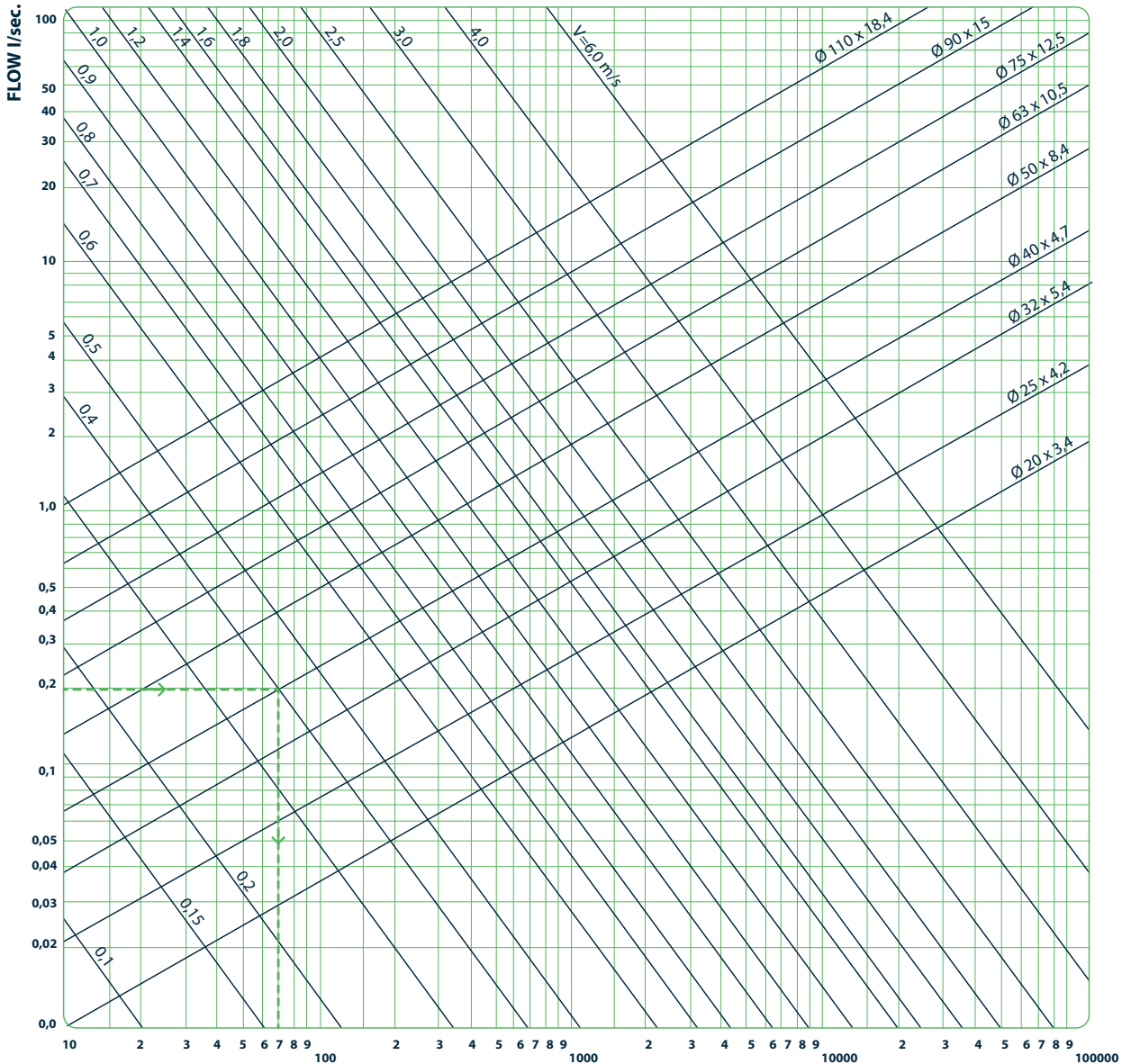
The diagrams and instructions on this page and the following few pages offer guidelines and general information for designing home water supply systems for years of trouble-free performance. The process of pipe sizing is based on a calculation of the head loss occurring in pipework, which is a function of the pipe material, pipe diameter, pipe length, flow rate, as well as of the number and size of draw off fittings served by a pipe.

It is derived from the design flow rate required at each draw off point and must allow for the probable simultaneous demand and the resulting peak flow rate in a given section of pipework.

### Pressure losses (Head Loss)

The pressure losses for distribution in API piping system can be calculated with the assistance of the following charts:

#### Pressure loss diagram for Class 5 pipes:



Pressure loss: Pa/m. (10.000 Pa = 0,1 bar = 1 m. c.a.)

PRESSURE LOSS Pa/m

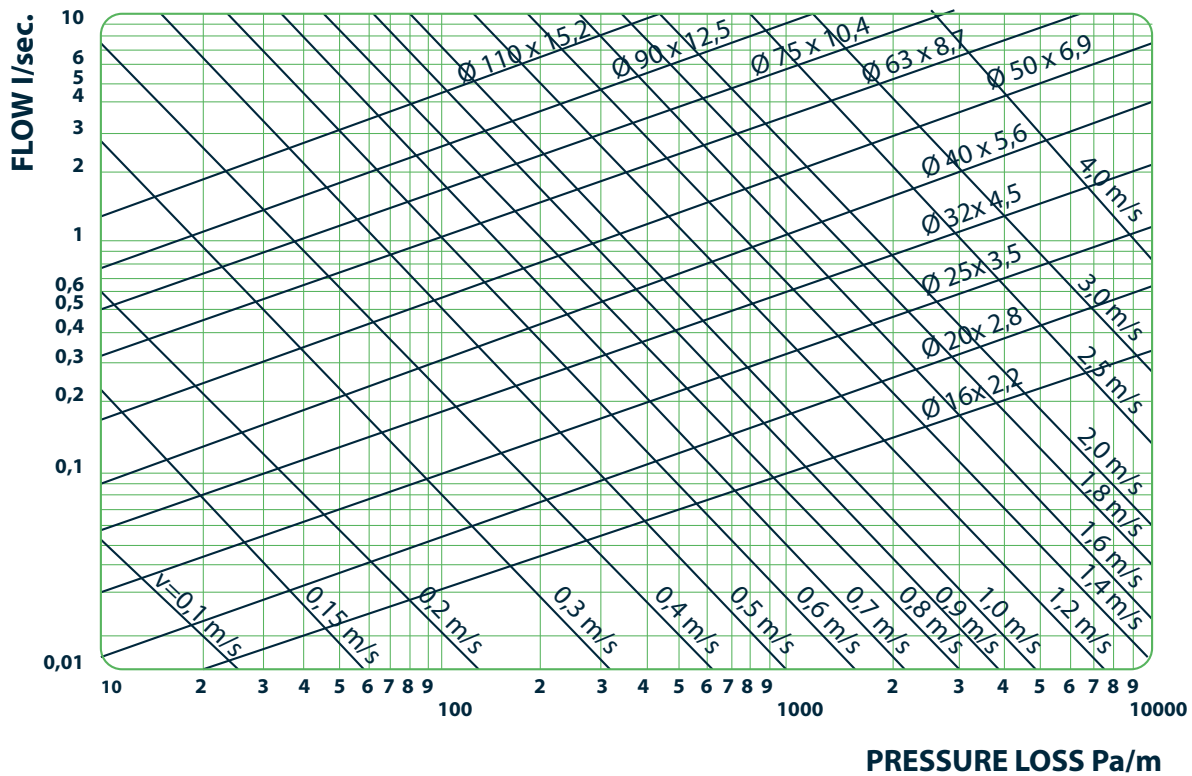
# PRESSURE LOSSES

## HEAD LOSS

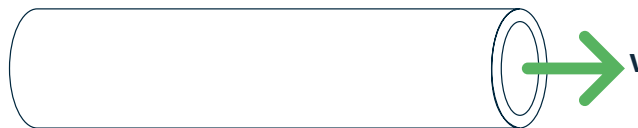
• **Example:**

Pipe: 40 × 6,7 mm  
 Flow: 0,2 l/s  
 Water velocity: 0,4m/sec.  
 Pressure loss: 70Pa/m. = 7 mm/m. aprox

**Pressure loss diagram for Class 2 pipes:**



**Velocity of Water flow**



Flow velocity (m/s) is determined using the Continuity equation

$$Q = 0.001 V \times A$$

**Where:**

Q is the volumetric flowrate (L/s)  
 V is the flow velocity (m/s)  
 A is the hydraulic cross sectional area  $A = 0.25 \times \pi \times (\text{inner diameter})^2$   
 A is in mm<sup>2</sup>

# CALCULATION PROCEDURE

## (EXCEPT FROM DIN 1988/3)

### 1. Determine the design flow rate and pressure for all the draw off fitting:

The design flow rate  $V_R$  is derived from the draw-off fitting flow rate. The table below gives guideline values for the design flow rate common types of fittings and appliances, the design flow rate  $V_R$  may be determined as a mean value using the following equation.

### 2. Determine total flow rate and assign to pipe runs

The design flow rates for all draw-off points shall be added, starting at the draw-off point furthest from the water main and ending at the water main, and the total flow rates so obtained assigned to the pipe runs considered, each run extending from the fitting where the total flow rate or pipe diameter changes until the next fitting. At the junction of the cold water pipe feeding the water heater with the pipe that branches off, the total flow rate comprises that of the cold and hot water side.

### 3. Use of total flow rate / peak flow rate

The design flow rate of all draw-off points shall be included in the design of water supply system, adding the flow rate of the draw-off points for which continuous use is to be assumed to the peak flow rate of the other draw-off points (continuous use being defined as use lasting more than 15 minutes). Assumptions regarding simultaneous demand are to be based on the type building or its occupation (e.g. residential building or communal facility). Normally, it may be assumed that not all draw-off fitting are fully open at the same time.

### 4. Determination of pipe diameter

Determine the pipe size, pressure loss and flow velocity

### 5. Evaluation of head loss in terms of available pressure

The head loss shall be almost equal to but not greater than the available total head loss.

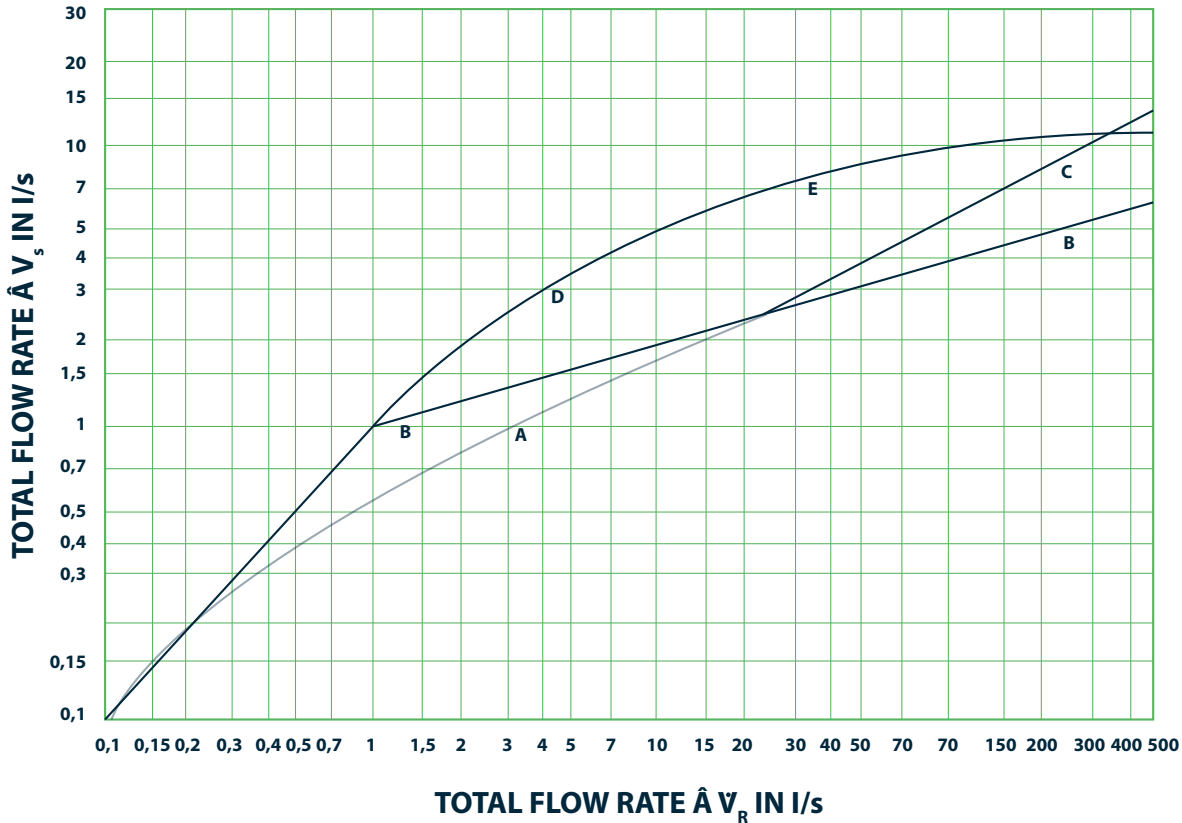
### MINIMUM FLOW PRESSURE & DESIGN FLOW RATE FOR TYPICAL DRAW-OFF POINTS & APPLIANCES

MINIMUM FLOW PRESSURE $P_{min FL}$	TYPE OF DRAW-OFF FITTING APPLIANCE	DESIGN FLOW RATE, $V_R$ , IN 1/S			
		MIXED WATER*		COLD OR HOT WATER	
		$V_R$ COLD WATER 1/s	$V_R$ HOT WATER 1/s	COLD WATER $V_R$ 1/s	(HOT WATER) $V_R$ 1/s
1.0	Taps with jet regulator	DN 10	-	-	0.15
1.0		DN 15	-	-	0.15
1.0	Shower heads	DN 15	0.10	0.10	0.20
1.0	Flushing valves for urinals	DN 15	-	-	0.30
1.0	Domestic dishwasher	DN 15	-	-	0.15
1.0	Domestic washing machine	DN 15	-	-	0.25
1.0	<b>Mixing Valves for:</b>				
1.0	Shower heads	DN 15	0.15	0.15	-
1.0	Baths	DN 15	0.15	0.15	-
1.0	Kitchen sinks	DN 15	0.07	0.07	-
1.0	Wash basins	DN 15	0.07	0.07	-
1.0	Sitz baths	DN 15	0.07	0.07	-
1.0	Mixing valves	DN 20	0.30	0.30	-
0.5	DIN 19 542 flushing cistern	DN 15	-	-	0.13

\* The values specified are based on a temperature of 150C for cold water and 600C for water



# PEAK FLOW RATE V<sub>s</sub>, AS FUNCTION OF TOTAL FLOW RATE, EVA



## CALCULATING THE PEAK FLOW RATE V<sub>s</sub>

	Curve	Application: $\Sigma V_R \leq 20$ l/s Equation	Curve	Application: $\Sigma V_R \leq 20$ l/s Equation
Residential bldgs	A	$V_s: (\Sigma V_R)^{0,45} - 0,14$ in l/s	B	$V_s = 1,7 \cdot (\Sigma V_R)^{0,21} - 0,7$ in l/s
Office buildings	A	$V_s = 0,682 \cdot (\Sigma V_R)^{0,45} - 0,14$ in l/s	C	$V_s = 0,4 \cdot (\Sigma V_R)^{0,54} - 0,48$ in l/s
School building	D	$V_s = 4,4 \cdot (\Sigma V_R)^{0,27} - 3,41$ in l/s	E	$V_s = 22,5 \cdot (\Sigma V_R)^{0,5} - 11,5$ in l/s

### Residential buildings

An additional wash basin, sitz, bath, WC, urinal and shower (in addition to the bath tub) need not be allowed for in determining the total flow rate if it may be assumed that the level of simultaneous use will not be increased by the use of these appliances. If the system is equipped with draw-off fitting with a design flow rate of more than V<sub>R</sub> 0.5l/s then, where the total flow rate is between 0.5l/s and 1.0 l/s, the peak flow rate shall be deemed to be equal to the total flow rate. If the total flow rate is 1.0 l/s or more curve B shall be used.

### School buildings

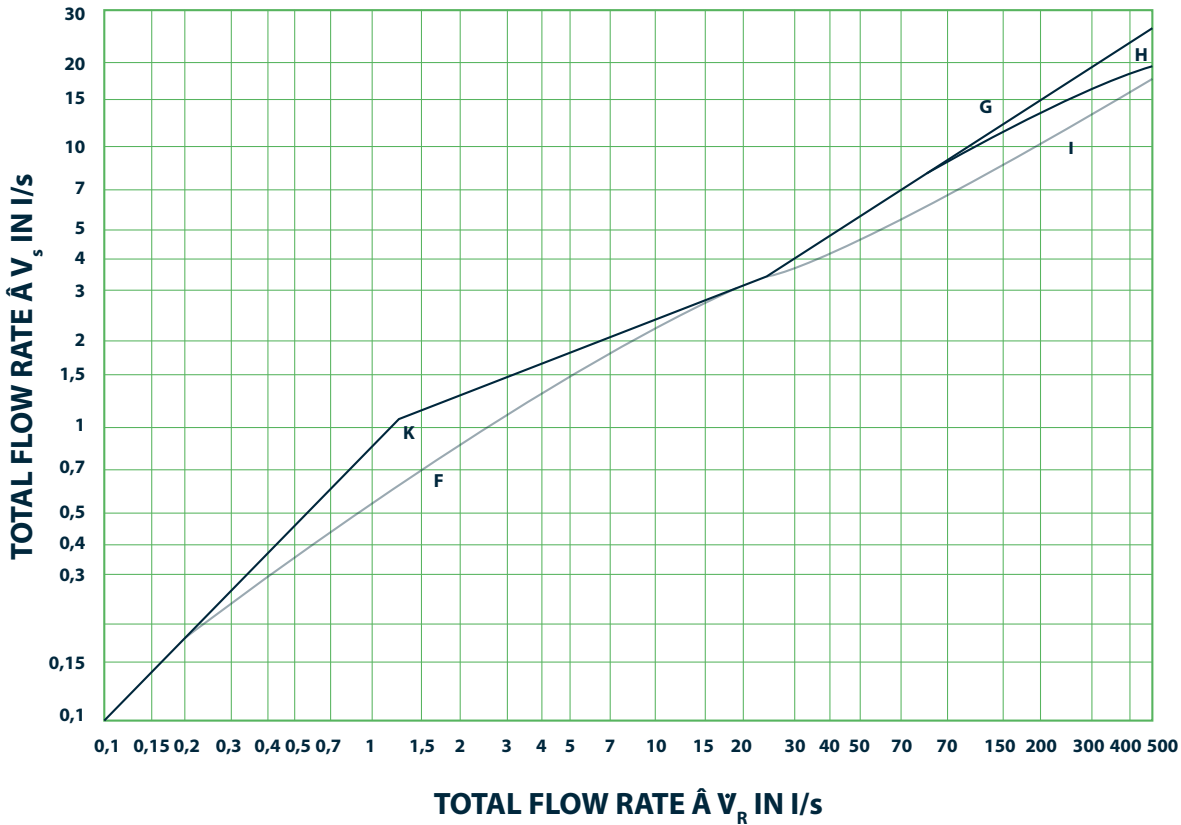
The peak flow rate is deemed to be equal to the design flow rate where  $\Sigma V_R$  does not exceed 1.5 l/s.

## MAXIMUM DESIGN FLOW VELOCITY FOR A GIVEN PIPE RUN

Type of pipe run	Maximum design flow velocity in m/s, for flow lasting	
	15 min or less	More than 15 min
Service pipes	2	2
Supply mains: pipe runs with low bead loss in-line valves (ie. c less that 2)	5	2
in-line valves with greater loss factor	2.5	2

# PEAK FLOW RATE

$V_s$  AS FUNCTION OF TOTAL FLOW RATE,  $\Sigma V_R$



CALCULATING THE PEAK FLOW RATE  $V_s$

	Curve	Application: $\Sigma V_R \leq 20$ l/s Equation	Curve	Application: $\Sigma V_R \leq 20$ l/s Equation
Hotels	F		G	$V_s = 1,08 \cdot (\Sigma V_R)^{0,5} - 0,83$ in l/s
Department Stores	F	$V_s = 0,698 \cdot (\Sigma V_R)^{0,5} - 0,12$ in l/s	H	$V_s = 4,3 \cdot (\Sigma V_R)^{0,27} - 6,65$ in l/s
Hospital (wards)	F		I	$V_s = 0,25 \cdot (\Sigma V_R)^{0,65} - 1,25$ in l/s

## Hotels, department stores and hospitals

If the system is equipped with draw-off fittings with a design flow rate of more than  $V_R$  0.5 l/s then, where the total flow rate is between 0.5 l/s and 1.0 l/s, the peak flow rate shall be deemed to be equal to the total flow rate. If the total flow rate is 1.0 l/s and 20 l/s curve K (equation:  $V_s = (\Sigma V_R)^{0,366}$  in l/s is used for calculating the flow rate.

## Commercial and trade premises

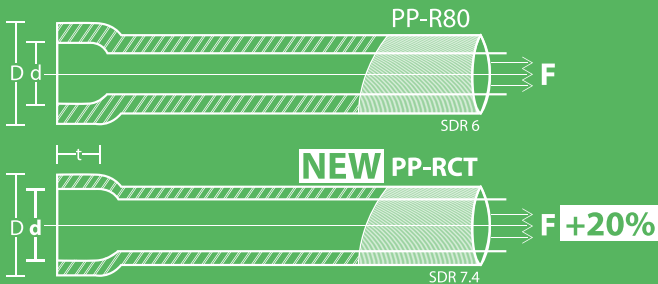
Particular considerations must be given to the extent to which simultaneous demand is to be assumed for water supply system on commercial trade premises. The total flow rate is determined in consultation with the operator of the system.

## Nominal Sizes of main circulating pipes (guidelines values)

NOMINAL SIZE OF HOT WATER PIPES	NOMINAL SIZE OF CIRCULATING PIPE
d 20	d 20
d 25	d 20
d 32	d 20
d 40	d 20
d 50	d 25
d 63	d 32
d 75	d 32

Vertically running pipes shall be at least of size d 20 from their junction with the riser. Horizontal main circulating pipes shall be selected on trial basis as a function of the nominal size or internal diameter of the corresponding hot water pipe.

## BETA-PPR™ – THE NEW PERFORMANCE LEVEL IN POLYPROPYLENE PLUMBING & HEATING SYTEMS



### PRODUCT CHARACTERISTICS

- Standard PP-R SDR 6
- PPR-CT class 5 high heat radiation s 2.5
- PPR-CTclass 2 s 3.2 70°C 50 years

### PP-RCT – TWO INNOVATIVE GRADES

NAME	COLOUR
PP-RCT RA7050	STEEL-GREY (RAL 7042)
PP-RCT RA7050-GN	GREEN (RAL 6024)

## PP-RCT

BRAND NAME

## RA7050

PRIMARY  
DIMENSIONING  
TEMPERATURE

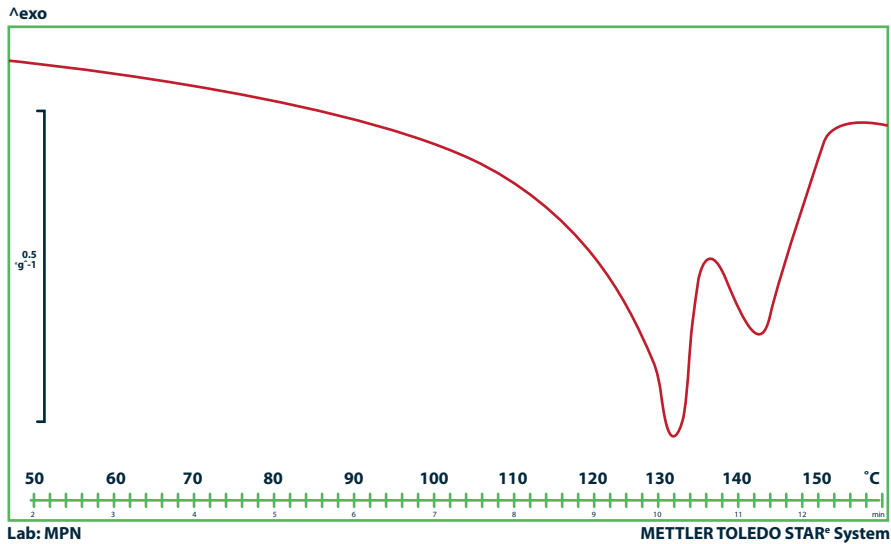
LONG-TERM EXTRAPOLATED STRENGTH  
(=5,0 MPa @ 70°C, 50 years)

## PP-RCT RA7050-GN

GREEN

# TECHNICAL INFORMATION

## WHAT IS PP-RCT ?



- Multiple reactor technology
- State of the art stabilization & additivation
- Special  $\beta$  nucleation

## TYPICAL DSC PLOT OF THE SECOND HEATING CURVE OF BETA-PPR™ RA7050

### PP-RCT Key Innovation Characteristics

**Step change improvement in internal pressure performance & resistance to slow crack growth** compared to existing PP-R materials

**Enhanced long-term durability** due to improved oxidation resistance and excellent resistance to slow crack growth

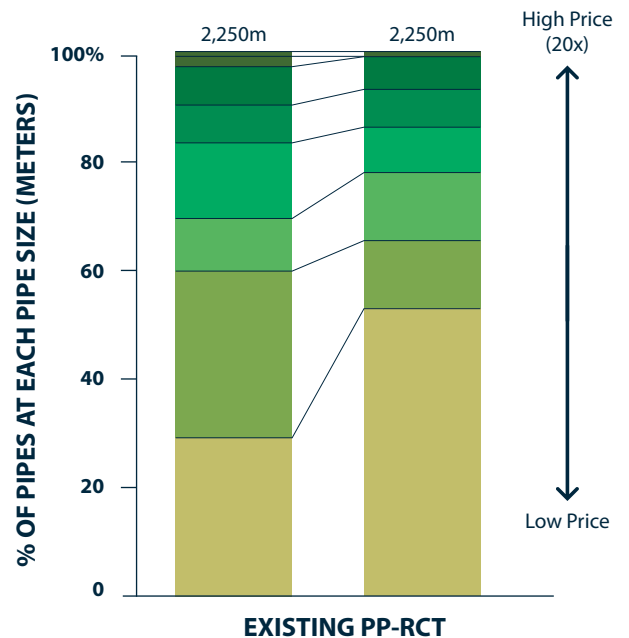
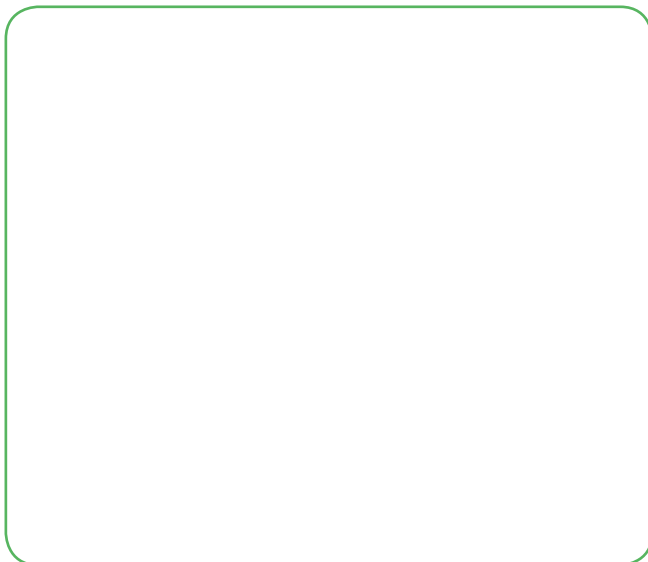
**Excellent impact resistance**

**Very good processing characteristics** (Extrusion and injection molding)

## MECHANICAL PR PARTIES OF PP-RCT RA7050

PROPERTY	RA130E	BETA-PPR™ RA7050
MFR (g/10min)	0,3	0,3
Desnsity (kg/m³)	905	905
Tensile Modulus (MPa)	900	900
Tensile Stree at Yield (MPa)	25	25
Charpy Impact Strength 23°C, notched (kJ/m²)	20	40
0°C, notched (kJ/m²)	3.5	4
-20°C, notched (kJ/m²)	2	2

## ENGINEERING CALCULATIONS DEMONSTRATE THAT PIPES CAN BE DOWNSIZED TO SMALLER CHEAPER SIZES USING PP-RCT



# TECHNICAL INFORMATION

**SPEED UP YOUR LINES WITH PP-RCT™  
STRONGER MATERIAL, THINNER WALLS,  
FASTER LINES**



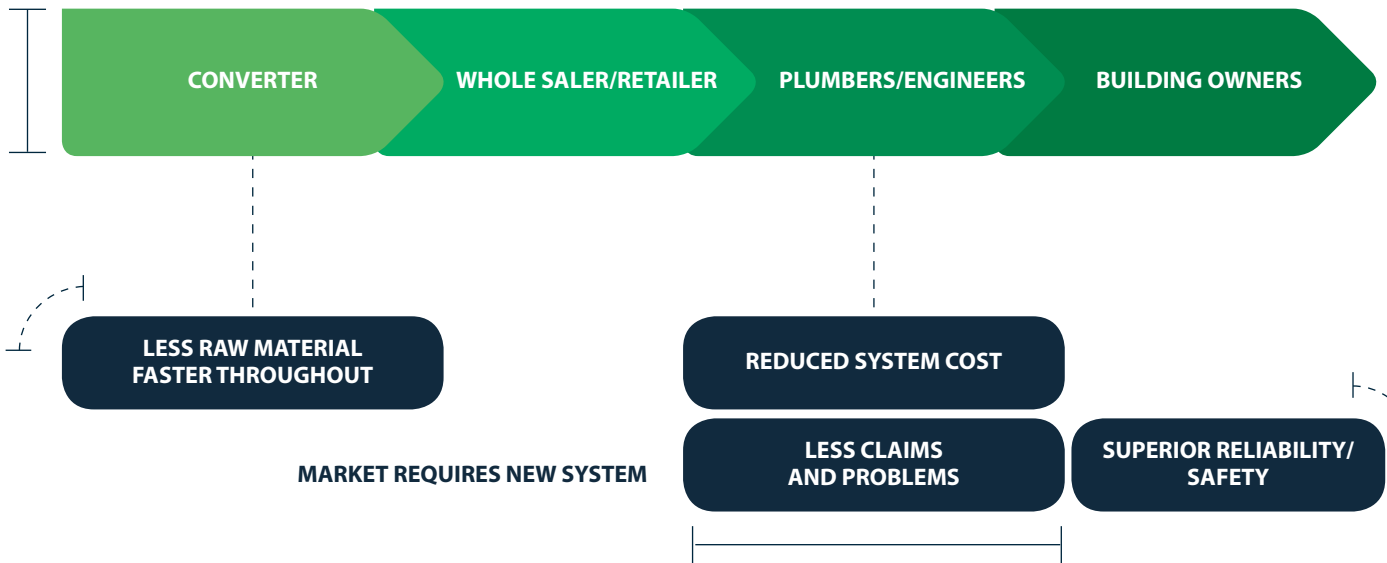
## PP-RCT: Standards , Guidelines, Approvals

It exceeds pressure requirements of EN ISO 15874, DIN 8078 → Pipe approvals with standard PP-R requirements possible ( but no down gauging then)

SKZ – guideline has been prepared ( HR 3.34) ( Testing and Supervisory Guideline Pressure Pipe System made of PP-RCT ), it covers SDR 7.4 pipes ( 70C – 50 years – 10 bar – Sf = 1,5). API is the only company who has been certified according to this guideline up to date.

Borealis is working on international and national standards ( ISO, EN, Din, ets) that cover the improved properties ( long term project).

## PP-RCT WILL PROVIDE BENEFITS THROUGHOUT THE VALUE CHAIN



## PP-RCT The next Generation PP-R for Plumbing & Heating Systems – Conclusions

Biggest innovations since PP-R was introduced more than 20 years ago

PP-RCT is stronger than standard PP-R, which allows:

- Pipe walls to be thinner
- Plumbers to install smaller pipes while maintaining the same water pressure

In addition, PP-RCT pipes will offer enhanced long-term durability, due to better resistance to oxidation and to slow crack growth

# TECHNICAL INFORMATION

## GENERAL

### SCOPE

This specification applies to pressure pipe systems made of polypropylene random copolymer with enhanced crystalline structure and improved temperature resistance (PP-RCT) intended to be used for hot and cold water installations within buildings for the conveyance of drinking water and for heating systems taking into account the permissible operating and the corresponding temperatures according to the application classes of DIN EN ISO 15874-1: 2004-03, table 1. All systems meeting the requirements mentioned there shall also be suitable for the conveyance of cold water of 200C for a period of time of 50 years at an operating of 10 bar.

### PIPES

Depending on dimension group the mean outside diameter  $d_{em}$  of a pipe shall correspond to Table 2.

For any particular application class, operating pressure and nominal size, the minimum wall thickness  $e_{min}$  shall be chosen in such a way that the corresponding pipe series series S or pipe value  $S_{calc}$  is equal to or less than the values of  $S_{calc,max}$  listed in Table 1.

Depending on the dimension group as well as the respective pipe series S or the calculated pipe value  $S_{calc}$ , wall thicknesses  $e_n$  and  $e_{min}$  shall conform to Table 2.

Pipes intended to be joined by welding by welding shall have thickness of 2.0 mm.

Tolerances for the wall thickness e shall conform to Table 3.

**TABLE 1 - MAXIMUM CALCULATED PIPE VALUES  $S_{calc,max}$  FOR PP-RCT**

$p_D$ [bar <sup>1)</sup> ]	APPLICATION CLASS			
	Class 1	Class 2	Class 4	Class 5
	$S_{calc,max}$ - values <sup>2)</sup>			
4	8.23	8.23	8.23	7.3
6	6.1	5.7	6.1	4.8
8	4.5	4.3	4.5	3.6
10	3.6	3.4	3.7	2.9

<sup>1)</sup> 1 bar = 10<sup>5</sup> N/mm<sup>2</sup>

<sup>2)</sup> Values are rounded to 1<sup>st</sup> decimal.

<sup>3)</sup> based on  $\sigma_{old}/p_D$



**TABLE 2 - Pipe dimensions for dimension class A (mm)**

NOMINAL SIZE DN/OD	NOMINAL OUTSIDE D <sub>n</sub>	MEAN OUTSIDE DIAMETER		PIPES SERIES			
		D <sub>em, min</sub>	D <sub>em, max</sub>	S 5	S 4	S 3,2	S 2,5
				WALL THICKNESSES e <sub>min</sub> and e <sub>n</sub>			
16	16	16.0	16.3	1.8	1.8	2.2	2.7
20	20	20.0	20.3	1.9	2.3	2.8	3.4
25	25	25.0	25.3	2.3	2.8	3.5	4.2
32	32	32.0	32.3	2.9	3.6	4.4	5.4
40	40	40.0	40.4	3.7	4.5	5.5	6.7
50	50	50.0	50.5	4.6	5.6	6.9	8.3
63	63	63.0	63.5	5.8	7.1	8.6	10.5
75	75	75.0	75.7	6.8	8.4	10.3	12.5
90	90	90.0	90.9	8.2	10.1	12.3	15.0
110	110	110.0	111.0	10.0	12.3	15.1	18.3
125	125	125.0	126.2	11.4	14.0	17.1	20.8
140	140	140.0	141.3	12.7	15.7	19.2	23.3
160	160	160.0	161.5	14.6	17.9	21.9	26.6

*(Dimensions according to ISO 4065: 1996, applicable to all application classes)*

# TECHNICAL INFORMATION

## Fitting

The dimensions of fittings intended for socket welding shall conform to Table 4.

**TABLE 4 – Dimensions of socket weld fittings [mm]**

Nominal diameter of the fitting D	Mean inside diameter of socket				Maximum out-of-roundness	Socket depth	Measuring level <sup>1)</sup> of d2
	D1 <sub>min</sub>	D1 <sub>max</sub>	D2 <sub>min</sub>	D2 <sub>max</sub>		L <sub>min</sub>	
16	15.20	15.50	15.10	15.40	0.4	13.3	11.5
20	19.20	19.50	19.00	19.30	0.4	14.5	12.5
25	24.20	24.50	23.95	24.35	0.4	16.0	14.0
32	31.10	31.50	30.95	31.35	0.5	18.1	15.5
40	39.05	39.45	38.85	39.25	0.5	20.5	17.5
50	48.95	49.45	48.75	49.25	0.6	23.5	20.0
63	61.90	62.50	61.65	62.15	0.6	27.5	23.5
75	73.65	74.75	72.45	73.55	1.0	30.0	25.5
90	88.60	89.70	87.30	88.40	1.0	33.0	28.0
110	108.45	109.65	107.00	108.20	1.0	37.0	32.0
125	123.35	124.55	121.80	123.00	1.0	40.0	34.0

<sup>1)</sup> Tolerance of position of measuring level of D2: (+0/-0.5)mm

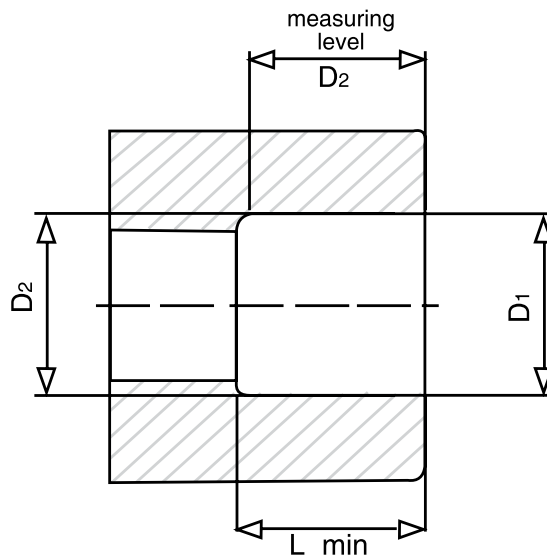


Figure 1 - Dimensions of socket weld fittings

## Material

The material is a polypropylene random copolymer with enhanced crystalline structure and improved temperature resistance (PP-RCT). The long-term resistance (long-term hydrostatic pressure behaviour) shall be tested according to DIN EN ISO 9080: 2003 -10 at 200C, 600C or 700C, 950C and 1100C by an accredited testing institute. The oLPL – values obtained from this evaluation shall conform this evaluation to the corresponding vales of the reference curves shown in figure 2 (the required long-term strength values are presented in Table 5)

**Table 5 – Minimum values of determined long-term hydrostatic strength for the material PP-RCT**

Temperature [°C]	Extrapolation period [a]	Long-term strength [MPa]
20	50	≥11.5
70	50	≥ 5.1
95	4	≥ 3.4

The reference curves in figure 2 in the temperature range from 10 °C to 110 °C are derived from the following equation:

$$\text{Log}(t) = C_1 + C_2 \times \frac{1}{T} + C_3 \times \log(\acute{o}) + C_4 \times \frac{\log(\acute{o})}{T} \quad \text{Equation 1}$$

Using the following values for the individual coefficients:

**Table 6 – Coefficients for equation 1**

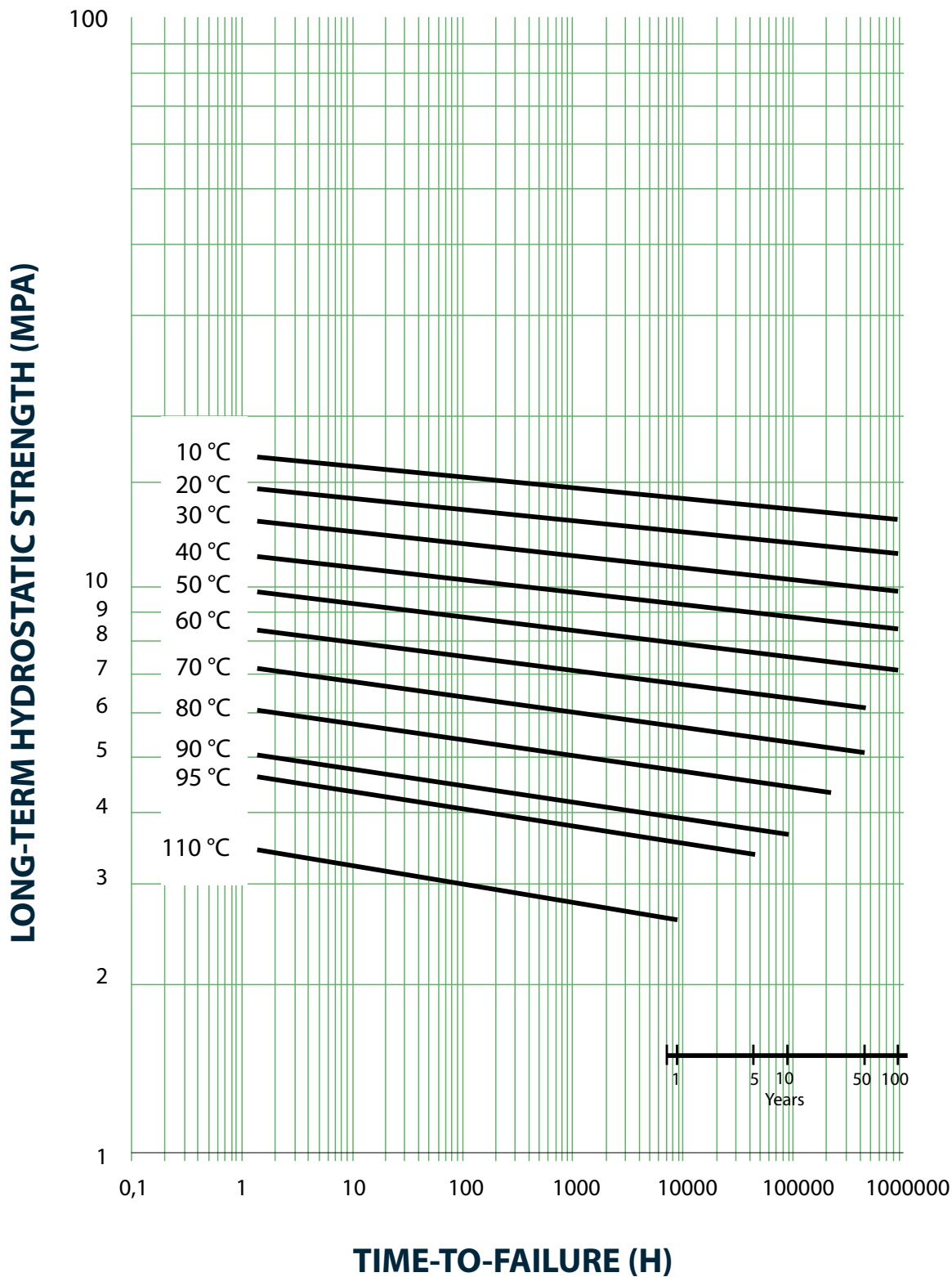
Coefficient	C <sub>1</sub>	C <sub>2</sub>	C <sub>3</sub>	C <sub>4</sub>
Value	-119.546	52176.696	31.279	-23738.797

Pipe and fitting shall be manufactured from virgin or from reworked material, generated from a manufacturer's own production of pipe and fitting. Material from other sources (e.g.: recycled materials) shall not be used. In addition the pipe and fitting manufacturer is not allowed to colour the material by adding a colour master batch.

For application in drinking water the material formulation shall meet the requirements according to the German law for commodity goods as well as the KTW-recommendations. Furthermore the material shall be listed in the latest "DVGW-material list polypropylene for drinking water installation – hygienic test on PP-granules and PP-pipes of raw material manufacturers". Finally the material shall meet the requirements according to the DVGW-work sheet W 270.

# TECHNICAL INFORMATION

## LONG – TERM BEHAVIOUR FOR PP-RCT



Reference curves of the long-term hydrostatic strength of PP-RCT (minimum curves)

## PERMISSIBLE WORKING PRESSURES FOR PP-RCT PIPES TRANSPORTING WATER

TEMPERATURE IN °C		PIPE SERIES S									
	YEARS OF SERVICE	20	16	12.5	8.3	8	5	4	3.2	2.5	2
		STANDARD DIMENSION RATIO SDR									
		41	33	26	17.6	17	11	9	7.4	6	5
ALLOWABLE OPERATING PRESSURE BAR											
10	1	4.7	6.0	7.5	11.4	12.0	19.0	24.0	30.2	38.0	47.9
	5	4.6	5.8	7.3	11.1	11.6	18.4	23.2	29.3	36.9	46.4
	10	4.5	5.7	7.2	10.9	11.5	18.2	22.9	28.9	36.4	45.8
	25	4.5	5.6	7.1	10.7	11.3	17.9	22.5	28.4	35.7	45.0
	50	4.4	5.5	7.0	10.6	11.1	17.7	22.2	28.0	35.3	44.4
	100	4.3	5.5	6.9	10.5	11.0	17.4	21.9	27.6	34.8	43.8
20	1	4.1	5.2	6.6	9.9	10.4	16.6	20.9	26.3	33.1	41.7
	5	4.0	5.0	6.4	9.6	10.1	16.0	20.2	25.4	32.0	40.4
	10	3.9	5.0	6.3	9.5	10.0	15.8	19.9	25.1	31.6	39.8
	25	3.9	4.9	6.1	9.3	9.8	15.5	19.6	24.6	31.0	39.1
	50	3.8	4.8	6.1	9.2	9.6	15.3	19.3	24.3	30.6	38.5
	100	3.8	4.7	6.0	9.1	9.5	15.1	19.0	24.0	30.2	38.0
30	1	3.6	4.5	5.7	8.6	9.0	14.3	18.1	22.7	28.7	36.1
	5	3.4	4.3	5.5	8.3	8.7	13.9	17.4	22.0	27.7	34.9
	10	3.4	4.3	5.4	8.2	8.6	13.6	17.2	21.7	27.3	34.4
	25	3.3	4.2	5.3	8.0	8.4	13.4	16.9	21.2	26.8	33.7
	50	3.3	4.1	5.2	7.9	8.3	13.2	16.6	20.9	26.4	33.2
	100	3.2	4.1	5.1	7.8	8.2	13.0	16.4	20.6	26.0	32.7
40	1	3.1	3.9	4.9	7.4	7.8	12.3	15.5	19.6	24.6	31.0
	5	2.9	3.7	4.7	7.1	7.5	11.9	15.0	18.9	23.8	29.9
	10	2.9	3.7	4.6	7.0	7.4	11.7	14.7	18.6	23.4	29.5
	25	2.8	3.6	4.5	6.9	7.2	11.5	14.4	18.2	22.9	28.9
	50	2.8	3.5	4.5	6.8	7.1	11.3	14.2	17.9	22.6	28.4
	100	2.8	3.5	4.4	6.7	7.0	11.1	14.0	17.6	22.2	28.0
50	1	2.6	3.3	4.2	6.3	6.6	10.5	13.3	16.7	21.0	26.5
	5	2.5	3.2	4.0	6.1	6.4	10.1	12.8	16.1	20.3	25.5
	10	2.5	3.1	3.9	6.0	6.3	10.1	12.6	15.8	19.9	25.1
	25	2.4	3.0	3.8	5.8	6.1	9.7	12.3	15.5	19.5	24.6
	50	2.4	3.0	3.8	5.7	6.0	9.6	12.1	15.2	19.2	24.2
	100	2.3	2.9	3.7	5.7	5.9	9.4	11.9	15.0	18.9	23.8
60	1	2.2	2.8	3.5	5.3	5.6	8.9	11.2	14.2	17.8	22.5
	5	2.1	2.7	3.4	5.1	5.4	8.6	10.8	13.6	17.1	21.6
	10	2.1	2.6	3.3	5.0	5.3	8.4	10.6	13.4	16.8	21.2
	25	2.0	2.6	3.2	4.9	5.2	8.2	10.4	13.1	16.5	20.7
	50	2.0	2.5	3.2	4.8	5.1	8.1	10.2	12.8	16.2	20.4

# TECHNICAL INFORMATION

## PERMISSIBLE WORKING PRESSURES FOR PP-RCT PIPES TRANSPORTING WATER

TEMPERATURE IN °C	YEARS OF SERVICE	PIPE SERIES S									
		20	16	12.5	8.3	8	5	4	3.2	2.5	2
		STANDARD DIMENSION RATIO SDR									
		41	33	26	17.6	17	11	9	7.4	6	5
		ALLOWABLE OPERATING PRESSURE BAR									
70	1	1.8	2.3	3.0	4.5	4.7	7.5	9.4	11.9	15.0	18.9
	5	1.8	2.2	2.8	4.3	4.5	7.2	9.1	11.4	14.4	18.1
	10	1.7	2.2	2.8	4.2	4.4	7.0	8.9	11.2	14.1	17.8
	25	1.7	2.1	2.7	4.1	4.3	6.9	8.7	10.9	13.8	17.4
	50	1.7	2.1	2.7	4.0	4.2	6.8	8.5	10.7	13.5	17.0
80	1	1.5	1.9	2.5	3.7	3.9	6.2	7.9	9.9	12.5	15.8
	5	1.5	1.9	2.3	3.6	3.7	6.0	7.5	9.5	12.0	15.1
	10	1.4	1.8	2.3	3.5	3.7	5.9	7.4	9.3	11.7	14.8
	25	1.4	1.8	2.2	3.4	3.6	5.7	7.2	9.1	11.4	14.4
95	1	1.1	1.4	1.8	2.8	2.9	4.7	5.9	7.4	9.4	11.8
	5	1.1	1.4	1.7	2.6	2.8	4.4	5.6	7.1	8.9	11.2
	(10)*	(1.1)	(1.3)	(1.7)	(2.6)	(2.7)	(4.3)	(5.5)	(6.9)	(8.7)	(11.0)

These pressures do not apply for pipes exposed to U.V radiation Safety Factor (S.F)=1.5

Long - Term Behaviour for PP-RCT

## LONG – TERM BEHAVIOUR FOR PP-RCT PLUMBING & HEATING APPLICATIONS

### PERMISSIBLE OPERATING PRESSURES (SAFETY FACTOR = 1,5)

TEMPERATURE IN °C		PPr-80	PP-RCT SDR11	PP-RCT SDR 7.2	PP-RCT SDR 6
	TIME (YEAR)	SDR 6	ALLOWABLE PREMISSIBLE PRESSURE (BAR)		
20	10	27.4	15.8	25.1	31.6
	25	26.4	15.5	24.6	31
	50	25.7	15.3	24.3	30.6
40	10	19.6	11.7	18.6	23.4
	25	18.8	11.5	18.2	22.9
	50	18.3	11.3	17.9	22.6
60	10	13.9	8.4	13.4	16.8
	25	13.3	8.2	13.1	16.5
	50	12.9	8.1	12.8	16.2
70	10	11.6	7	11.2	14.1
	25	10	6.9	10.9	13.8
	50	8.5	6.8	10.7	13.5
80	10	8.1	5.9	9.3	11.7
	25	6.5	5.7	9.1	11.4
95	5	5.2	4.4	7.1	8.9

# TECHNICAL INFORMATION

## MARKING

Provided that the proof of suitability according to paragraph 4 has been furnished and that inspection is being performed, pipes and fittings meeting the requirements according to paragraph 3 shall be permanently marked in accordance with Table 7 (pipes continuously at a distance of at least 1 m, fittings minimum once per piece).

The producer's logo and the date of production may be encoded, but must be made available in a non-encoded form to the certification body. The manufacturer may add further information at his responsibility on pipes, fittings and other parts.

**TABLE 7 - Marking of pipes and fittings**

Pipes		Fittings	
Information	Example	Information	Example
Manufacturer's logo	XY	Manufacturer's logo	XY
SKZ-mark	.SKZ A XXX	SKZ-mark	SKZ A XXX
Material	PP-RCT	Material	PP-RCT
Date of production (day/month/year)	01/10/05	Date of production (month/year)	f. ex. 05/10 or stamp with date
Dimension	25 x 4.2	Dimension	O 25
Application class	1	Application class <sup>1)</sup>	1
Operating pressure	10 bar	Operating pressure	10 bar

*1) May be marked on packing in case of lack of space*



## REQUIREMENTS AND TESTS FOR SKZ MARK ACCORDING TO DIN EN ISO 15874

### MATERIAL

#### MELT-FLOW RATE (MFR)

<b>Requirement</b>	MFR 230/2. $16 \leq 0.5 \text{ g} / (10 \text{ min})$
<b>Test</b>	According to DIN EN ISO 1133: 2005-09 and proof by inspection certificate 3.1 according to DIN EN 10204

#### MELTING PEAK TEMPERATURES (DSC)

<b>Requirement</b>	C, (for 2nd heating curve) C, (for 2nd heating curve)
<b>Test</b>	According to ISO 11357-3: 1999-03

### PIPES

#### APPEARANCE

<b>Requirement</b>	According to DIN EN ISO 15874-2: 2004-03, par. 5.1
<b>Test</b>	Visually

#### DIMENSIONS

<b>Requirement</b>	According to DIN EN ISO 15874-2: 2004-03, par. 6.1
<b>Test</b>	According to DIN EN ISO 3126: 2005-05

#### LONGITUDINAL REVERSION

<b>Requirement</b>	According to DIN EN ISO 15874-2: 2004-03, par. 8, table 10
<b>Test</b>	According to DIN EN ISO 15874-2: 2004-03, par. 8, table 10

#### HYDROSTATIC PRESSURE TEST

<b>Requirement</b>	During hydrostatic pressure testing under the conditions in Table 8 leakages, cracks or failures shall not occur.
<b>Test</b>	According to ISO 1167: 2003-07

**TABLE 7 - Test conditions for the hydrostatic pressure testing**

Condition	Test temperature [°C]	Hoop stress [N/mm <sup>2</sup> ]	Time-to-failure [h]
A	20	15	≥ 1
B	95	4.0	≥ 165
C	95	3.8	≥ 1,000
D	110	2.6	≥ 8,760

# TECHNICAL INFORMATION

## HOMOGENEITY

### PROCEDURE A

**Requirement** Pigment agglomerations, bubbles, voids and foreign substances shall not be large than 0.02 mm<sup>2</sup>

**Test** A microtome section of approx. 10 µm Thickness shall be removed at right angles to the pipe axis. The microtome section shall be examined as to the type and size of possible inhomogeneities by magnifying the area 75 to 100 times while the total surface shall be at least 100 mm<sup>2</sup>.

### PROCEDURE B

**Requirement** Pigment dispersion ≤ grade 3

**Test** According to ISO 18553: 2002-03

## MELT-FLOW RATE (MFR) COMPARED TO MATERIAL

**Requirement** The MFR of the pipe shall not deviate more than 20% from than of the material

**Test** According to DIN EN ISO 1133: 2005-09

## IMPACT BEHAVIOUR

**PROCEDURE A** For pipe series S 3.2 and S 2.5 with outside diameters ≤ 75 mm

**Requirement** breaking rate ≤ 10% (10 sample) under condition of Table 9

**Test** Adapted to EN 744: 1995-08

**TABLE 9 - Test conditions for impact behaviour**

Pipe ø [mm]	Falling weight type	Mass of falling weight [kg]	Test temperature [°C]	Height [m]
16	d25	0.25	0	0.3
20	d25	0.25	0	0.6
25	d25	0.25	0	1.0
32	d25	0.5	0	0.6
40	d25	0.5	0	0.8
50	d25	0.5	0	1.0
63	d25	0.8	0	0.8
75	d25	0.8	0	1.0

**PROCEDURE B** For all other pipe series with outside diameters ≤ 75mm

**Requirement** breaking rate ≤ 10% (10 sample, test temperature 0 °C)

**Test** According to ISO 9854-1: 1994 as well as ISO 9854-2: 1994  
Testing of pipes with a diameter > 75mm is not required.

## OXYGEN PERMEABILITY (OPTIONAL FOR PIPES INCLUDING OXYGEN BARRIER)

**Requirement** oxygen permeability  $\leq 0.32 \text{ mg} / (\text{m}^2 \times \text{d})$  at 40°C for application class 4 and  $\leq 3.6 \text{ mg} / (\text{m}^2 \times \text{d})$  at 80 °C for application class 5

**Test** According to DIN 53380-3

## FITTINGS

### APPEARANCE

**Requirement** According to DIN EN ISO 15874-3: 2004-03, par. 5.1

**Test** visually

### DIMENSIONS

**Requirement** According to DIN EN ISO 15874-3: 2004-03, par. 6

**Test** According to DIN EN ISO 3126: 2005-05

*Table 10 – Test conditions for the hydrostatic pressure test on fittings*

### HYDROSTATIC PRESSURE TEST

**Requirement** During hydrostatic pressure testing under the conditions in Table 10 leakages, cracks or failures shall not occur.

**Test** According to ISO 1167: 2003-07

**TABLE 10 - Test conditions for the hydrostatic pressure test on fittings**

Condition	Test temperature [°C]	Test pressure pF [bar]	Time-to-failure [h]
A	20	$300 / (2 \times S)$	$\geq 1$
B	95	$80 / (2 \times S)$	$\geq 165$
C	95	$76 / (2 \times S)$	$\geq 1,000$
D	110	$52 / (2 \times S)$	$\geq 8,760$

**pF** Test pressure [bar]

**S** Pipe series =  $(\text{SDR} - 1) / 2$

**SDR** standard dimension ratio of the fitting or the equivalent pipe with respect to the operating pressure

### MELT-FLOW RATE (MFR) COMPARED TO MATERIAL

**Requirement** The MFR of the fitting shall deviate maximum 20% from that of the material

**Test** According to DIN EN ISO 1133: 2005-09

# TECHNICAL INFORMATION

## FITNESS FOR PURPOSE OF THE SYSTEM

### HYDROSTATIC PRESSURE TEST ON PIPE CONNECTIONS

**Requirement** During hydrostatic pressure testing under the conditions in table 10 leakages, cracks or failures shall not occur.

**Test** According to ISO 1167: 2003-07

### THERMAL CYCLING TEST

**Requirement** During the thermal cycling test leakages, cracks or failures shall not occur.

**Test** According to DIN EN ISO 15874-5, par. 4.5

### HYGIENIC AND TOXICOLOGICAL TEST

**Requirement** As far as hygiene and toxicity are concerned the pipes and fittings which shall be put on the German market as drinking water systems have to meet the specifications of the Federal Public Health Office of the Federal Republic of Germany.

In detail, these specifications comprise the proof according to DVGW work sheet w 270 for the material and the KTW recommendations for the pipe and fittings.

In case the pipe and fittings shall be put on foreign markets, the respective regional authority will decide on the requirements to be met will regard to hygiene and toxicity.

In the respective case of application, This proof is a servies to be rendered by the producer.

**Test** The test is performed in accordance with the appropriate valid directives, e.g. DVGW work sheet w 270 and KTW-recommendations of the Federal Public Health Office of the Federal Republic of Germany at 20 °C and 60 °C. In the individual case, tests for the corresponding countries shall be agreed.

## INSPECTION

The conformance with the properties required in paragraph 3 of this specification is ascertained by initial type testing and regularly checked by inspection, consisting of internal production control and a third-party control performed according to the conditions for bearing the SKZ-test mark, sheet A 01.

## FITNESS FOR PURPOSE OF THE SYSTEM

All tests according to Table 11 shall be executed for the initial type test and according to Table 12 in case of a formulation change (type test TT) and the requirements shall be met. In addition a suitable analysis of the material used will be carried out (e.g.: high-temperature viscosity number in conjunction with infrared spectroscopy). This analysis must offer a sufficient identification of the material. The material formulation shall be submitted to the SKZ.

## INTERNAL PRODUCTION CONTROL

### BATCH RELEASE TEST (BRT) AND PROCESS VERIFICATION TEST (PVT) BY MANUFACTURER

The manufacturer is responsible for his production control by executing tests according to the table 11 for each machine and each produced pipe dimension and material formulation. Complete test records shall be issued and kept for a period of 5 years.

If during internal production control the requirements are only partly met or not met at all, a repeat test shall be executed using samples from the same production batch. If test results do not comply with the requirements again, the batch must be rejected. The manufacturer is thus obliged to take necessary measures to remedy this defect immediately.

## THIRD PARTY CONTROL

### AUDIT TEST (AT) EXECUTED BY SKZ

As stipulated in an inspection contract the production plant shall be inspected twice a year. Tests according to table 11 shall be carried out twice a year by SKZ.

### REPEAT TEST

If during the audit test according to par. 4.3.1 not all requirements were met, the SKZ shall carry out an announced repeat test together with an inspection visit within 8 weeks after having received all test results. If the test result is negative this time again, a special test shall be carried out according to par. 4.3.3.

### SPECIAL TEST

If during a repeat test according to par. 4.3.2 not all requirements were met, SKZ shall carry out an announced special test together with an inspection visit within 8 weeks after having received all test results. If the test result is again negative, the SKZ-test mark will be withdrawn.

# TECHNICAL INFORMATION

## EXPLANATIONS

This specification is based on current state-of-the-art knowledge and describes the requirements and tests as well as the inspection of the products. This specification is subject to alterations owing to new findings. Standards with a date of issue shall be used. If a standard is mentioned without a date of issue the latest issue is applicable.

Moreover, the conditions specified in sheet A 01 as well as the provisions in accordance with the control contract apply.

**TABLE 11 - Tests on the material, pipes, fittings and the system**

Test	HR's paragraph	Initial type test (ITT) Frequency per formulation	Audit test (AT) Frequency per formulation	Internal production control (PVT, BRT) Frequency per extruder
Tests on granulate				
Melt-flow rate MFR	3.1.1	X	---	on each raw material delivery
Melting seek temperatures (DSC)	3.1.2?	X	at least twice a year	---
Tests on pipes <sup>1)</sup>				
Marking	2	X	at least twice a year	continuously, records daily
Appearance	3.2.1	X	at least twice a year	continuously, records once every 2 hours
Dimensions	3.2.2	X	at least twice a year	every 2 hours
Longitudinal reversion	3.2.3	X	at least twice a year	once a week
Long-term hydrostatic pressure test	3.2.4	According to conditions A, B C; According to condition D using smallest produced dimension	at least twice a year according to conditions A and C	once a week according to conditions A and B
Homogeneity	3.2.5	?	at least twice a year according to condition B	once a month according to procedure A
Melt-flow rate (MFR)	3.2.6	X	at least twice a year	on each start-up of extruder
Impact behaviour	3.2.7	X	at least twice a year	once a week
Oxygen permeability	3.2.8	if applicable	if applicable at least twice a year	---

**TABLE 11 - Tests on the material, pipes, fittings and the system**

Test	HR's paragraph	Initial type test (ITT) Frequency per formulation	Audit test (AT) Frequency per formulation	Internal production control (PVT, BRT) Frequency per extruder
<b>Tests on fittings <sup>1)</sup></b>				
Marking	2	X	at least twice a year	continuously, records daily
Appearance	3.3.1	X	at least twice a year	continuously, records once every 2 hours
Dimensions	3.3.2	X	at least twice a year	every 2 hours
Hydrostatic pressure test	3.3.3	According to conditions A, B C; According to condition D using smallest produced dimension	at least twice a year according to conditions A and C	once a week according to conditions A and B
Melt-flow rate (MFR)	3.3.4	X	at least twice a year	on each start-up of extruder
<b>Tests on fitness for purpose of the system</b>				
Hydrostatic pressure test	3.4.1	X	---	---
Thermal cycling test	3.4.2	X	---	---
<b>Hygienic and toxicological tests</b>				
Hygiene and toxicology	3.5	if applicable	if applicable at least twice a year	---

*1) Initial type test (ITT) will be performed on 2 dimensions or 2 production batches.*

# TECHNICAL INFORMATION

**TABLE 12 —Type testing (TT) after change of material recipe**

Test	HR's paragraph	Test shall be executed if		Test execution /Test scope
		polymer <sup>1)</sup> was amended	additive <sup>2)</sup> was amended	
<b>Tests on granulate</b>				
Melt-flow rate (MFR)	3.1.1	X	X	1 test per recipe
Melting Peaks of the material	3.1.2	X	X	1 test per recipe
<b>Tests on pipes</b>				
Appearance	3.2.1	X	X	1 dimension per recipe
Dimensions	3.2.2	X	X	1 dimension per recipe
Longitudinal reversion	3.2.3	X	X	1 dimension per recipe
Hydrostatic pressure test	3.2.4	X	X	one dimension according to condition D as well as one test at 95°C at 2 different stresses (longest time-to-failure approx. 2,500 h), while failure points shall be located on or above reference curve (figure 2).
Impact behaviour	3.2.5	X	X	1 dimension per recipe
Melt-flow rate (MFR)	3.2.6	X	X	1 dimension per recipe
Homogeneity	3.2.7	X	X	1 dimension per recipe according to procedure B



**TABLE 12 —Type testing (TT) after change of material recipe**

Test	HR's paragraph	Test shall be executed if		Test execution/Test scope
		polymer <sup>1)</sup> was amended	additive <sup>2)</sup> was amended	
Tests on fitting				
Appearance	3.3.1	X	X	1 dimension per recipe
Dimensions	3.3.2	X	X	1 dimension per recipe
Hydrostatic pressure test	3.3.3	X	X	1 dimension according to conditions A and C; by using smallest dimension according to condition D
Melt-flow rate (MFR)	3.3.4	X	X	1 dimension per recipe

1) Due to change of polymer (change of supplier; change of polymerisation process; change of chemical properties of co-monomer)

2) Due to change of additive (e.g.: pigments antioxidants) package (amount changed by more than 30% in weight of an individual additive change of chemical properties or nature of additive)

# TECHNICAL INFORMATION

## MATERIAL

Derivation of the maximum calculated pipe value  $S_{\text{calc, max}}$

## GENERAL

This annex describes the principles regarding the calculation of the maximum calculated pipe value  $S_{\text{calc, max}}$  and hence of minimum wall thicknesses  $e_{\text{min}}$  of pipes depending on application class according to Table 1 of DIN EN ISO 15874-1: 2004-03 and the applicable permissible operating  $p_D$ .

## DESIGN STRESS

The design stress  $\sigma_D$  for a particular application class is calculated from equation 1 [see page 7] using Miner's rule according to ISO 13760 and taking into account the applicable application class requirements given in Table 1 of DIN EN ISO 15874: 2004-03 and the service coefficients given in Table A.1.

**TABLE A.1 – Overall service (design) coefficients**

Temperature in °C	Overall service (design) coefficient C
$T_D$	1.5
$T_{\text{max}}$	1.3
$T_{\text{mal}}$	1.0
$T_{\text{Kalt}}$	1.4

The resulting design stress  $\sigma_D$  has been calculated for each application class and is given in Table A.2.

**TABLE A.2 – Design stress for PP-RCT**

Application class	Design stress $\sigma_D$ [MPa]
1	3.63
2	3.40
4	3.67
5	2.92
°20 C / 50 years	8.24

## DERIVATION OF MAXIMUM VALUE OF $S_{\text{CALC, MAX}}$

$S_{\text{calc, max}}$  is the smaller value of :

Either  $\frac{\sigma_D}{P_D}$  equation 2

Where :

$\sigma_D$  is the design stress according to Table A.2 [MPa]

$P_D$  is the permissible operating pressure of 4 bar, 6 bar, 8 bar or 10 bar, expressed in [MPa]

OR  $\frac{\sigma_{\text{cold}}}{P_D}$  equation 3

Where :

$\sigma_{\text{cold}}$  is the design stress at 20° C relative to a service life of 50 years [MPa]

$P_D$  is the permissible operating pressure of 10 bar, expressed in [MPa]

The values for  $S_{\text{calc, max}}$  for each application class are shown in Table A.3.

**Table A.3 -  $S_{\text{calc, max}}$  values for PP-RCT**

$P_D$ [bar <sup>1)</sup> ]	APPLICATION CLASS			
	Class 1	Class 2	Class 4	Class 5
	$S_{\text{calc, max}}$ – values <sup>2)</sup>			
4	8.2 <sup>3)</sup>	8.2 <sup>3)</sup>	8.2 <sup>3)</sup>	7.3
6	6.1	5.7	6.1	4.8
8	4.5	4.3	4.5	3.6
10	3.6	3.4	3.7	2.9

<sup>1)</sup> 1 bar = 10<sup>5</sup> n/mm<sup>2</sup>

<sup>2)</sup> Values are rounded to 1<sup>st</sup> decimal

<sup>3)</sup> based on  $\sigma_{\text{cold}} / P_D$

## USE OF $S_{\text{CALC, MAX}}$ TO DETERMINE WALL THICKNESS

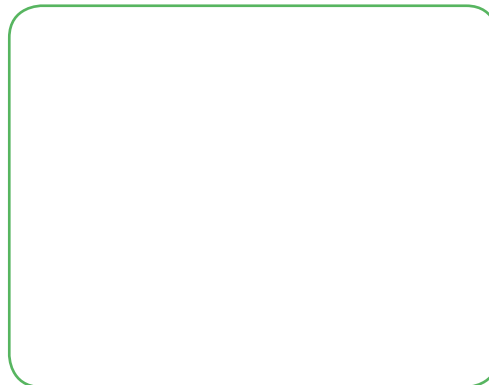
The pipe series S and the calculated pipe value  $S_{\text{calc}}$  shall be selected for each application class and permissible operating pressure from Table 2 in such a way that they do not exceed values for  $S_{\text{calc, max}}$  mentioned in Table A.3.

# TECHNICAL INFORMATION

## DIMENSIONING WITH THE NEW MATERIAL CLASS PP-RCT



## DESIGN PRINCIPLES FOR PLASTIC PIPING SYSTEMS IN PLUMBING & HEATING APPLICATIONS

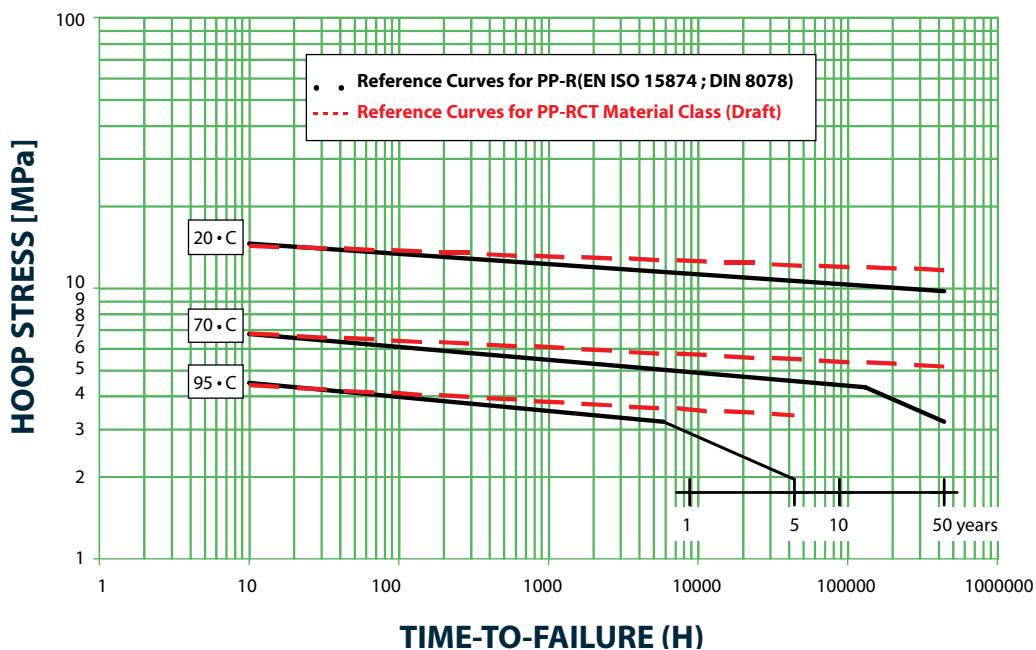


- Design principles for plastic piping system in plumbing & heating applications .
- Pipe design is based on the hydrostatic pressure performance.
- Pipe design takes into account safety factors (overall service design coefficients)
- Pipe design is done for different service conditions (application classes)
- Pipe design is done for different operating pressures

EXPLANATIONS

44

## REFERENCE CURVES OF PP-RCT AND PP-R SCHEMATIC ILLUSTRATION

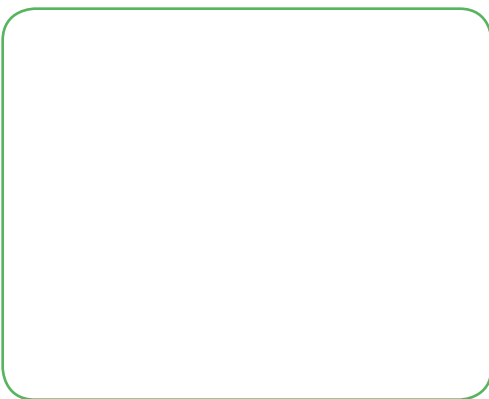


## DESIGN PRINCIPLES FOR PLASTIC PIPING SYSTEMS IN PLUMBING & HEATING APPLICATIONS

### OVERALL SERVICE (DESIGN) COEFFICIENTS (ALSO KNOWN AS SAFETY FACTORS)

Temperature	Overall service (design) coefficient C
$T_{oper}$	1.5
$T_{max}$	1.3
$T_{mal}$	1.0
$T_{cold}$	1.4

### APPLICATION CLASSES ACCORDING TO ISO 15874-1



#### Class 1

- Hot Water Supply 60°C

#### Class 2

- Hot Water Supply 70°C

#### Class 4

- Underfloor Heating and low Temperature Radiators

#### Class 5

- High Temperature Radiators

# TECHNICAL INFORMATION

## DIMENSIONING WITH THE NEW MATERIAL CLASS PP-RCT

Application class	Design Temperature $T_D$ °C	Time <sup>2)</sup> at $T_D$ years	$T_{max}$ °C	Time at $T_{max}$ years	$T_{mal}$ °C	Time at $T_{mal}$ h	Typical field of application
1 <sup>1)</sup>	60	49	80	1	95	100	Hot water supply (60°C)
2 <sup>1)</sup>	70	49	80	1	95	100	Hot water supply (60°C)
4 <sup>2)</sup>	20	2.5	70	2.5	100	100	Underfloor heating and low temperature radiators
	Followed by						
	40	20					
	Followed by						
	60	25	Followed by (see next column)		Followed by (see next column)		
5 <sup>2)</sup>	20	14	90	1	100	100	High temperature radiators
	Followed by						
	60	25					
	Followed by						
	80	10	Followed by (see next column)		Followed by (see next column)		

EXPLANATIONS

46

1) A country may select either class 1 or class 2 to conform to its national regulations.

2) where more than one design temperature appears for any class, the times should be aggregated (e.g. the design temperature profile for 50 years for class 5 is: 20 °C for 14 years followed by 60 °C for 25 years, 80°C for 10 years, 90°C for 1 years and 100°C for 100 h).

**NOTE** For values of  $T_D$ ,  $T_{max}$  and  $T_{mal}$  in excess of those in this table, this standard does not apply

- The design stress for a particular class of service conditions (application class) is calculated from the equation for the reference curves using Miner's rule in accordance with ISO 13760 and taking into account the applicable class requirements and the service coefficient

- The required pipe series for a particular application class is calculated from the design stress and the operating pressure

## DESIGN STRESSES FOR PP-R AND PP-RCT

Application Class	Design Stress [MPa]	
	PP-R	PP-RCT
1	3,09	3,63
2	2,13	3,40
4	3,30	3,67
5	1,90	2,92
20°C/ 50 years	6,93	8,24

## REQUIRED PIPE SERIES FOR PP-R AND PP-RCT FOR APPLICATION CLASS 1 (HOT WATER SUPPLY 60 °C) AND CLASS 2 (HOT WATER SUPPLY 70 °C)

Operating Pressure(bar)	Class 1		Class 2	
	PP-R 80	PP-RCT	PP-R 80	PP-RCT
4	S 5 SDR 11	S 6.3 SDR 13.6	S 5 SDR 11	S 6.3 SDR 13.6
6	S 5 SDR 11	S 5 SDR 11	S 3.2 SDR 7.4	S 5 SDR 11
8	S 3.2 SDR 7.4	S 4 SDR 9	S 2.5 SDR 6	S 4 SDR 9
10	S 2.5 SDR 6	S 3.2 SDR 7.4	S 2 SDR 5	S 3.2 SDR 7.4

## REQUIRED PIPE SERIES FOR PP-R AND PP-RCT FOR APPLICATION CLASS 4 (UNDERFLOOR HEATING & LOW TEMPERATURE RADIATORS) AND CLASS 5 (HIGH TEMPERATURE RADIATORS)

Operating Pressure(bar)	Class 4		Class 5	
	PP-R 80	PP-RCT	PP-R 80	PP-RCT
4	S 5 SDR 11	S 6.3 SDR 13.6	S 3.2 SDR 7.4	S 6.3 SDR 13.6
6	S 5 SDR 11	S 5 SDR 11	S 3.2 SDR 7.4	S 4 SDR 9
8	S 3.2 SDR 7.4	S 4 SDR 9	S 2 SDR 5	S 3.2 SDR 7.4
10	S 3.2 SDR 7.4	S 3.2 SDR 7.4	---	S 2.5 SDR 6

**PP-RCT OFFERS BENEFICIAL PIPE DIMENSIONING FOR COST EFFICIENCY AND OPTIMUM FUNCTIONALITY OF YOUR PLUMBING AND HEATING SYSTEM.**

NOTE:  $\frac{\text{SDR}-1}{2}$

# TECHNICAL INFORMATION

## DIMENSIONING WITH THE NEW MATERIAL CLASS PP-RCT

Application class	Design Temperature $T_D$ °C	Time <sup>2)</sup> at $T_D$ years	$T_{max}$ °C	Time at $T_{max}$ years	$T_{mal}$ °C	Time at $T_{mal}$ h	Typical field of application
1 <sup>1)</sup>	60	49	80	1	95	100	Hot water supply (60°C)
2 <sup>1)</sup>	70	49	80	1	95	100	Hot water supply (60°C)
4 <sup>2)</sup>	20	2.5	70	2.5	100	100	Underfloor heating and low temperature radiators
	Followed by						
	40	20					
	Followed by						
	60	25					
	Followed by (see next column)		Followed by (see next column)				
5 <sup>2)</sup>	20	14	90	1	100	100	High temperature radiators
	Followed by						
	60	25					
	Followed by						
	80	10					
	Followed by (see next column)		Followed by (see next column)				

EXPLANATIONS

48

1) A country may select either class 1 or class 2 to conform to its national regulations.

2) where more than one design temperature appears for any class, the times should be aggregated (e.g. the design temperature profile for 50 years for class 5 is: 20 °C for 14 years followed by 60 °C for 25 years, 80°C for 10 years, 90°C for 1 years and 100°C for 100 h).

**NOTE** For values of  $T_D$ ,  $T_{max}$  and  $T_{mal}$  in excess of those in this table, this standard does not apply

- The design stress for a particular class of service conditions (application class) is calculated from the equation for the reference curves using Miner's rule in accordance with ISO 13760 and taking into account the applicable class requirements and the service coefficient

- The required pipe series for a particular application class is calculated from the design stress and the operating pressure

## DESIGN STRESSES FOR PP-R AND PP-RCT

Application Class	Design Stress [MPa]	
	PP-R	PP-RCT
1	3,09	3,63
2	2,13	3,40
4	3,30	3,67
5	1,90	2,92
20°C/ 50 years	6,93	8,24



## REQUIRED PIPE SERIES FOR PP-R AND PP-RCT FOR APPLICATION CLASS 1 (HOT WATER SUPPLY 60 °C) AND CLASS 2 (HOT WATER SUPPLY 70 °C)

Operating Pressure(bar)	Class 1		Class 2	
	PP-R 80	PP-RCT	PP-R 80	PP-RCT
4	S 5 SDR 11	S 6.3 SDR 13.6	S 5 SDR 11	S 6.3 SDR 13.6
6	S 5 SDR 11	S 5 SDR 11	S 3.2 SDR 7.4	S 5 SDR 11
8	S 3.2 SDR 7.4	S 4 SDR 9	S 2.5 SDR 6	S 4 SDR 9
10	S 2.5 SDR 6	S 3.2 SDR 7.4	S 2 SDR 5	S 3.2 SDR 7.4

## REQUIRED PIPE SERIES FOR PP-R AND PP-RCT FOR APPLICATION CLASS 4 (UNDERFLOOR HEATING & LOW TEMPERATURE RADIATORS) AND CLASS 5 (HIGH TEMPERATURE RADIATORS)

Operating Pressure(bar)	Class 4		Class 5	
	PP-R 80	PP-RCT	PP-R 80	PP-RCT
4	S 5 SDR 11	S 6.3 SDR 13.6	S 3.2 SDR 7.4	S 6.3 SDR 13.6
6	S 5 SDR 11	S 5 SDR 11	S 3.2 SDR 7.4	S 4 SDR 9
8	S 3.2 SDR 7.4	S 4 SDR 9	S 2 SDR 5	S 3.2 SDR 7.4
10	S 3.2 SDR 7.4	S 3.2 SDR 7.4	---	S 2.5 SDR 6

**PP-RCT OFFERS BENEFICIAL PIPE DIMENSIONING FOR COST EFFICIENCY AND OPTIMUM FUNCTIONALITY OF YOUR PLUMBING AND HEATING SYSTEM.**

NOTE:  $\frac{SDR-1}{2}$

# TECHNICAL INFORMATION

## PERMISSIBLE OPERATING PRESSURES (SAFETY FACTOR = 1,5)

TEMPERATURE IN °C		S 4 SDR 9		S 3,2 SDR 7,4		S 2,5 SDR 6		S 2 SDR 5	
	TIME (YEAR)	PP-R	PP-RCT	PP-R	PP-RCT	PP-R	PP-RCT	PP-R	PP-RCT
20	10	17,2	19,9	21,7	25,1	27,4	31,6	34,5	39,8
	25	16,6	19,6	21,0	24,6	26,4	31,0	33,3	39,1
	50	16,2	19,3	20,4	24,3	25,7	30,6	32,4	38,5
40	10	12,3	14,7	15,5	18,6	19,6	23,4	24,7	29,5
	25	11,9	14,4	15,0	18,2	18,8	22,9	23,7	28,9
	50	11,5	14,2	14,5	17,9	18,3	22,6	23,1	28,4
60	10	8,7	10,6	11,0	13,4	13,9	16,8	17,5	21,2
	25	8,4	10,4	10,5	13,1	13,3	16,5	16,7	20,7
	50	8,1	10,2	10,2	12,8	12,9	16,2	16,2	20,4
70	10	7,3	8,9	9,2	11,2	11,6	14,1	14,6	17,8
	25	6,3	8,7	8,0	10,9	10,0	13,8	12,7	17,4
	50	5,3	8,5	6,7	10,7	8,5	13,5	10,7	17,0
80	10	5,1	7,4	6,4	9,3	8,1	11,7	10,2	14,8
	25	4,1	7,2	5,1	9,1	6,5	11,4	8,1	14,4
95	5	3,2	5,6	4,1	7,1	5,2	8,9	6,5	11,3

## PIPE WALL THICKNESS FOR DIFFERENT PIPE SERIES AND SDR

Pipe diameter [mm]	S 4 SDR 9	S 3,2 SDR 7,4	S 2,5 SDR 6	S 2 SDR 5
16	1,8	2,2	2,7	3,3
20	2,3	2,8	3,4	4,1
25	2,8	3,5	4,2	5,1
32	3,6	4,4	5,4	6,5
40	4,5	5,5	6,7	8,1
50	5,6	6,9	8,3	10,1
63	7,1	8,6	10,5	12,7
75	8,4	10,3	12,5	15,1
90	10,1	12,3	15,0	18,1
110	12,3	15,1	18,3	22,1
125	14,0	17,1	20,8	25,1
140	15,7	19,2	23,3	28,1

## INTERPRETATION OF LONG-TERM HYDROSTATIC STRESS APPLICATION

The information presented on this page can be used as a comprehensive overview for the interpretation and use of long term stressing charts for Polypropylene random (type 3) or PP-RCT systems. It is strongly advised that any questions pertaining to these charts be directed to APL's experienced personnel.

### SCOPE

This section provides a definitive method of interpreting long term stressing charts published in EN ISO 15874 and DIN 8077: 2007. This bulletin is strictly confined to the properties of PP-RCT

### HYDROSTATIC STRESS

$$\sigma_D = \frac{\sigma}{C}$$

Then  $\sigma_D$  is used in the following equation to calculate the pressure

$$\sigma_D = p \frac{D-e}{2e}$$

SOLVING FOR PRESSURE

$$p = \frac{2e \sigma_D}{D-e}$$

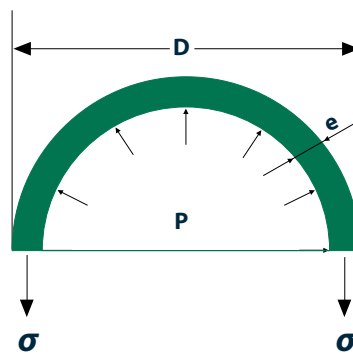
Where P is pressure in MPa (multiply by 10 to get bar), e is thickness of pipe in mm, d is outer diameter of pipe in mm, D is the design stress obtained from the charts in MPa

### EXAMPLE

It is required to know the pressure rating of a 20mm pipe SDR 7.4 for 70°C and 50 years lifetime.

- Diameter is 20mm; D = 20mm
- Thickness is unknown, but we can calculate it from SDR: SDR = D/e then thickness e = D/SDR = 20mm/7.4 = 2.8mm
- From graph on page 28 the 70°C line at 50 years has value = 5 MPa  
 $\sigma_D = \sigma / C = 5/1.5 = 3.3 \text{ MPa}$
- Using the equation presented  
 $P = (2eD)/(D-e)$   
 $P = (2 \times 2.8 \times 3.3)/(20-2.8)$   
 $P = 1.07 \text{ MPa} = 10.7 \text{ Bar}$
- Note that SDR 7.4 withstanding 70

### NOTES



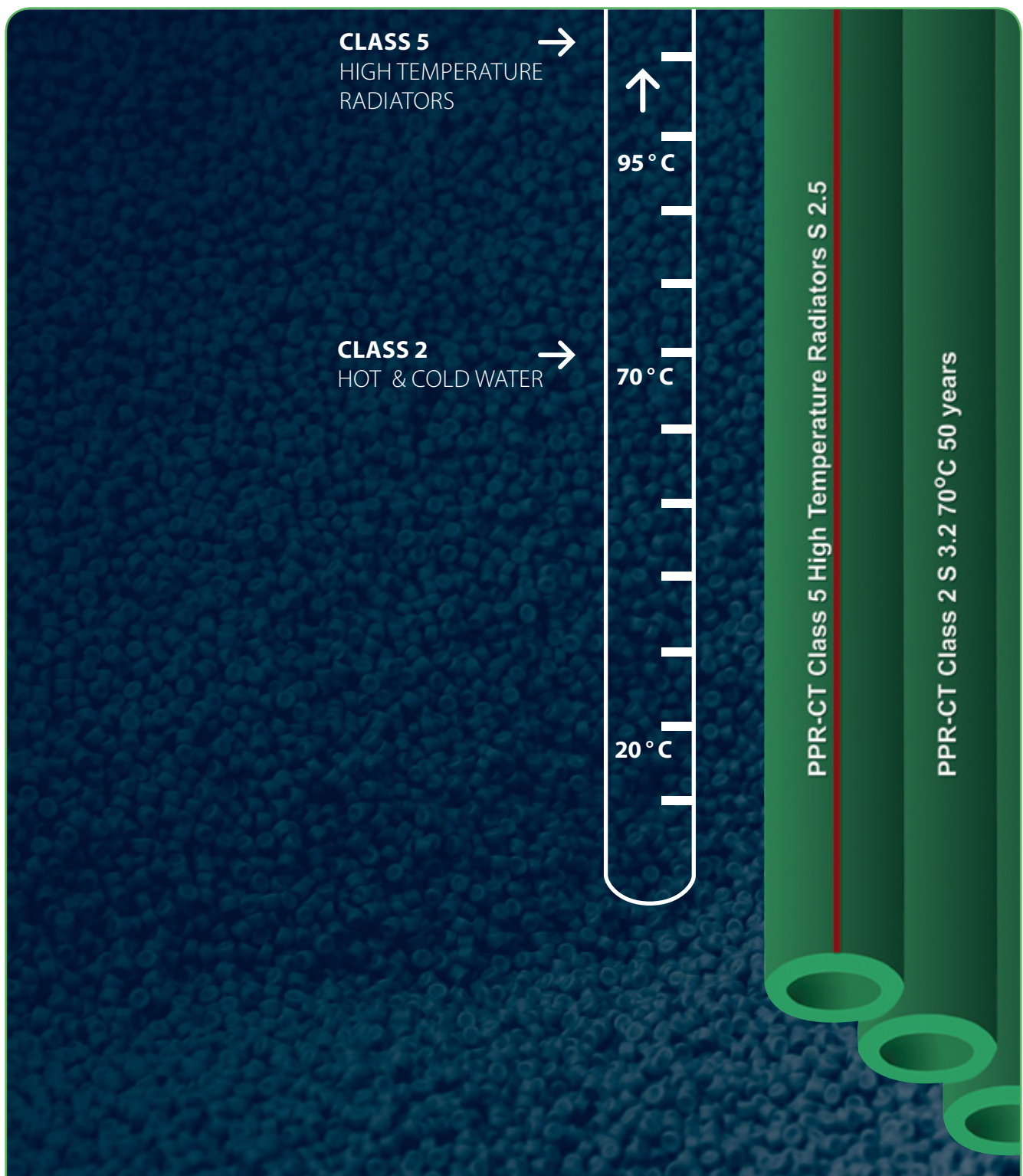
Pipe exposed to internal hydrostatic

# TECHNICAL INFORMATION

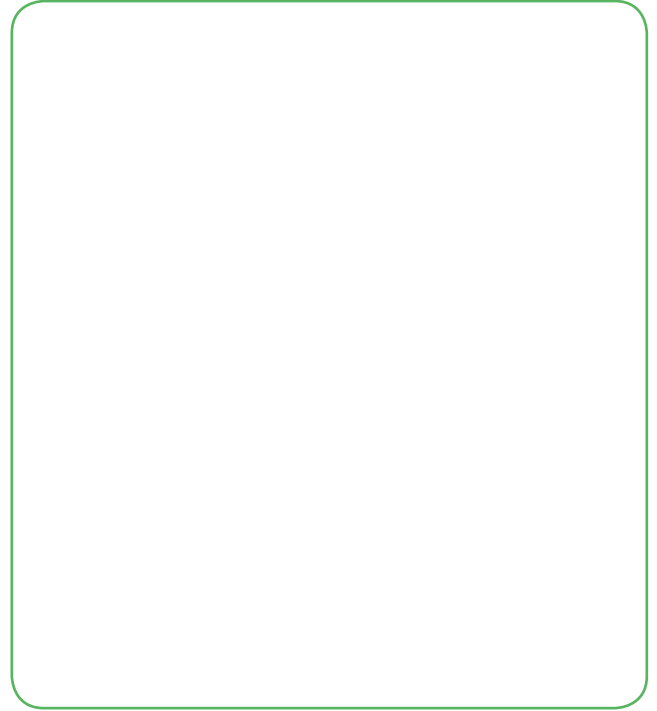
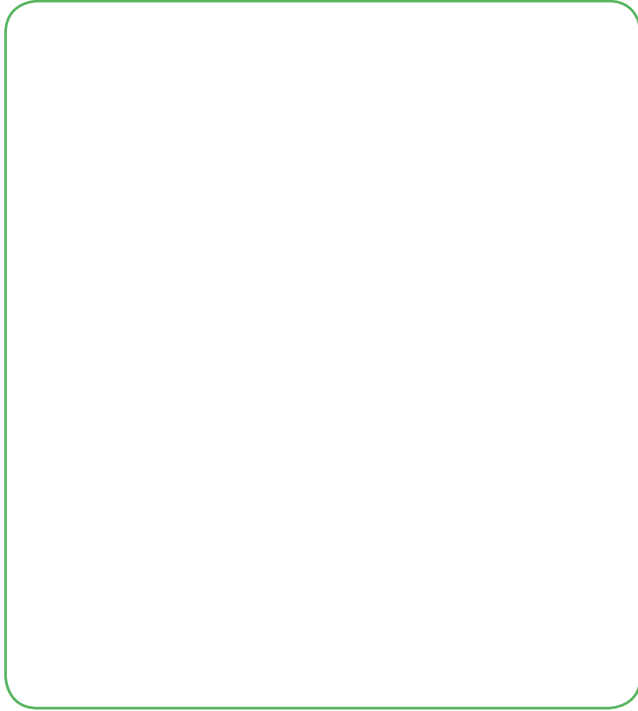
## Beta ( PP-R ) / PP-RCT

### PLUMBING AND HEATING APPLICATION

- New Material class
- Stronger Material , Thinner Wall

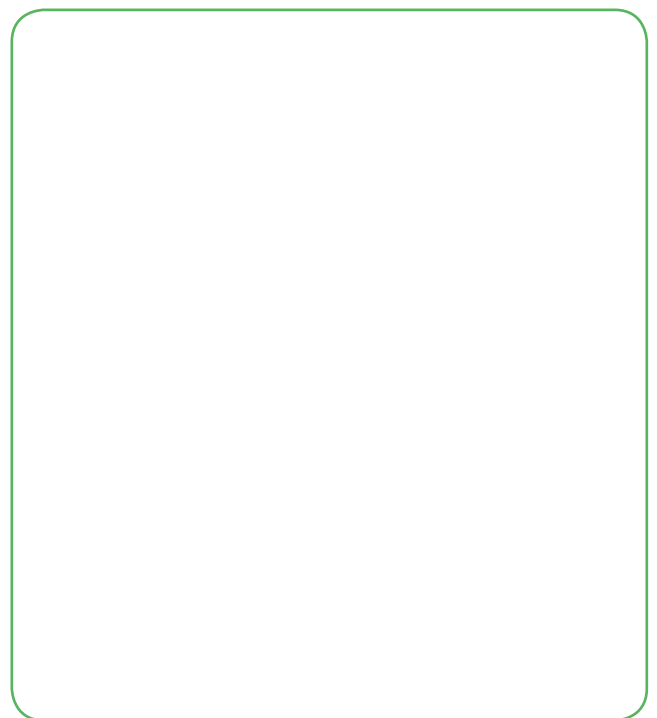
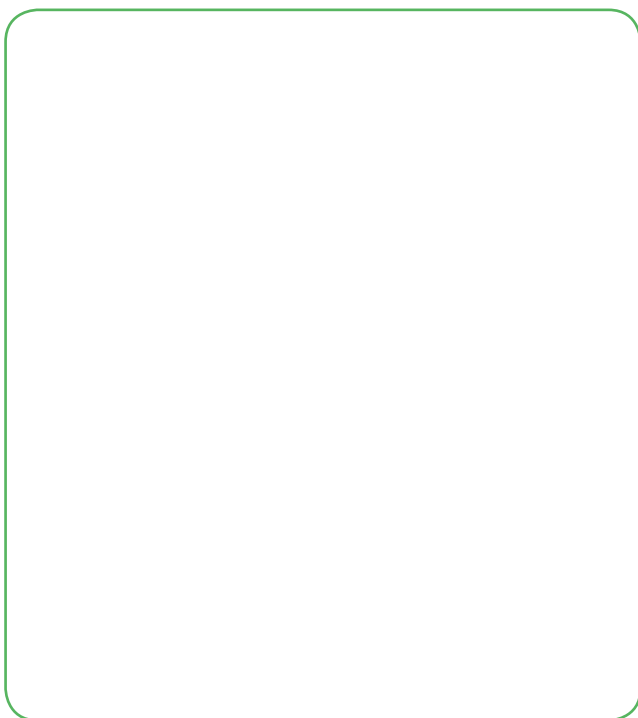


# TECHNICAL INFORMATION



## LABORATORY

API maintains a sophisticated modern laboratory equipped with state of the art. Both incoming and outgoing products are tested to ensure their reliability and compliance with the most demanding national and international standards.



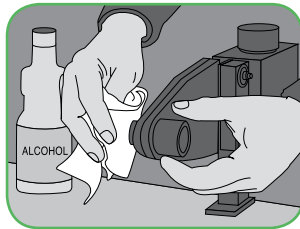
# WELDING

## GUIDELINES FOR PIPE SIZING

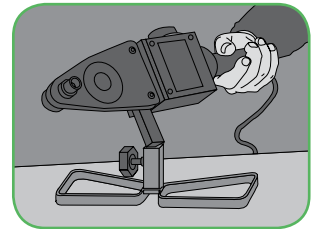
### WELDING PROCEDURES OF APITHERM® PIPES

1-Prior to heating, clean welding sockets with water and alcohol.

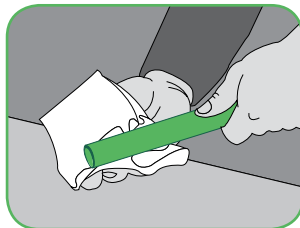
**CAUTION:** Make sure that welding is not plugged in electricity



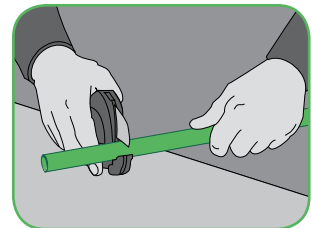
3- Preheat the welding tool to 250°C – 260°C in preparation for the welding procedure



2- Clean Tip of pipe and inside of fitting making sure they are free of foreign substances.



4-Cut the pipe at right / square angle to the pipe axis. Only use pipe cutters with strong sharp blades suitable for cutting PP-RCT plastic pipes.



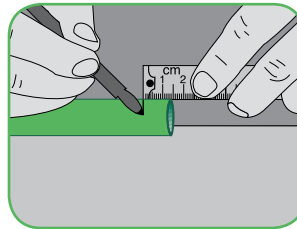
### GENERAL GUIDELINES FOR SOCKET WELDING PP-RCT PIPES AND FITTING.

Pipes external diameter Ø [mm]	Welding depth [mm]	Heating Time sec.	Processing Time sec.	Cooling Time min.
20	14.5	5.0	4.0	2.0
25	16.0	7.0	4.0	2.0
32	18.0	8.0	6.0	4.0
40	20.5	12	6.0	4.0
50	23.5	18	6.0	4.0
63	27.5	24	6.0	6.0
75	31.5	30	8.0	8.0
90	35.5	40	8.0	8.0
110	41.5	50	10	8.0
125	42.0	60	10	8.0

Note: When outdoor temperature reaches below five degrees (5°C) the indicated heating time should be increased by about 50%.

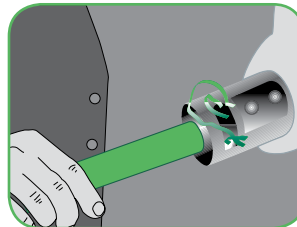
### WELDING PROCEDURES OF APITHERM<sup>®</sup> PIPES

5- Make the welding depth at the end of the pipe with pencil using a template or adhere to the data in the table (see previous page).



Take note of the desired position of the fitting on the pipe using the special indentations on the fitting and lines on the pipe as your rough guidelines.

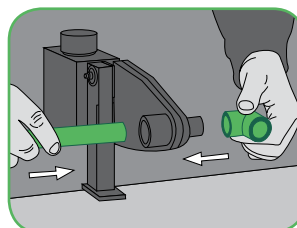
6- It essential to start by making trial peelings to check and confirm the correct setting of the blade. Only utilize original API's peeling tools with undamaged blades. It is necessary to replace dull peeling blades with new ones. ADVISE: Use a space short piece of pipe for carrying out this procedure



Completely peel off the outer layer of aluminum-polypropylene. Push the tip-end of the Alu-pipes into the guide of the peeling tool. Systematically rotate the pipe clockwise, peeling it, until it reaches the stop-end of the peeling tool.

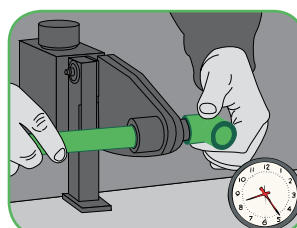
CAUTION: Make sure that the layer of aluminum-PP-r has been completely removed before inserting the peeled pipe into the fusion socket.

7- Push the end of the pipe, without turning/ rotating, up to the marked welding depth into the welding tool. At the same time push the fitting, without turning right down the welding tool. At the same time push the fitting, without turning right down the welding tool. It is essential to strictly observe the mentioned heading times in the previous table.



CAUTION: DO NOT exercise excessive force when working with large sizes. Gradually insert the pipes and fitting into the hot welding socket... For small sizes, it should be reasonably uncomplicated to push the peeling Alu-pipes pipe into the welding socket.

8- the heating time starts, when pipe and fitting have been pushed to the correct welding depth in the welding sockets.

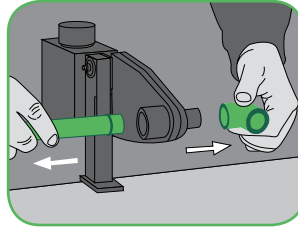


# WELDING

## GUIDELINES FOR PIPE SIZING

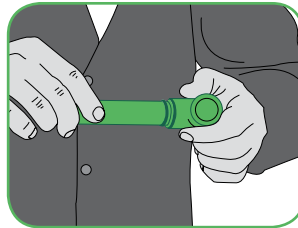
### WELDING PROCEDURES OF APITHERM® PIPES

9- After the stipulated heating time is spent quickly remove pipe and fitting from the welding sockets and Join them instantaneously.



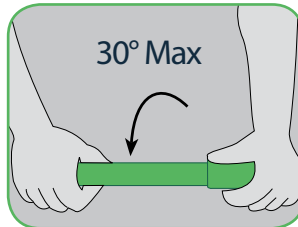
10- Keep pushing the pipe into the fitting until the marked welding depth is covered by a full bead of PP from the weld.

CAUTION: Do not push the pipe too far into the fitting, as this would reduce the bore and in extreme instances close the pipe.

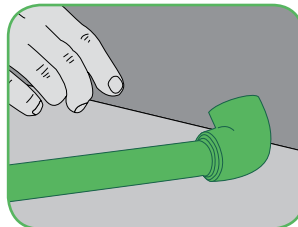


11- The joint components can still be fixed/ rotated during a short period of time (3 to 4 seconds). Strictly adhere to 30 degrees rotating angle in correcting any misalignment in the connection.

CAUTION: Do not attempt to re-align or rotate the connection after the specified time has passed.



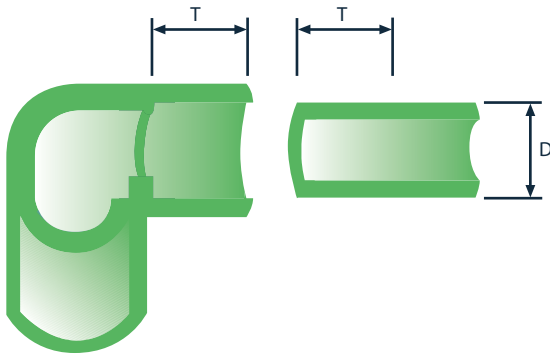
12- After about one hour of cooling the joint between the pipe and fitting becomes fully bundled and ready to use.



Note: When outdoor temperature reaches below five degrees (5°C) the indicated heating time should be increased by about 50%.



### DEPTH DETAIL FOR PP-R WELDING

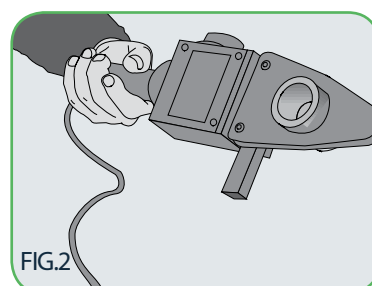
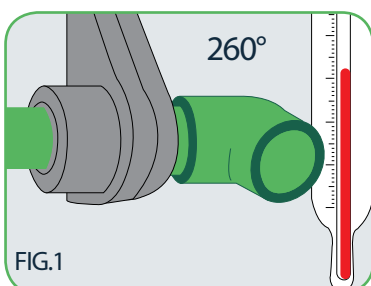


### GENERAL GUIDELINES FOR SOCKET WELDING OF APITHERM<sup>®</sup> PIPES

Pipes external diameter $\varnothing$ [mm]	Welding depth [mm]	Heating Time sec.	Processing Time sec.	Cooling Time min.
20	14.5	5.0	4.0	2.0
25	16.0	7.0	4.0	2.0
32	18.0	8.0	6.0	4.0
40	20.5	12	6.0	4.0
50	23.5	18	6.0	4.0
63	27.5	24	6.0	6.0
75	31.5	30	8.0	8.0
90	35.5	40	8.0	8.0
110	41.5	50	10	8.0
125	42.0	60	10	8.0

The temperature of the welding machine must be monitored continuously.

- **Api** -'s welding machines are electronically controlled and set to operate at 260°C. It is recommended that - **Api** -'s certified welding machines be used when installing an Apitherm<sup>®</sup> system. -api- monitors it's welding machines and services them periodically to assure a long and effective operation. In addition the location of sockets is important to allow for correct heat distribution in the welding machine: a large socket must be located behind a smaller socket as shown in the figure 2 below.



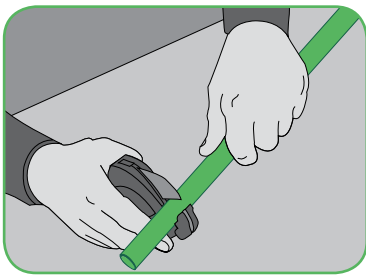
# WELDING

## ELECTROFUSION

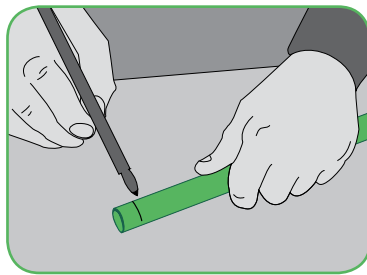
### ELECTROFUSION WELDING

The Apitherm® supplied Electrofusion fitting is the result of the successful adoption of electrofusion technology used with High Density Polyethylene.

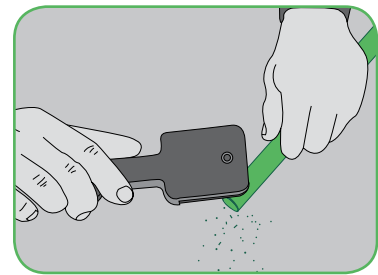
This technology is very straightforward and offers an additional way of practicality to the Apitherm® Sanitary system. The core of this technology is the Electrofusion fitting which consists of a carefully formed copper wire inside a matrix of Polypropylene random. The copper wire is terminated with a copper, the current travelling through the wire cause it to heat up and melt the PP-r at the inner diameter of the fitting. When a pipe is inserted inside the fitting, this melting action is the corner stone of a fusion weld that is as strong as the standard method of fusion welding. The following schematic shows the steps needed to complete an accurate weld:



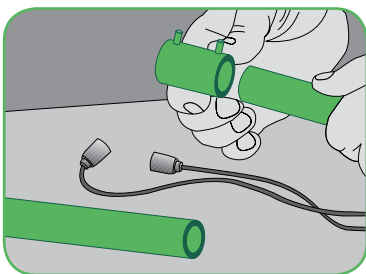
**FIG. 1**  
Make a perpendicular cut at the end of the pipe to be joined.



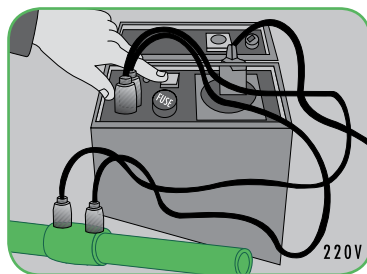
**FIG. 2**  
Measure a distance  $L + 5\text{mm}$  and mark the pipe using a suitable pencil ( $L$  is detailed in the product range for electrofusion fitting).



**FIG. 3**  
Scrap the marked end of the pipe to remove the thin seduction layer using the mark as a stop point. Wipe the scrapped area and the electrofusion fitting with an alcohol stuched paper towel.

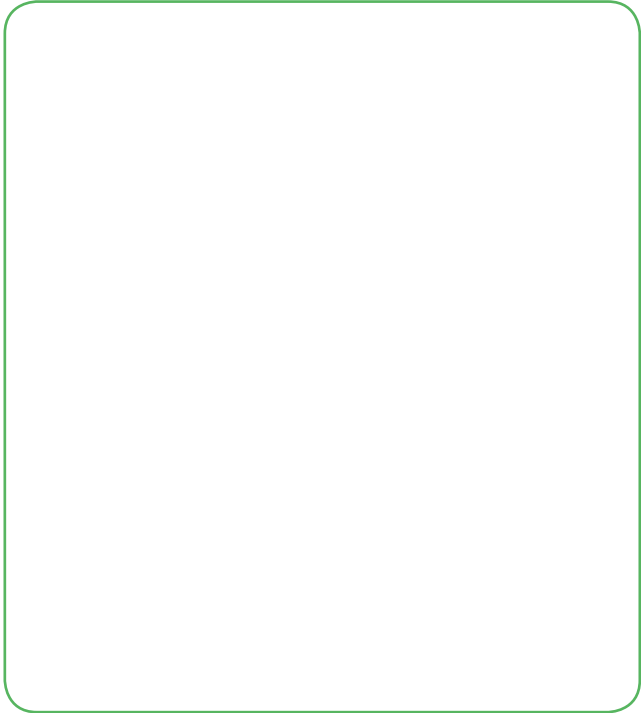


**FIG. 4**  
Insert each pipe in the electrofusion fitting while keeping pipes and fitting in accurate alignment.



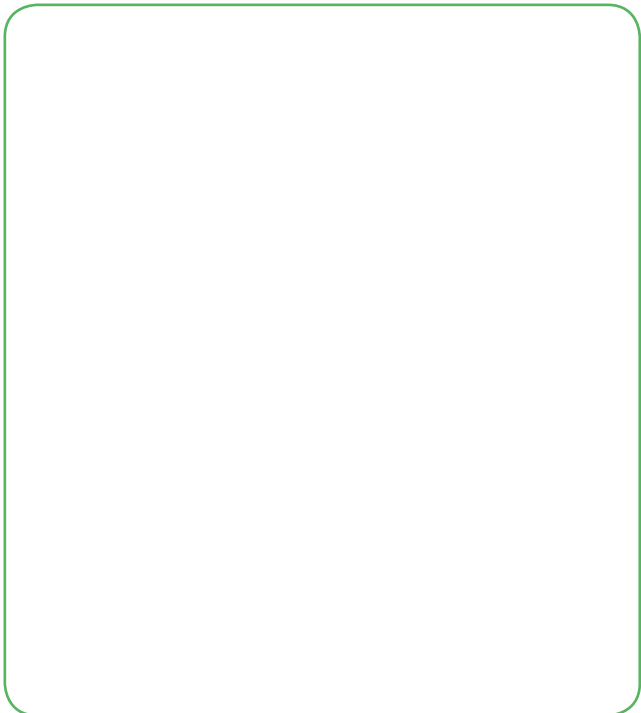
**FIG. 4**  
Attach the welding unit to the upper terminals and proceed with the welding process. During the welding process and the subaccount casting phase do not move or stress any item for at least 4 minutes. After the setting phase, wait two hours to pressure test the system to check its integrity.

# WELDING ELECTROFUSION



**WORKSHOP :**

API has developed a solid and brad extrusion. The company is steadfastly developing its mould production technologies is its highly equipped workshop particularly planned for the production and reparation of its own moulds where it has considerable room for growth in terms of PP-RCT fitting as well as PP fitting for drainage applications.

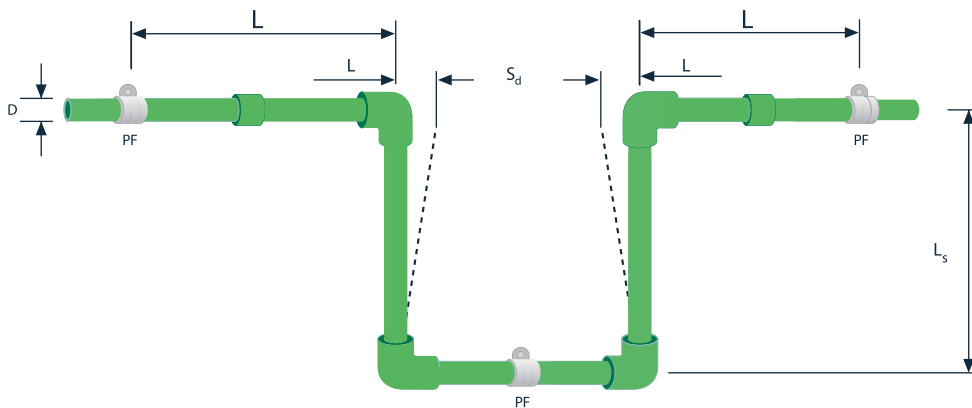


# INSTALLATION

## COMPENSATION FOR LINEAR THERMAL EXPANSION

The high rate of linear expansion compounded with the low E-module of elasticity of the PP-r material translate into a soft and flexible pipe that must be adequately supported and properly restrained to prevent it from excessively snaking or sagging. To compensate for the forces arising from the linear thermal expansion of the PP-r pipe, there must be a good pipe support system with sufficient and stable clamps, supports and mountings. The ideal fastening material for PP-r pipes are rubber lined pipe dampers.

Table below: Determining the distance between horizontal supports for different diameter of ordinary Apitherm® pipes in conjunction with changes of temperature  $\Delta T$  (°C).



### APITHERM® PIPES (PP-RCT)

Table to determine support intervals for APITHERM pipe in conjunction with temperature (°C) and outside diameter

DIFFERENCE IN TEMPERATURE $\Delta T$ °C	PIPE DIAMETER D(MM)											
	16	20	25	32	40	50	63	75	90	110	125	160
	MAXIMUM SUPPORT INTERVALS IN CM											
0	70	85	105	125	140	165	190	205	220	250	280	300
20	50	60	75	90	100	120	140	150	160	180	200	220
30	50	60	75	90	100	120	140	150	160	180	200	220
40	50	60	70	80	90	110	130	140	150	170	180	200
50	50	60	70	80	90	110	130	140	150	170	180	200
60	50	55	65	75	85	100	115	125	140	160	170	180
70	50	50	60	70	80	95	105	115	125	140	150	170

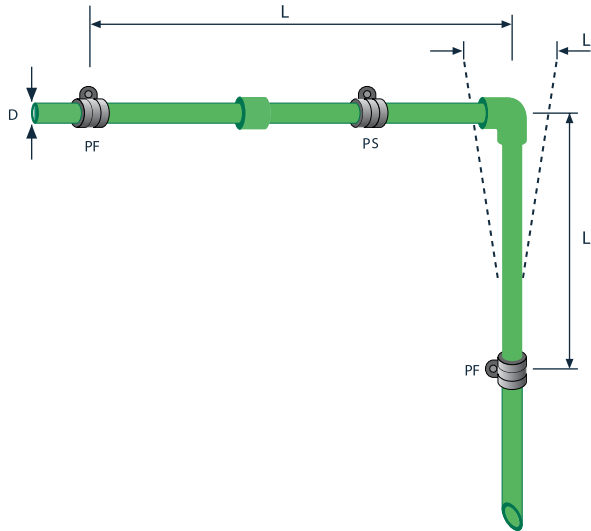
In practice, a good pipe support system together with the turns and bends that are part of running a pipe from one point to another, provide an adequate amount of compensation. However, for straight long runs of pipe, additional compensation is required and must be provided either by using on line Expansion Elbows, Expansion U-Bend or Expansion loops.

**CAUTION:** In extreme cases and in the absence of compensators, the linear expansion of the pipe may stress the fittings to the point of failure.

## COMPENSATION FOR LINEAR THERMAL EXPANSION

**FIG 1: EXPANSION ELBOWS**

- FP = Fixed point
- SP = Sliding point
- L = Pipe length
- $\Delta L$  = Length variation
- $L_s$  = Length of arm



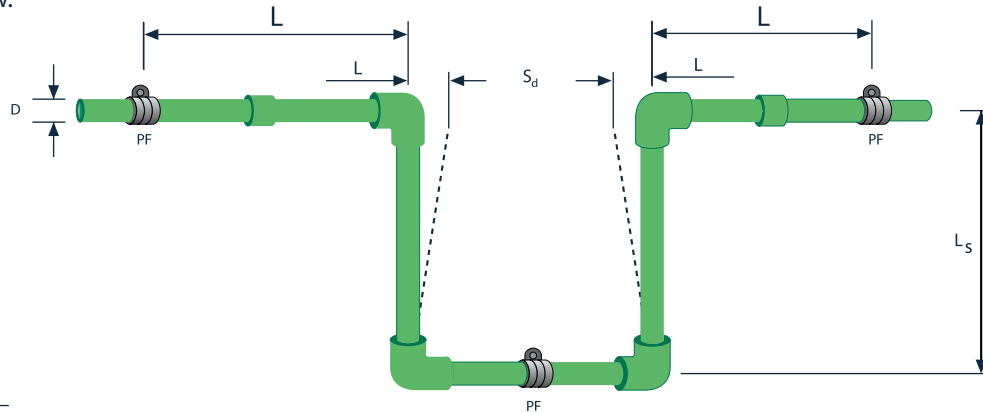
$$L_s = 15 \times \sqrt{D \times \Delta L}$$

\* All units are in mm

**FIG 2: EXPANSION U-BEND**

An expansion U-Bend is equivalent to a double expansion elbow.

- FP = Fixed point
- L = Pipe length
- $\Delta L$  = Length variation
- $S_d$  = Safe distance
- D = Pipe external diameter
- $L_s$  = Length of arm

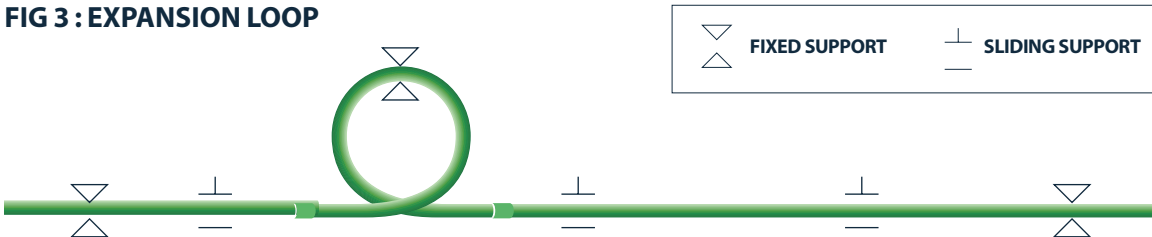


$$L_s = 15 \times \sqrt{\frac{D \times (\Delta L_1 + \Delta L_2)}{2}}$$

\* All units are in mm

It is recommended to observe a safe distance  $S_d$  of 150 mm To 200 mm between the two arms after linear expansion of the connected pipe. Therefore the width between the arms should be equal to:  $S_d + 2 \Delta L$

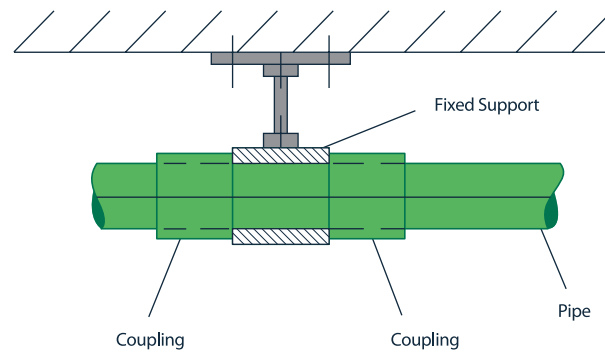
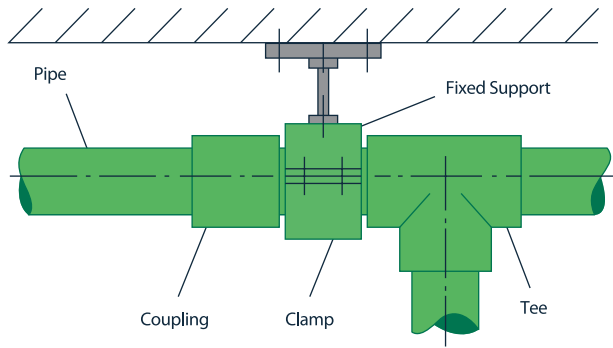
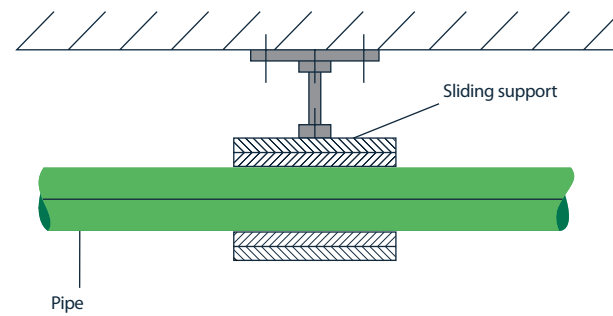
**FIG 3: EXPANSION LOOP**



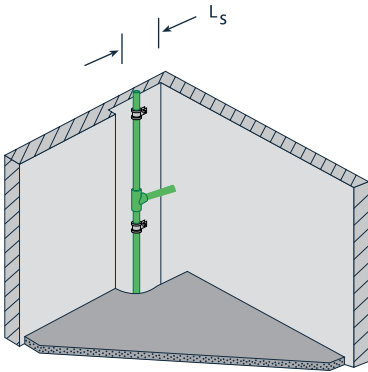
# INSTALLATION

## ANCHORING SUGGESTIONS

The positioning of fixed or sliding supports with respect to Apitherm fitting is of paramount importance. The adjacent figure offer suggestions on arranging anchors and fittings for optimum system performance. A sliding support when used horizontally or vertically must be installed in a section free of fitting in order to allow for easy movement of the pipe without impediments.

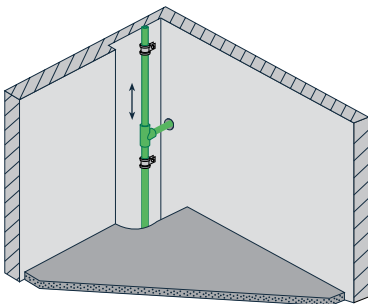


## RISER INSTALLATION

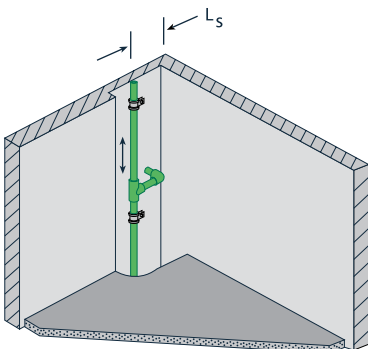


Apitherm® pipes Will give a performance in riser installation when supply pipes out correctly and careful compensation for in consideration. The spacing between fixed support must be kept to a minimum, use the values in table (Spans) as reference values for intial evaluation. The adjacent sketches show different arrangments used during riser installation

When a branch is embedded in concrete, as shown in figure 1. The observance of  $L_s$  is a must to allow for the compensation of the pipe during temperature variation.



If the space whisen the riser limited (figure 2), one method of allowance for compensation is to branch off through a hole that is larger in diameter than the pipe diameter. The diameter of the hole must be determined in such a way as to allow for movemvnt of the arm during expansion of the main pipe. A liner is oflen used during the inplemenlation of this method, to protect the pipe from excessive rubbing against the rough concrete surface if this method is implemented consult with Api- s technical staff for assistance in determining the through hole diameter.



The method show in figure 3 is a take off of the arrangment shown in figure 1. A spring leg is developed to compensats for length variation due to thermal expansion. the effectiveness of the spring leg is the branch pipe to excessive stresses at the entrance point.

### DETERMINATION OF SPANS

The horizontal spacing of fixed clamps depends on the size of the pipe, the requirement to prevent sagging based on the weight of the pipe filled with water and the operating temperature of the system For Apitherm® pipe where no other requirements exist, the recommended maximum spans are as shown in the tables p: 60.

# INSTALLATION

## EXPOSED PIPING INSTALLATIONS

In exposed piping installations, Applications (Alu-pipe) pipes represent the ideal solution to the problems associated with the linear thermal expansion of standard PP-RCT pipes. Apitherm (Alu-pipe) pipes are heat stabilized with a layer of aluminum. As a result, these pipes are sturdy and stable yet light in weight.

When conveying hot water, aluminum stabilized pipes expand linearly boasting a much lower thermal expansion than standard PP-r pipes. The coefficient of linear expansion  $\alpha$ , of the Apitherm (Alu-pipe), is  $3 \times 10^{-5} \text{ K}^{-1} = 0.03 \text{ mm/m } ^\circ\text{C}$  which represents a significant disparity when compared to the  $15 \times 10^{-5} \text{ K}^{-1} \text{ mm/m } ^\circ\text{C}$  coefficient of linear thermal expansion of standard PP-r pipes.

$$\Delta L = \alpha L_o (\Delta T)$$

Where:

$\Delta L$  = amount of expansion in mm

$\alpha$  = coefficient of linear expansion in mm/m  $^\circ\text{C}$

$L_o$  = original of the pipe in m

$\Delta T$  = Difference between ambient temperature and operation temperature in  $^\circ\text{C}$

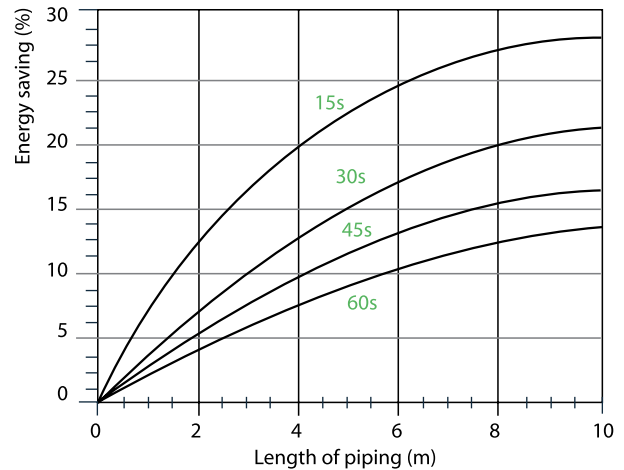


TABLE 1: LINEAR EXPANSION TABLE FOR APITHERM (ALU-PIPE)

$\Delta T (^\circ\text{C})$

Pipe $\phi$ [mm]	10	20	30	40	50	60	70
	LINEAR EXPANSION IN (MM)						
1.0	0.30	0.60	0.90	1.20	1.50	1.80	2.10
1.5	0.45	0.90	1.35	1.80	2.25	2.70	3.15
2.0	0.60	1.20	1.80	2.40	3.00	3.60	4.20
2.5	0.75	1.50	2.25	3.00	3.75	4.50	5.25
3.0	0.90	1.80	2.70	3.60	4.50	5.40	6.30
3.5	1.05	2.10	3.15	4.20	5.25	6.30	7.35
4.0	1.20	2.40	3.60	4.80	6.00	7.20	8.40
4.5	1.35	2.70	4.05	5.40	6.75	8.10	9.45
5.0	1.50	3.00	4.50	6.00	7.50	9.00	11.50
5.5	1.65	3.30	4.95	6.60	8.25	9.90	11.55
6.0	1.80	3.60	5.40	7.20	9.00	10.80	12.60
6.5	1.95	3.90	5.85	7.80	9.75	11.70	13.65
7.0	2.10	4.20	6.30	8.40	10.50	12.60	14.70
7.5	2.25	4.50	6.75	9.00	11.25	13.50	15.75
8.0	2.40	4.80	7.20	9.60	12.00	14.40	16.80



## EXPOSED PIPING INSTALLATIONS

The aluminum layer reduces the linear expansion to up to one fifth (1/5) of that of the ordinary PP-RCT pipes. As a result, the required distance (interval between the supports) is reduced by much as 50%.

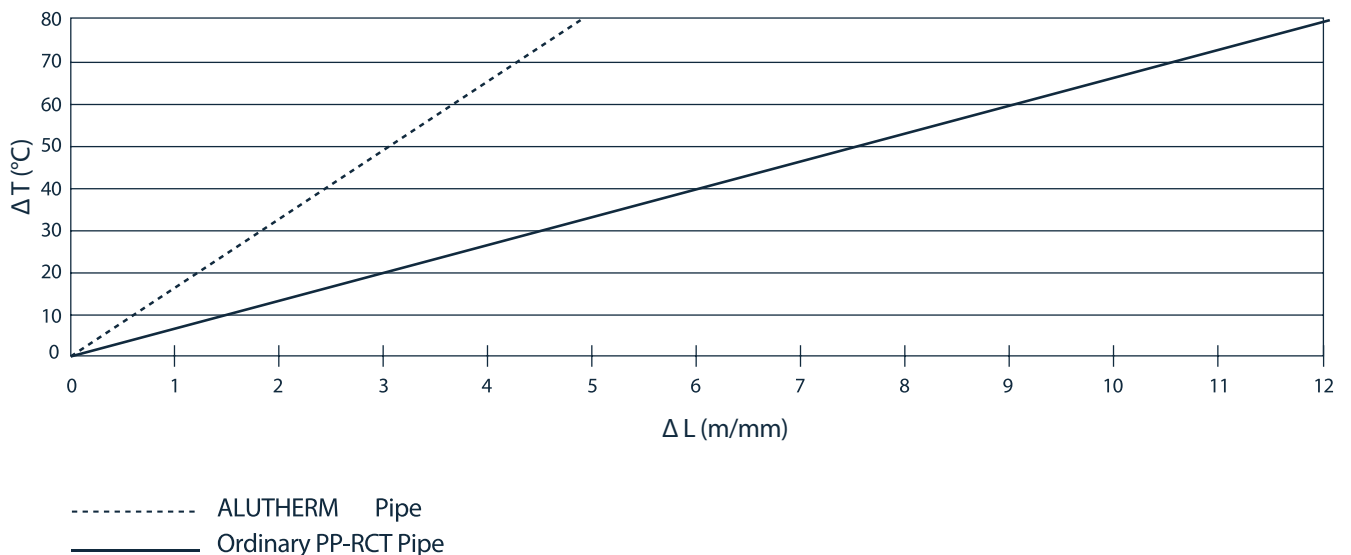
Table 2: Determining the distance between horizontal supports for different diameter of Apitherm (Alu-pipe)<sup>®</sup> pipes in conjunction with changes of temperature  $\Delta T$  (°C).

Difference in Temperature $\Delta T$ (°C).	SUPPORT INTERVALS OF Apitherm (ALU-PIPE) <sup>®</sup>						
	PIPE EXTERNAL $\varnothing$						
	20	25	32	40	50	63	75
SUPPORT INTERVALS IN CM							
0	155	170	195	220	245	270	285
20	120	130	150	170	190	210	220
30	120	130	150	170	190	210	220
40	110	120	140	160	180	200	210
50	110	120	140	160	180	200	210
60	100	110	130	150	170	190	200
70	90	100	120	140	160	180	190

Note: For vertical piping applications, the above support intervals may be increased by a 30% average exceeding the values in this Table.

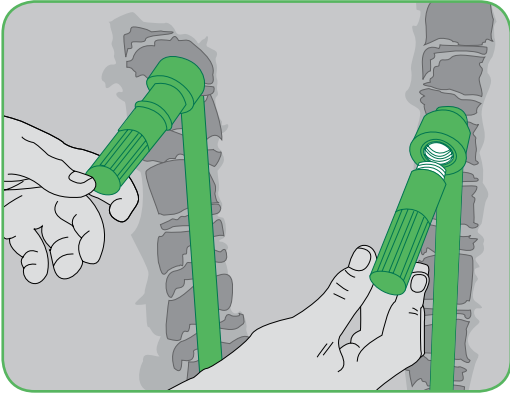
**CAUTION:** Exposed PP-RCT cold water piping needs no compensation.

However, during spells of high heat, the exposed piping (especially in tight shafts) could snake or sag prior to being filled with water. This phenomenon will disappear as soon as pipes are filled with fresh water.

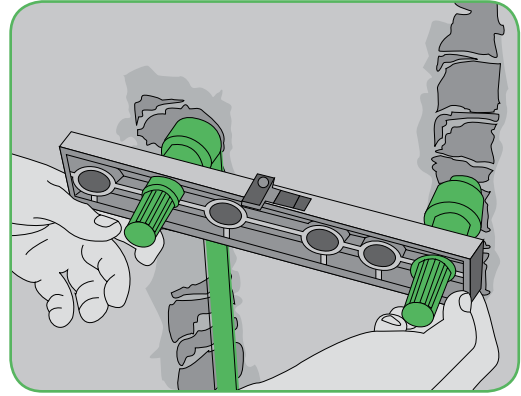


# INSTALLATION

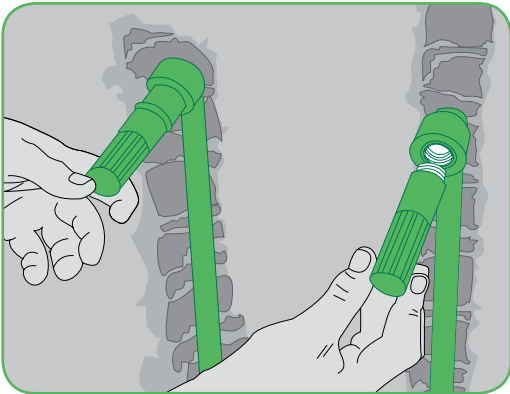
## LEVELLING OF WALL OUTLETS



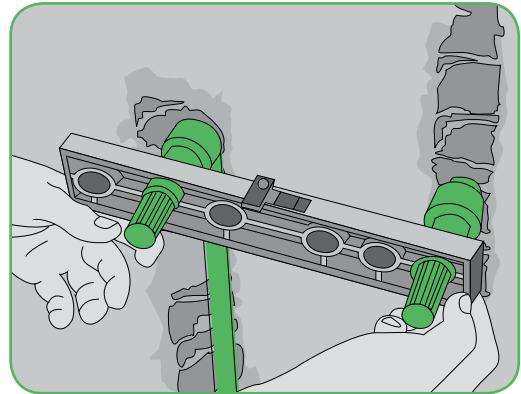
**Fig. 1** screw the leveling knobs on the install fittings as shown.



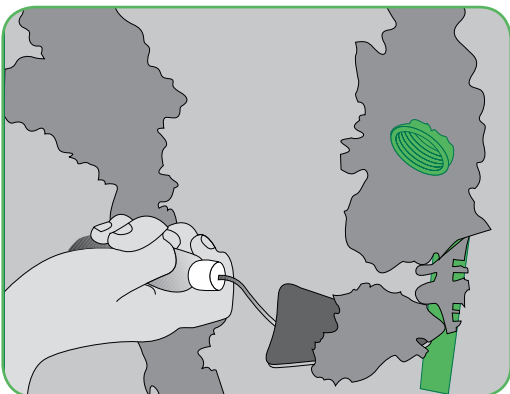
**Fig. 2** slide the special three level instrument over the leveling knobs.



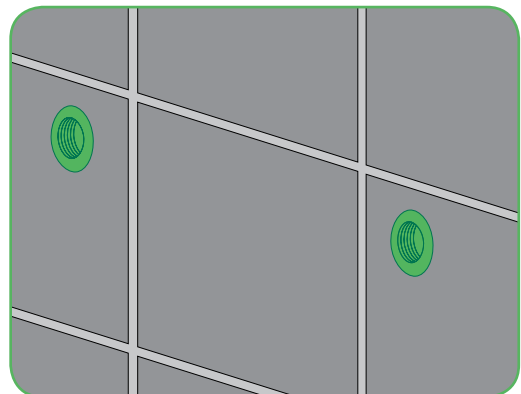
**Fig. 3** Apply quick drying mortar to the back of the fitting to start the leveling operation.



**Fig. 4** push both fittings into the quick drying mortar and level the system using all there levels on the instrument. Hold the leveled system in place for the mortar to dry.



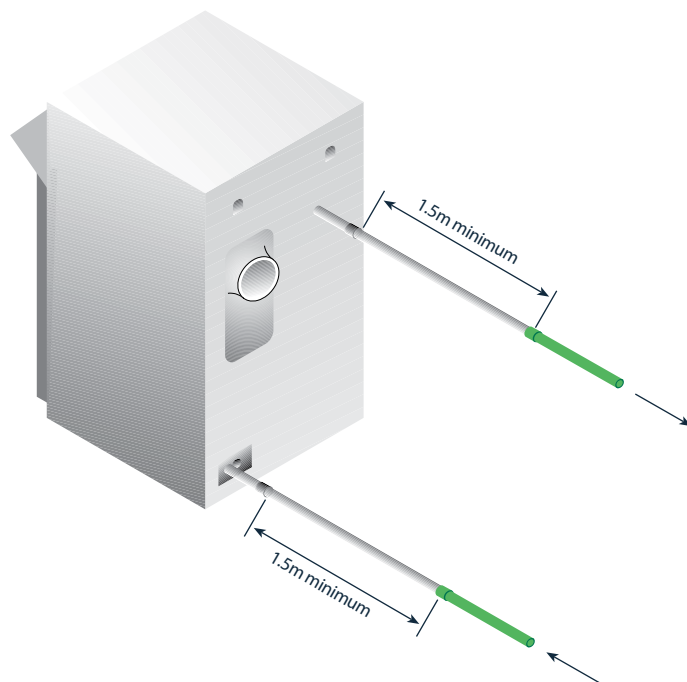
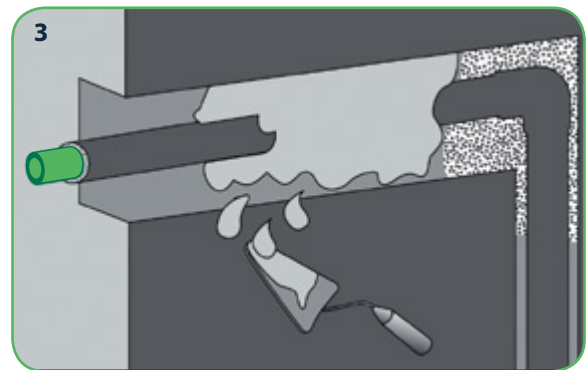
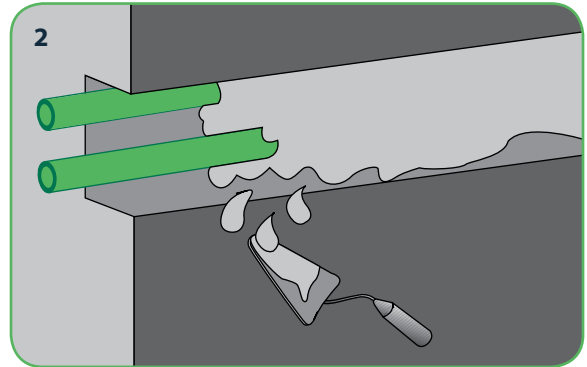
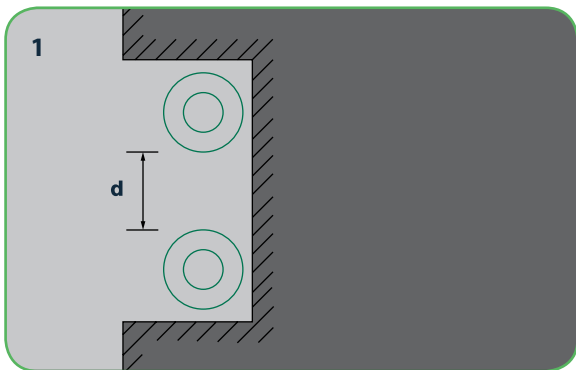
**Fig. 5** Remove the leveling and leveling knobs. Apply regular cement mix to finish the wall.



**Fig. 6** Complete the wall by cementing tiles of the installation. If careful dimensional considerations have been taken. The fittings will be flush with the finished tiled wall.

## WALL EMBEDDING SUGGESTIONS

Due to the excellent chemical resistance of Apitherm pipes, they can come in immediate contact with mortar. Cement or plaster without affecting their performance. No special care is required for thermal expansion in this case. Installation considerations are shown below to achieve a flawless performance: Keep a distance of  $1 \times D$  when installing the pipes in a wall as shown in figure 1. Always lay the hot water supply pipe on top of the cold water supply pipe. At change of direction of insulated pipes, leave enough room to protect the installation with polystyrene or comparable material.



### BOILER INSTALLATIONS

Although Apitherm® pipes are excellent performers when it comes to heating systems, -api- recommends that when connecting to a boiler an allowance of 1.5m between Apitherm® pipe should be observed, galvanized pipe should be used to connect the boiler to the Apitherm® system. The adjacent figure offers a schematic view of this allowance during installation

### EFFECTS OF COPPER

When subjected to length exposure of copper ions at elevated temperatures, polypropylene shows a deterioration of its physical properties. Its properties in applications are not adversely affected by direct contact with brass at temperatures below 60°C however, dezincification resistant brass couplings may be used to connect PP-RCT pipes.

# INSTALLATION

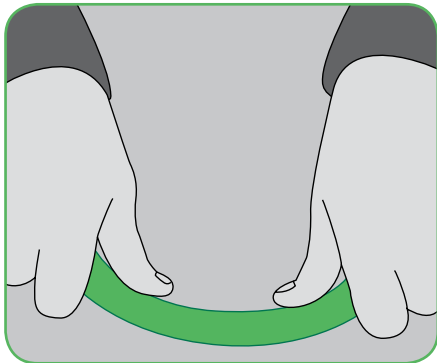
## PIPES FORMING PROCEDURE

The minimum bending radius should be observed according to the table listed below:

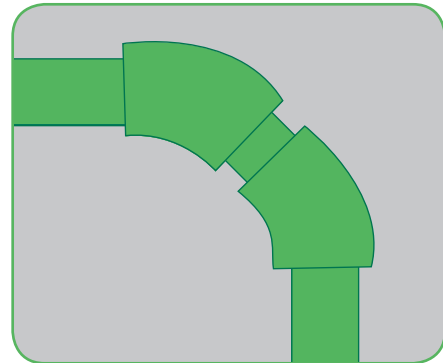
**BENDING RADII**

Diameter of pipe (mm)	Cold bending radius (mm)	Hot bending radius (mm)
20	160	120
25	200	150
32	250	190
40	320	240
50	400	300
63	500	375

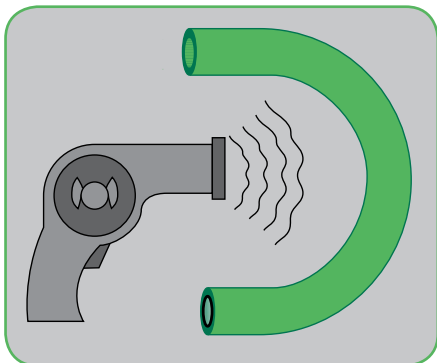
Apitherm® pipes are flexible enough to be formed in cold conditions. When cold forming a pipe observe the radius values shown in the adjacent table. Forming a pipe to these dimensions will keep the integrity of the pipe cross-section. However, if smaller radii are required an industrial heat gun is needed to form the bend. Values for hot forming are listed in the adjacent Table as well.



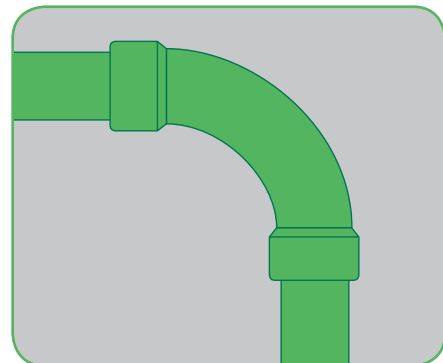
**Fig. 1** Apitherm® pipes can be formed in cold and warm conditions.



**Fig. 3** When trying to form a 90° bend, it is advisable to achieve the 90° bend by using 45° Elbows.

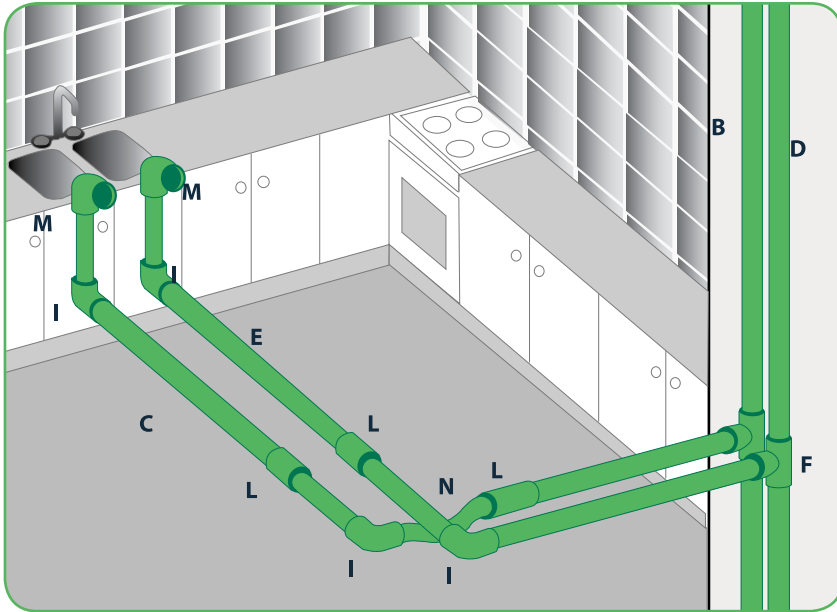


**Fig. 2** When forming a " U " bend as shown in figure 2, an industrial heat gun should be used



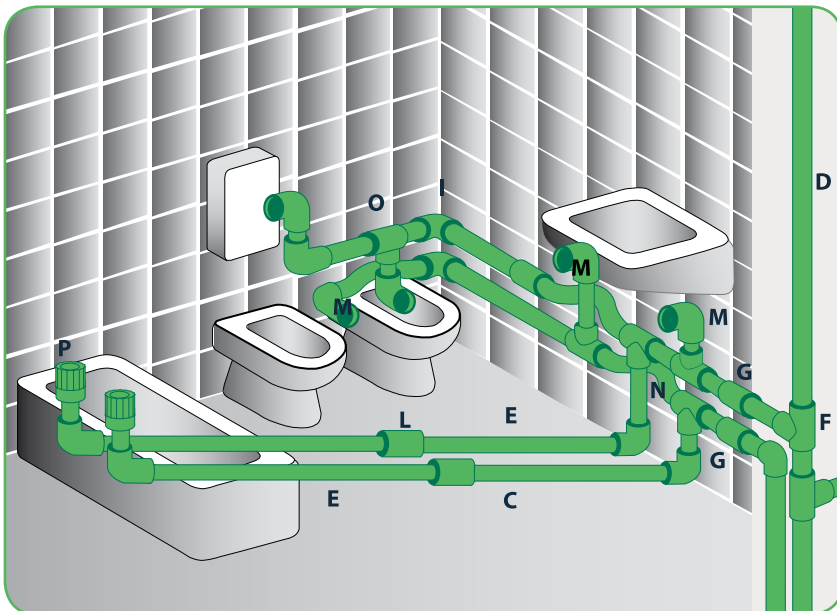
**Fig. 4** \*90° bend are manufactured in 20, 25 and 32 mm diameters.

## MODEL OF INSTALLATION



**Kitchen Installation**

Item	PP-RCT API Code
Item	1205050200 1202050200
B Ø 25 Class 5 Pipe	1202050100
D Ø 25 Class 2 Pipe	1205050100
E Ø 20 Class 2 Pipe C Ø 20 Class 5 Pipe	1215160212
F Reducing tee 25x20x25	1215130100
I 90° elbow Ø20	1215110100
M Female thread 90° elbow Ø20 x 2/1	1225430101
N Overcross Ø20 class 5	1215180100

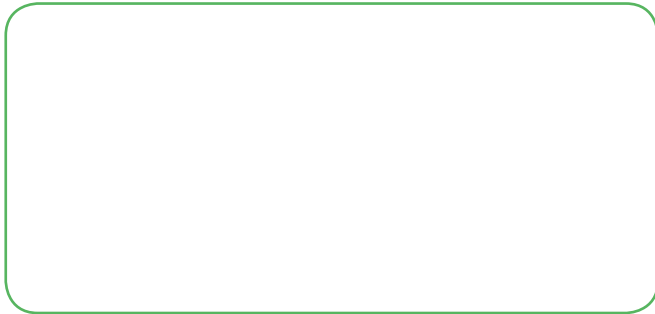


**Bathroom Installation**

Item	PP-RCT API Code
B Ø 25 Class 5 Pipe	1205050200
D Ø 25 Class 2 Pipe	1202050200
E Ø 20 Class 2 Pipe C Ø 20 Class 5 Pipe	1205050100 1202050100
F Reducing tee 25x20x25	1215160212
G stop valve	2412220
I 90° elbow Ø20	1215130100
L coupling Ø20	1215110100
M Female thread 90° elbow Ø20 x 2/1"	1225430101
N Overcross Ø20 Class 5	1215180100
O Tee Ø20	1215150100
P Female thread Adap- tor Ø20 x 2/1"	1225410101

# INSTALLATION

## QUALITY ASSURANCE



Chapy impact tester (load sensor)

The quality system provides our customers with the confidence level required for them to be assured of our ability to meet the required quality level for products and services at a competitive price and on time.

This quality assurance management program and quality system is subject to review and approval by an accredited organization under the ISO 9002 standard.

The quality assurance management program and quality system as implemented in accordance with the following ISO 9000 family of standards and with applicable statutory (requirements of society ) and industry standards.

### References

#### 1. ISO Standards

##### 1.1 ISO 8402 – 1994

Quality vocabulary

##### 1.2 ISO 9000 – 1 Quality Management and Quality Assurance Standards

Guidelines for Selection and Use

##### 1.3 ISO 9002 – Second Edition 1994-07-01

Quality Systems: Model for quality assurance in production, installation and servicing

##### 1.4 ISO 9003 Quality System

QA Final Inspection and Testing

##### 1.5 ISO 9004 – 1

Quality Management and quality System Elements

##### 1.6 ISO 10011 – 1

Guidelines for Auditing Quality Systems

##### 1.7 ISO 10012 – 1

Quality Assurance Requirements for measuring Equipment

##### Part 1: Metrological Confirmation System for Measuring Equipment

##### 1.8 ISO 10013

Guidelines for developing Quality Manuals



Melt flow index testing

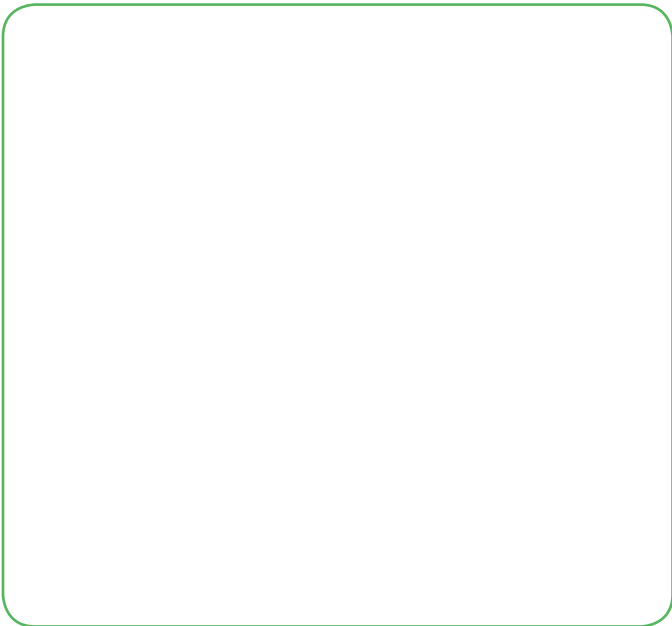


In-Process pressure testing of PP-RCT pipes

## QUALITY ASSURANCE



**Tensile Testing Setup**



**Tensile testing Grips**

The emphasis of this quality system is continuous quality improvement and defect prevention rather than detection after occurrence. The quality system provides operational procedures necessary to maintain control over all activities affecting quality. These procedures provide clear, unambiguous direction as to how corporate quality objectives are to be implemented.

These procedures cover the following:

- 1. Receiving Inspection
- 2. Process control and Analysis
- 3. In-process inspection
- 4. Final inspection and Acceptance

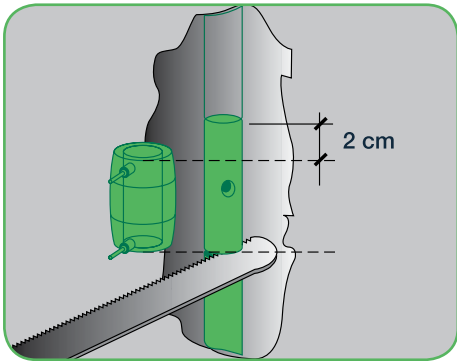
All departments within - **Api** - interact as to their quality related functions to establish and maintain control of production during the manufacturing cycle to ensure compliance with all applicable standards and specifications.

### INSTRUMENTATION

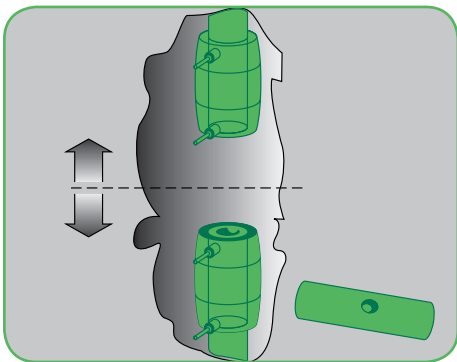
The quality Department provides control and calibration over all measuring and test equipment used in the manufacture of - **Api** -'s products. Control is also exercised over gauges, instruments, sensors and special test equipment used to demonstrate product conformance to specified requirements.

# REPAIRS

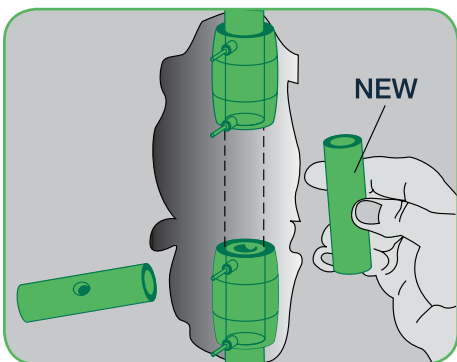
## REPAIR OF DAMAGED PIPE



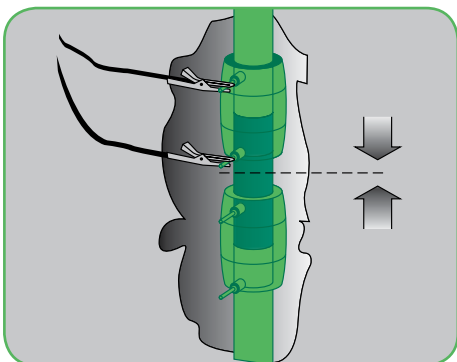
- Cut the damaged pipe perpendicularly, by a length equal to that of the corresponding electric coupling + 2cm



- Remove the section of damaged pipe.
- Carefully clean the surface the two pipe sections to be joined, using sandpaper and solvent liquid and wait till the parts of the pipe are perfectly dry.
- Remove the inner stops from 2 electrical couplings.
- Fully insert the electric couplings into the two pipe sections.



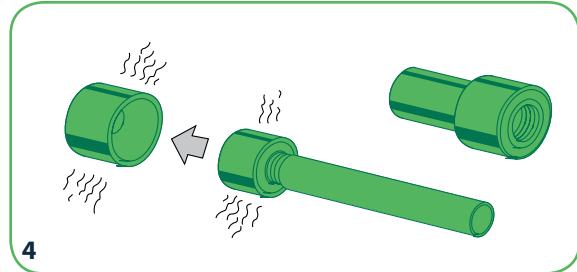
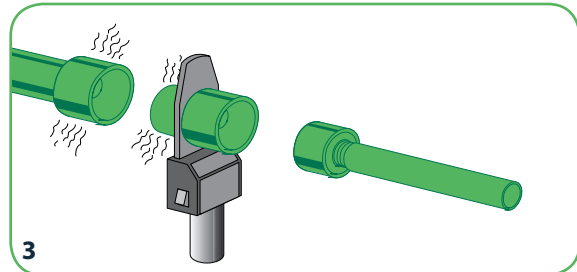
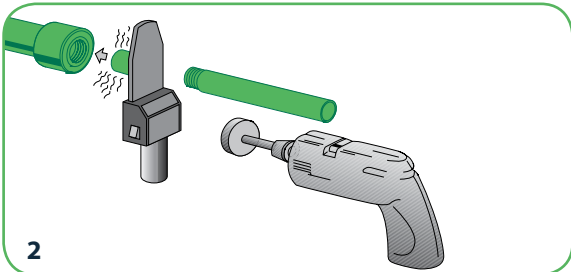
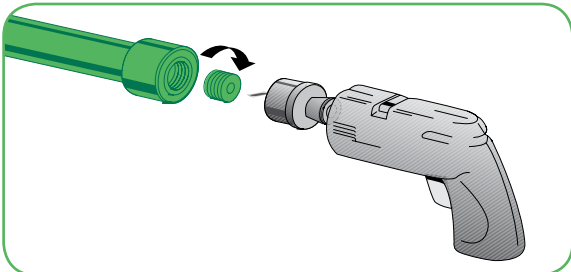
- Cut a pipe section having the same diameter and length as damaged one.
- Fit in the place of the previous.



- Make the 2 electric couplings slide towards the middle of the new pipe piece, by a section equal to half the length of the coupling.
- Weld the couplings (see directions for welding with electric coupling).



## REPAIR OF FEMALE THREADED ADAPTERS



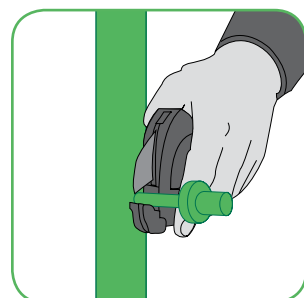
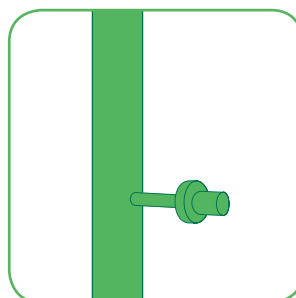
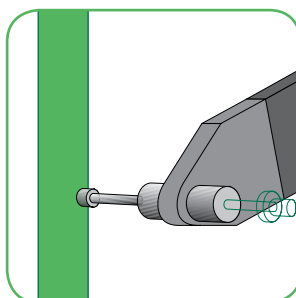
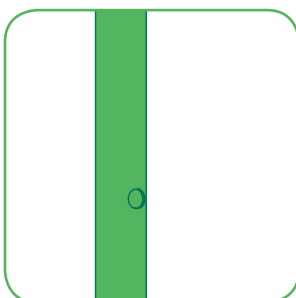
- Install the “drill-centering plug (fig. 1) in the damaged insert.
- Install the “drill-centering plug (fig. 1) in the damaged insert.
- Using a measuring tape, mark a depth of 18 mm on the outside of the saw cup (fig. 1) and start cutting. Use the drill bit and the drill centering plus as guide for the cut. Observe the marked depth.
- Remove the drill-centering plug. Using a standard welding unit, heat the extended die and push into the insert. Heat the extended die and push into the insert. Heat the insert for approximately 1 minute.
- Using a threaded steel pipe, remove the heat insert.

- Using the supplied Rotary cutting bit (fig. 2), smooth the bottom surface of the fitting to remove tear mark developed during the insert removal (do not exceed 0.5 – 1 mm depth).
- Thoroughly clean all surfaces to be weld with alcohol pads.
- Attach the repair insert to the threaded steel pipe. Heat the supplied welding socket using a standard welding unit. Heat the fitting and the repair insert as shown in fig. 3. Use the welding pamaeters for 20mm diameter pipe.
- Join the fitting and the insert as shown in fig. 4.
- Start using the system after 4 minutes of removal of pipe.

### REPAIR OF PUNCTURED PIPE

Should an Apitherm<sup>®</sup> pipe become perforated during the installation process as shown in fig. 1; the perforation can be easily repaired by using a “PP.r Hole Patch”, a “Hole Repair Tool” and a “Standard welding Machine” as shown in fig. 2.

Once the melt of the repair patch and the perforated pipe has solidified, cut the excess section of the patch as shown in fig. 4. The system is realy for use without any drop in pressure rating.



# FLOOR HEATING

## INTRODUCTION TO FLOOR HEATING

### WHAT IS EXACTLY FLOOR HEATING?

For starter, an accurate description would be radiant floor heating. The Greeks and Romans have used the principle of radiant energy to heat their bathhouses. The Koreans have done the same for thousands of years with their homes. Europeans have used hot water piping in the floor for many years. The conduit for the hot water systems was mostly steel or copper piping. The limitations of those materials contributed in the waning interest in these systems in the late fifties early sixties. "Radiant floor Heating" had to wait for chemists to develop polymers that could withstand heat and remove the limitation of steel or copper. PP-RCT is such a polymer.

Still the phenomenon remains misunderstood. The principle is to create a warehouse of heat (a thermal mass), mainly the floor of your dwelling, and to radiate this energy to neighboring objects and people. What this means is that the floor that is few degrees warmer than the ceiling, walls, furniture and people will radiate its heat into the room at a constant rate without the help of unsightly and inefficient heat panels.

The graph below shows two thermal distribution curves in relation to the human body's ideal thermal distribution curves. Curve b depicts the distribution of a "radiant floor heating system", curve c depicts the distribution of a standard "conventional Radiator system".

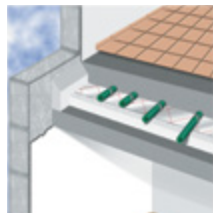
### HOW ARE FLOORS HEATED?

The most prevalent method of heating the floor is the floor is the use of warm water flowing through piping in the floor. Apitherm® piping comes in a standard size of Ø16mm coiled in 150m coils. Figure 2 shows two types of layouts:

- a- Serpentine layout
- b- Counter-flow spiral

### HEAT SOURCE

The benefit of radiant floor heating system is its adaptability and flexibility all that is needed is a source of warm water. The most common way of supply is the use of a standard boiler and the setting for a radiant floor Heating system is the outlet temperature of conventional boiler a radiant floor heating system can be commissioned using solar energy as a heat source to warm water. In some countries this offers an ecological solution and helps in safeguarding the environment.



CROSS-SECTIONAL VIEW OF FLOOR-HEATING SETUP

### DESIGN AND LAYOUT

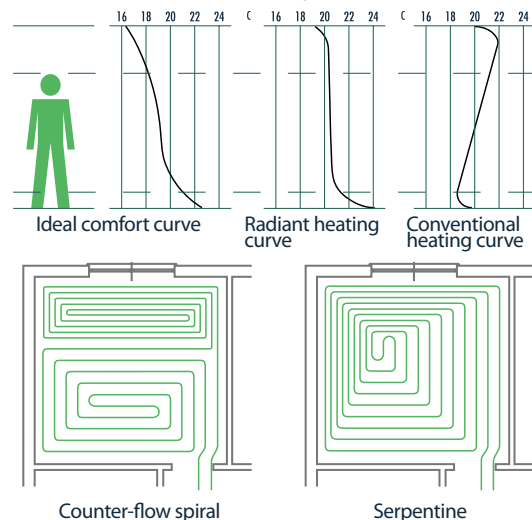
During the design phase, -api- will assist in developing the layout needed for each particular dwelling and the runs of pipe required to achieve an efficient and economical installation. For further detail -api- has developed several technical bulletins related to the subject, which will help the designer in assessing the applicability of the system to the customer's particular design.

### INSTALLATION REQUIREMENTS

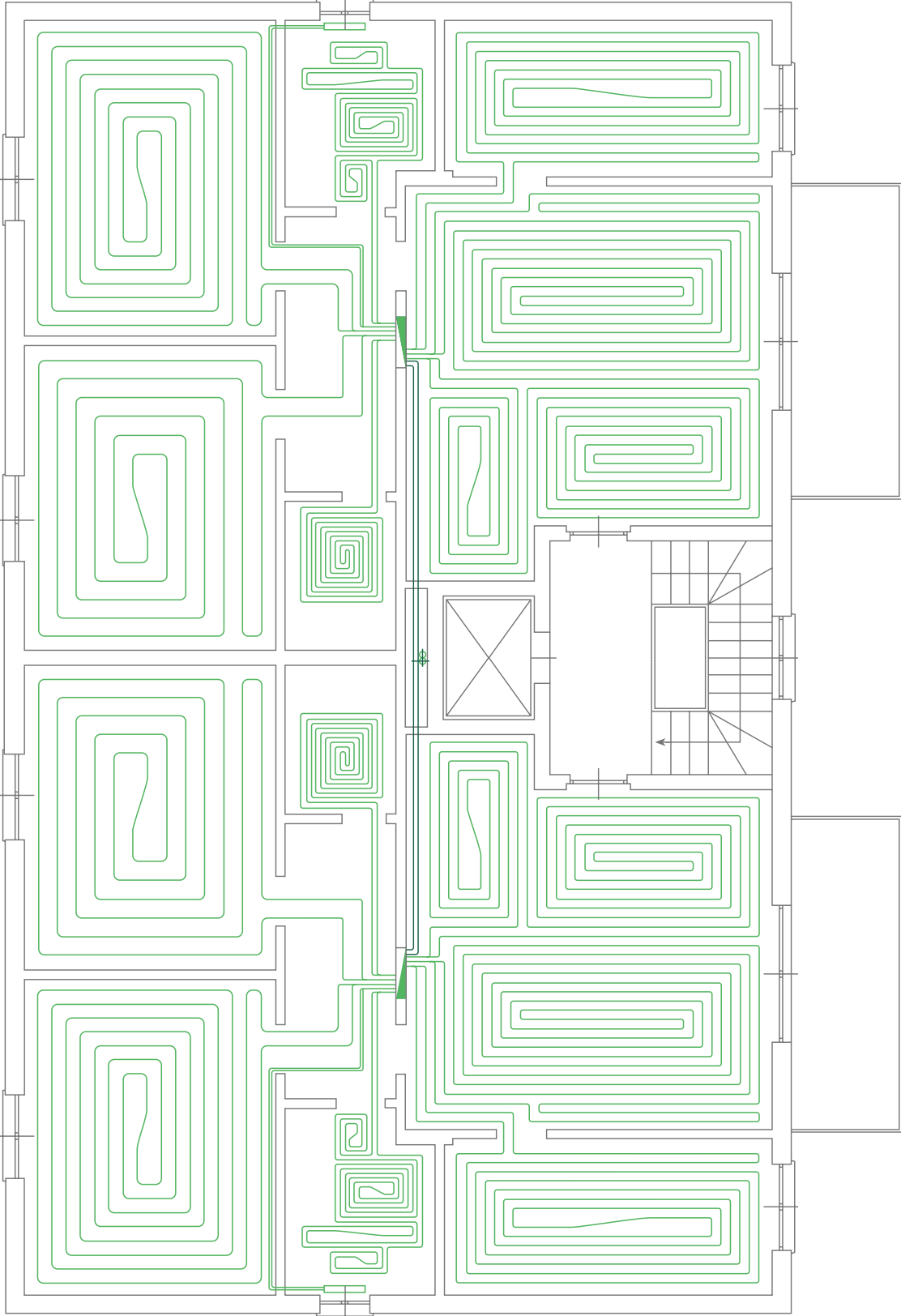
A good "Radiant floor heating system" installation starts with the preparation of a good slab using good construction practices. Once the slab is formed, the insulating material is laid over it, to form a thermal barrier. This will allow the heat energy to radiate in the desirable direction only. After laying the insulating material, a reflective sheet must cover the entire insulated area. Apitherm® piping is laid above the reflective sheet and help in position using special clips developed for this application. Once, all these steps are completed, a steps mix of concrete is poured on top of the piping and allowed to dry. Once the top cover has dried, it can be finished with regular tile. The installation is most beneficial when used on bare tiled floors. If the final cover, is thick carpeting, designers must be notified early in the design phase to include the characteristics of thick carpeting in the calculation procedures.

### OXYGEN PERMEABILITY OF PP-RCT

It is important to consider the oxygen permeability of PP-RCT in "Radiant Floor Heating System". Molecular Oxygen can diffuse through the material and can cause corrosion to metal parts in the circulating system. One principle way to avoid this type of effect is to use corrosion inhibitors. These inhibitors must not have any detrimental effect on PP-r (see Chemical Resistance Section).

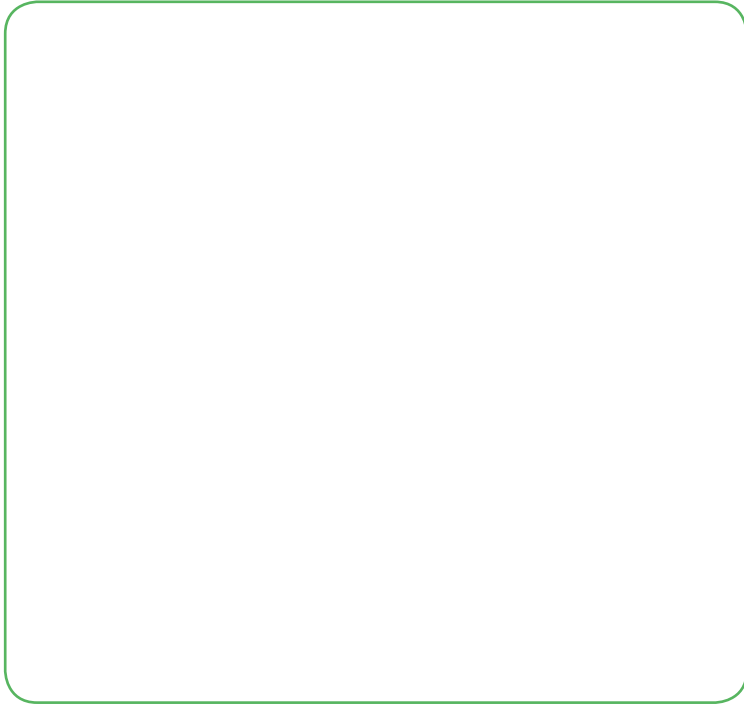


**TYPICAL FLOOR HEATING LAYOUT**

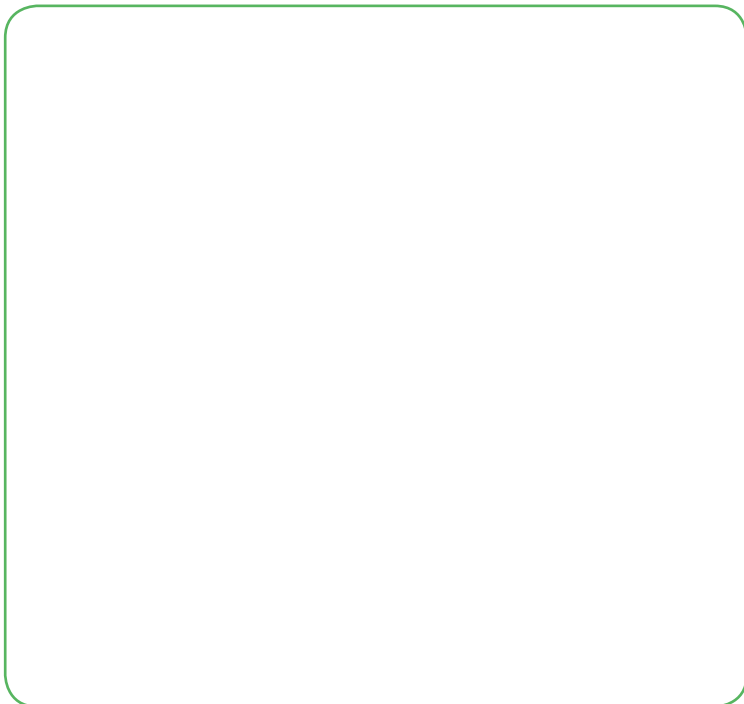


# FLOOR HEATING

## TYPICAL FLOOR HEATING LAYOUT



SERPENTINE FLOOR-HEATING LAYOUT



SPIRAL FLOOR-HEATING LAYOUT

# PRODUCT RANGE

Pipes	78
Pipe class 2	
Pipe class 5	79
Alu-pipe class 2	80
Alu-pipe/uv class 2	81
Couplings class 5	82
Reducer class 5	
90 elbow class 5	83
45 elbow class 5	
Equal tee class 5	
Reducing tee class 5	84
End cap class 5	
Over cross class2	85
90 bend class 5	
Electro-fusion welding socket	
90 Elbow male/female class 5	86
Offset bend class 2	
Offset bend class 5	
Welding saddle class 2	
Flange adaptor class2	87
Backing flange	88
Flange seal	
Fixed mixed support	
Cross bend class 5	
Extension kit	
Female threaded adaptor class 5	89
Male threaded adaptor class 5	
Female threaded 90 elbow class 5	
Female threaded 90 elbow class 5 (slim design)	
Male threaded 90 elbow class 5	
Male threaded 90 elbow class	90
Female threaded 90 tee class 5	
Male threaded 90 tee class 5	
Male threaded pluge for body valves	
Union(male threaded) class 2	91
Copper union	
Female threaded elbow class 5 (fixing brackets)	
Body valve	
Female collector	92
Stop valve (encastree)	
Shut off valve(handle wheel exposed)	
Shut off valve (chromed handle)	
Ball valve encastree complete	93
Ball valve exposed	
Male thread for exposed ball valve	
Protection cap	
Welding sockets (male/female)	94
Clips for pipes	
Fittings butt-fusion welding	95
Reducer class 2	
Equal tee class2	
End cap class 2	
90 elbow class 2	96
45 elbow class 2	
Welding machine	97
Pipe cutters	
Saddle(female/male) socket	
Alu-pipe peeler	98
Calibration tools for peeler	
Leveler	99
Repair sockets	

# PRODUCT RANGE

## PIPE CLASS 2 – SERIES 3.2



**MATERIAL:** PP – RCT (BETA PP-R)

**STANDARDS:** EN ISO 15874 /DIN 8807/ DIN 8078.

**ACCORDING TO:** SKZ.

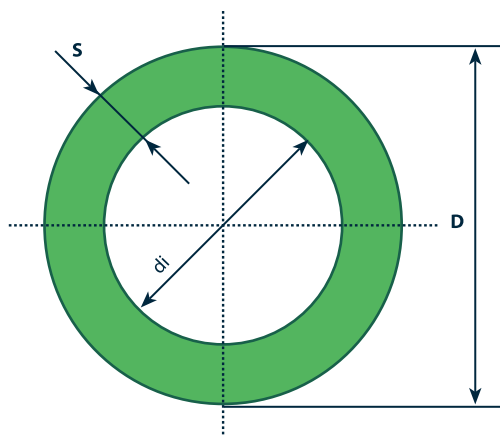
**SKZ NO:** A 523.

**PACKING:** 4M STRAIGHT LENGTH.

**PACKING UNIT:** BUNDLES.

**COLOR:** GREEN

**FIELDS OF APPLICATION:** FOR ANY FURTHER DETAIL RELATED TO WORKING TEMPERATURE, PRESSURE, LOAD AND SERVICE YEARS, REFER TO CHAPTER 1 "DESIGN FACTS" PAGE 6 / FIELDS OF APPLICATION (PP-RCT)



API Code	D (mm)	Dn (inches)	d i	s	Kg/m
1202050100	20	1/2"	14.4	2.8	0.148
1202050200	25	3/4"	18	3.5	0.230
1202050300	32	1"	23.2	4.4	0.370
1202050400	40	1 1/4"	29	5.5	0.575
1202050500	50	1 1/2"	33.2	6.9	0.896
1202050600	63	2"	45.8	8.6	1.41
1202050700	75	2 1/2"	54.4	10.3	2.01
1202050800	90	3"	65.4	12.3	2.87
1202050900	110	4"	79.8	15.1	4.3
1202051000	125	5"	90.8	17.1	5.53
1202051200	160	6"	116.2	21.9	9.04



Upon request

## PIPE CLASS 5 – SERIES 2.5



**MATERIAL :** PP-RCT (BETA PP-R)

**STANDARDS:** EN ISO 15874 / DIN 8077 / DIN 8078.

**ACCORDING TO:** SKZ .

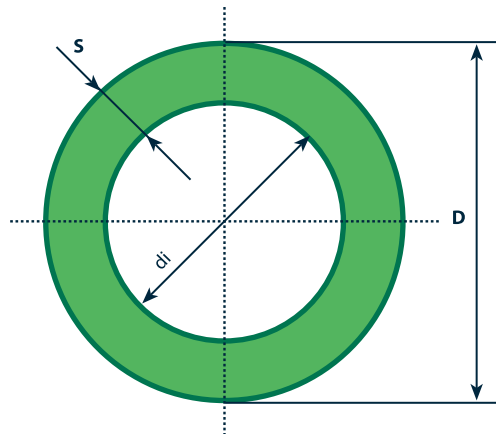
**SKZ NO:** A 523.

**PACKING:** 4M STRAIGHT LENGTH

**PACKING UNIT:** BUNDLES.

**COLOR:** GEERN WITH RED STRIPES

**FIELDS OF APPLICATION:** FOR ANY FURTHER DETAIL RELATED TO WORKING TEMPERATURE, PRESSURE, LOAD AND SERVICE YEARS,REFER TO CHATER 1 “DESIGN FACTS” PAGE 6 OF APPLICATION (PP-RCT)



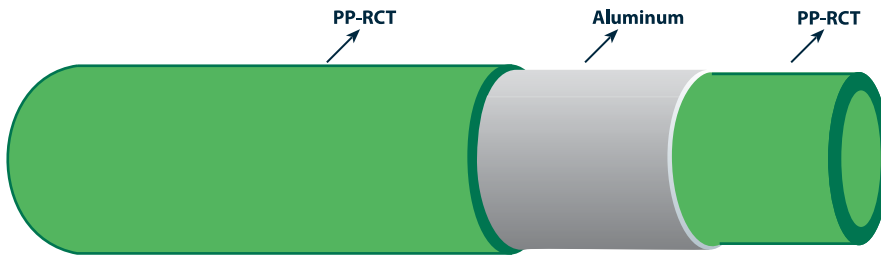
API Code	D	D (inches)	d i	s	Kg/m
1205050100	20	1/2"	13.2	3.4	0.172
1205050200	25	3/4"	16.6	4.2	0.266
1205050300	32	1"	21.2	5.4	0.434
1205050400	40	1¼"	26.6	6.7	0.671
1205050500	50	1½"	33.4	8.3	1.04
1205050600	63	2"	42	10.5	1.65
1205050700	75	2½"	50	12.5	2.34
1205050800	90	3"	60	15	3.36
1205050900	110	4"	73.4	18.3	5.01



Upon request

# PRODUCT RANGE

## ALU-PIPE CLASS 2 – SERIES 3.2 (AVAILABLE UPON REQUEST)



**MATERIAL :** PP-RCT JOINT WITH ALUMINUM

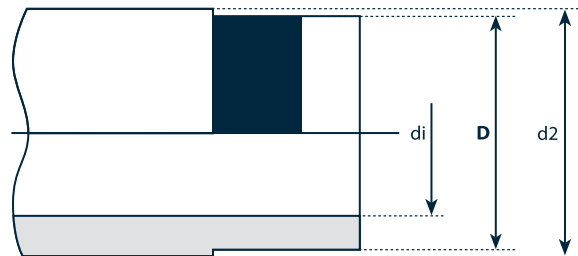
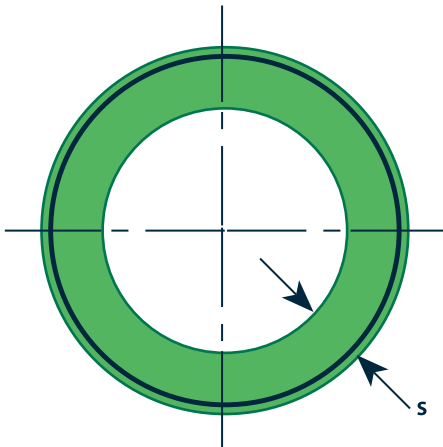
**STANDARDS:** EN ISO 15874 / DIN 8077 / DIN 8078.

**PACKING:** 4M STRAIGHT LENGTH.

**PACKING UNIT:** BUNDLES.

**COLOR:** GREEN

**FIELDS OF APPLICATION:** APITHERM® ALU-PIPE CLASS 2 TESTED CLASS 5 IS BEST USED IN TRANSPORTING HOT AND COLD WATER IN RISERS AND EXPOSED INSTALLATIONS.

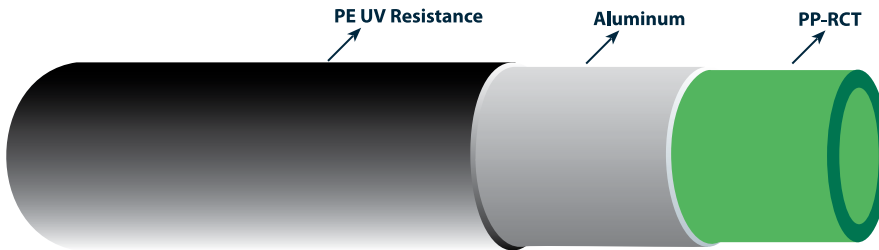


API Code	D (mm)	Dn (inches)	d i	d2	s	Kg/m
1202060100	20	1/2"	14.4	21.9	2.8	0.210
1202060200	25	3/4"	18	27.1	3.5	0.290
1202060300	32	1"	23.2	34.1	4.4	0.466
1202060400	40	1 1/4"	29	42.3	5.5	0.701
1202060500	50	1 1/2"	36.2	52.3	6.9	1.054
1202060600	63	2"	45.8	65.3	8.6	1.573
1202060700	75	2 1/2"	54.4	77.3	10.3	2.190

Upon request



## ALU-PIPE / UV CLASS 2 SERIES 3.2



**MATERIAL :** PP-RCT / ALUMINUM LAYER / PE COATING

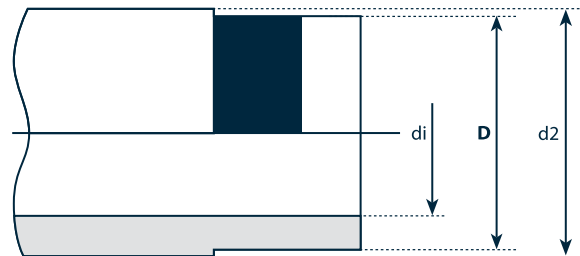
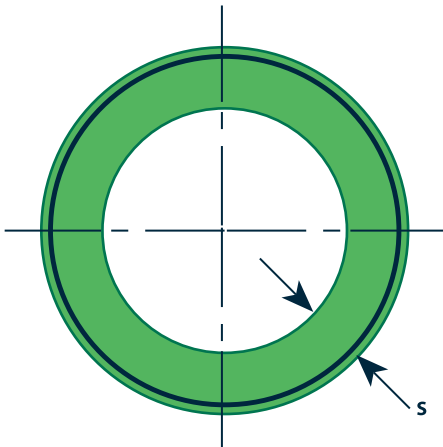
**STANDARDS:** EN ISO 15874 / DIN 8077 / DIN 8078.

**PACKING:** 4M STRAIGHT LENGTH.

**PACKING UNIT:** BUNDLES.

**COLOR:** BLACK.

**FIELDS OF APPLICATION:** APITHERM® ALU-PIPE UV RESISTANT CLASS 2 TESTED CLASS 5 IS BEST USED IN TRANSPORTING HOT AND COLD WATER IN RISERS, EXPOSED AND OUTDOOR INSTALLATIONS WHERE UV RESISTANCE IS REQUIRED.



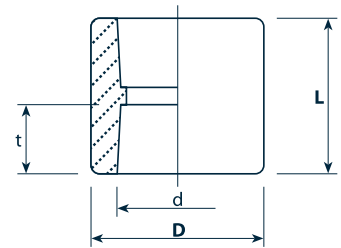
API Code	D (mm)	Dn (inches)	d i	d2	s	Kg/m
1202070100	20	1/2"	14.4	21.9	2.8	0.210
1202070200	25	3/4"	18	27.1	3.5	0.290
1202070300	32	1"	23.2	34.1	4.4	0.466
1202070400	40	1 1/4"	29	42.3	5.5	0.701
1202070500	50	1 1/2"	36.2	52.3	6.9	1.054
1202070600	63	2"	45.8	65.3	8.6	1.573
1202070700	75	2 1/2"	54.4	77.3	10.3	2.190

# PRODUCT RANGE

## FITTINGS SOCKET – FUSION WELDING

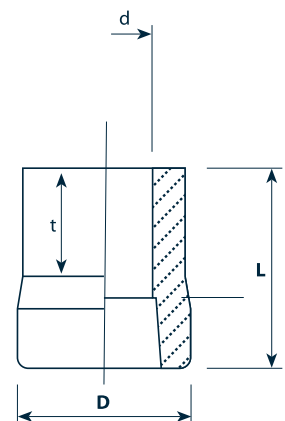
### COUPLING CLASS 5

API Code	d	D	t	L
1215110100	20	30	16	35
1215110200	25	36	18	40
1215110300	32	43	20	43
1215110400	40	57	22	48
1215110500	50	70	25	53
1215110600	63	88	29	64
1215110700	75	104.5	35	83
1215110800	90	127	36	79
1215110900	110	152	39	93
1215111000	125	160	42	93



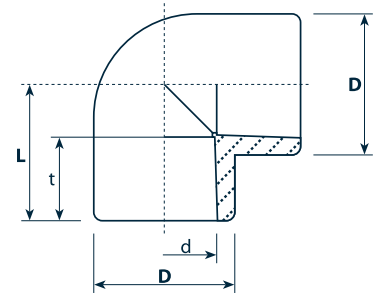
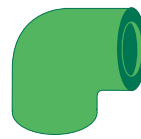
### REDUCER CLASS 5

API Code	d	D	t	L
1215120201	25	20	16	40
1215120301	32	20	16	40
1215120302	32	25	18	44
1215120401	40	20	16	41
1215120402	40	25	18	48
1215120403	40	32	20	48
1215120502	50	25	22	50.5
1215120503	50	32	22	56
1215120504	50	40	25	56
1215120604	63	40	22	64
1215120605	63	50	23.5	64
1215120704	75	40	30	77
1215120705	75	50	27.4	67.5
1215120706	75	63	30	72
1215120806	90	63	27.4	78
1215120807	90	75	30	88
1215120906	110	63	27.4	86.9
1215120907	110	75	30	89.5
1215121007	125	75	30	92
1215120908	110	90	33	92
1215121008	125	90	42	103
1215121009	125	110	42	103



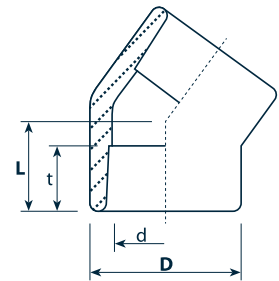
## 90° ELBOW CLASS 5

API Code	d	D	t	L
1215130100	20	30	16	27
1215130200	25	36	18	31
1215130300	32	44	20	36
1215130400	40	51	22	42
1215130500	50	64	25	50
1215130600	63	83	29	61
1215130700	75	104.5	34	75
1215130800	90	127	35	86
1215130900	110	152	40	98
1215131000	125	166	42	135



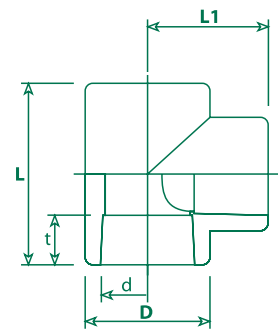
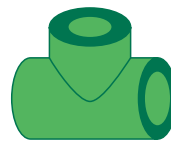
## 45° ELBOW CLASS 5

API Code	d	D	t	L
1215140100	20	30	16	202
1215140200	25	36	18	5
1215140300	32	44	20	28
1215140400	40	54	22	31
1215140500	50	66	25	36
1215140600	63	84	29	44
1215140700	75	103.5	34	57
1215140800	90	127	35	62
1215140900	110	153	40	75
1215141000	125	166	42	117



## EQUAL TEE CLASS 5

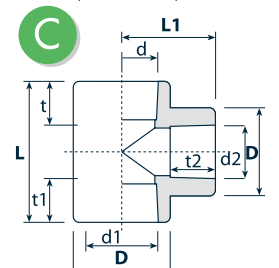
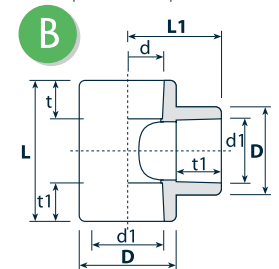
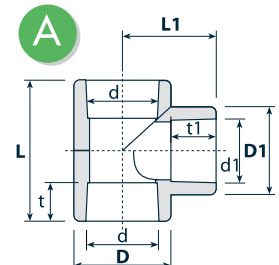
API Code	d	D	t	L	L1
1215140100	20	30	16	54	27
1215140200	25	36	18	63	32
1215140300	32	44	20	75	37
1215140400	40	53	22	85	43
1215140500	50	67	25	102	51
1215140600	63	84	29	122	60
1215140700	75	104	34	150.5	76
1215140800	90	127	35	161.5	80
1215140900	110	153	40	194	97
1215141000	125	166	42	273	142



# PRODUCT RANGE

## REDUCING TEE CLASS 5

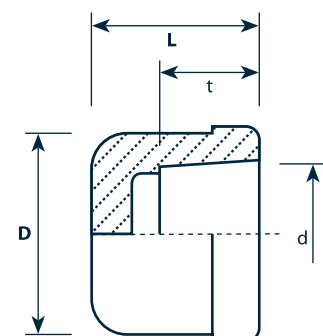
API Code	Type	d	D	d1	d2	t	t1	L	L1	D1
1215160211	B	25	34	20		18	16	63	32	
1215160212	A	25	34	20		18	16	63	32	
1215160221	B	20	34	25		16	18	63	32	
1215160311	B	32	42	20		20	16	75	39	
1215160312	C	32	42	25	20	20	16	75	39	
1215160313	A	32	42	20		20	16	75	39	
1215160321	C	32	42	20	25	20	18	75	39	
1215160322	B	32	42	25		20	18	75	39	
1215160323	A	32	42	25		20	18	75	39	
1215160331	B	20	42	32		16	20	75	39	
1215160332	B	25	42	32		18	20	75	39	
1215160414	A	40	56	20		22	16	85	39	30
1215160424	A	40	53	25		22	18	85	43	
1215160433	B	40	56	32		22	20	86	41	
1215160434	A	40	53	32		22	20	85	43	
1215160502	A	50	69	25		25	18	106	54	50
1215160503	A	50	67	32		25	20	102	51	
1215160504	A	50	67	40		25	22	102	51	
1215160602	A	63	87	25		30			58	53.5
1215160603	A	63	87	32		30	20		58	53.5
1215160604	A	63	84	40		29	22	122	60	
1215160605	A	63	84	50		29	25	122	60	
1215160705	A	75	104	50		33	24.7	128	64	70
1215160706	A	75	105	63		33	30	142	72	88
1215160805	A	90	127	50		34	25	143	71	70
1215160806	A	90	127	63		33	30	152	75	88
1215160807	A	90	127	75		33	33	162	90	105
1215160906	A	110	185	63		40	30	173	89	88
1215160907	A	110	154	75		40	33		100	105
1215161908	A	110	154	90		40	36	184	100	127
1215161008	20	125		90						
1215161009	20	125		110						



Upon request

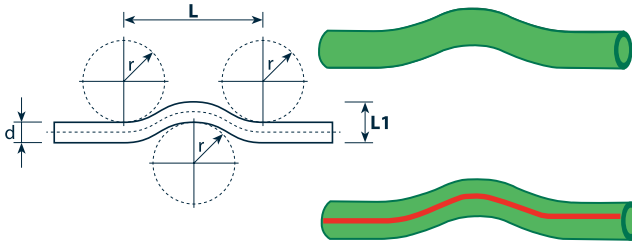
## END CAP CLASS 5

API Code	d	D	t	L
1215170100	20	30	16	29
1215170200	25	36	18	35
1215170300	32	44	20	41
1215170400	40	54	22	38
1215170500	50	66	25	44
1215170600	63	83	29	52
1215170700	75	104	35	51
1215170800	90	126	35	76
1215170900	110	152.5	40	64
1215171000	125	166	42	73



# PRODUCT RANGE

## OVER CROSS CLASS 2



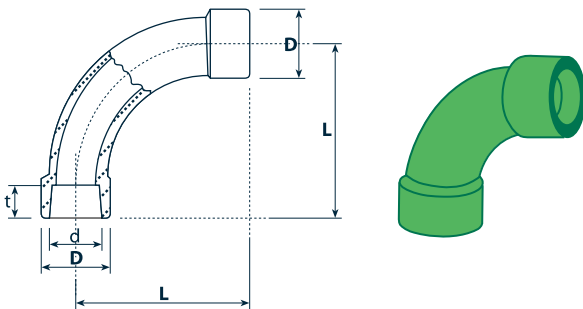
API Code	d	r	L	L1
1212180100	20	20	130	43
1212180200	25	62	162	53
1212180300	32	80	206	70

## OVER CROSS CLASS 5



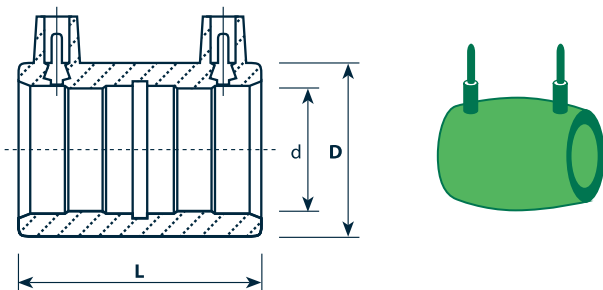
API Code	d	r	L	L1
1215180100	20	20	130	43
1215180200	25	62	162	53
1215180300	32	80	206	70

## 90° BEND CLASS 5



API Code	d	D	t	L
1215190100	20	29	16	62
1215190200	25	34	16	70.5
1215190300	32	42	18	88

## ELECTRO - FUSION WELDING SOCKET

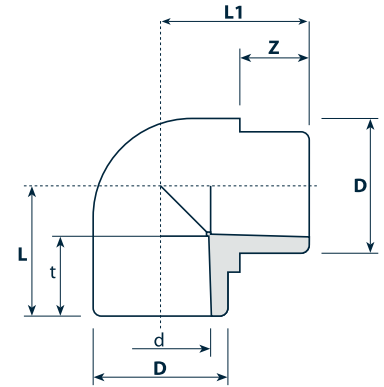
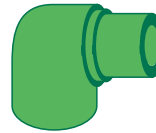


API Code	d	D	L
2110100	20	30	55
2110200	25	36	60
2110300	32	44	70
2110400	40	52	80
2110500	50	66	90
2110600	63	80	105

# PRODUCT RANGE

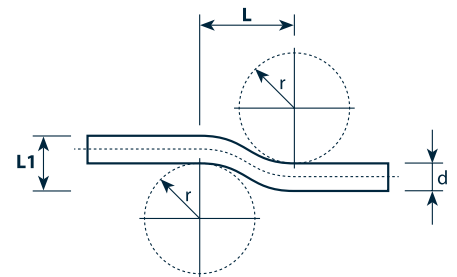
## 90° ELBOW MALE / FEMALE CLASS 5

API Code	d	D	Z	L	t	L1
1215200100	20	29	12.5	27	16	33.5
1215200200	25	35	18	31	18	38.5



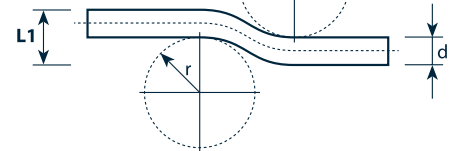
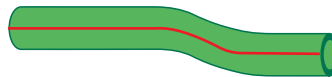
## OFFSET BEND CLASS 2

API Code	d	L	L1
1212210100	20	80	21.5
1212210200	25	88	25



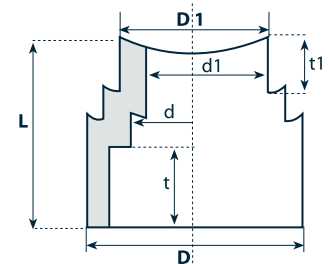
## OFFSET BEND CLASS 5

API Code	d	L	L1
1215210100	20	80	21.5
1215210200	25	88	25



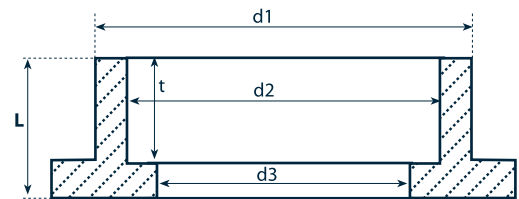
## WELDING SADDLE CLASS 2

API Code	Size	d	D	d1	D1	t	t1	L
1212220603	63x32	32	42	21	32.5	19	10	49
1212220703	75x32	32	42.5	21	32.5	19	12.7	50
1212220704	75x40	40	55	26.5	40.5	23	12.7	58
1212220803	90x32	32	42.5	21	32.5	19	15	53
1212220804	90x40	40	55	26.5	40.5	23	15	58
1212220906	110x63	63	84	42	63.6	27.5	17.9	78



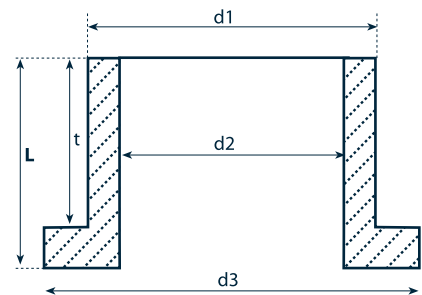
## FLANGE ADAPTOR CLASS 2 (SHORT DESIGN)

API Code	Size	d1	d2	d3	t	L
1212230800	90	107	90	78.3	33	42
1212230900	110	135	110	96.1	40	52



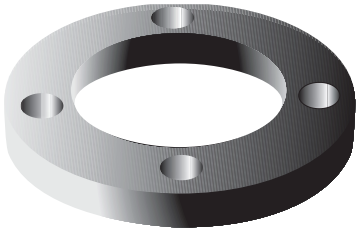
## FLANGE ADAPTOR CLASS 2 (LONG DESIGN)

API Code	Size	d1	d2	d3	t	L
1212250600	63	63	75	104	54	89
1212250700	75	54	54	122	78	111
1212251000	125	125	90.8	155	107	150
1212251200	160	160	116	212	122	146



# PRODUCT RANGE

## BACKING FLANGE

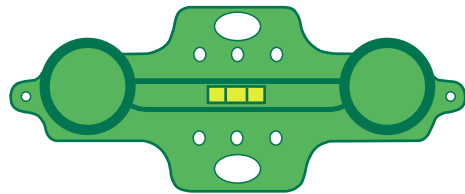


## FLANGE SEAL



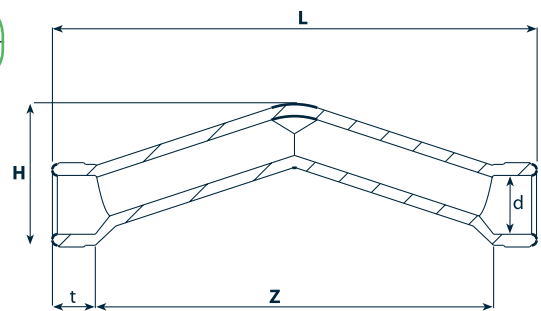
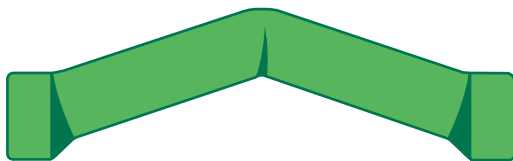
## FIXED MIXER SUPPORT

API Code	Dimension
1215240101	20 x 1/2" - 16 cm
1215240201	25 x 1/2" - 16 cm



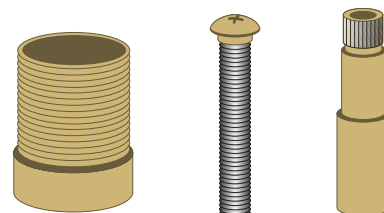
## CROSS BEND CLASS 5

API Code	d	t	H	Z	L
121526200	25	17	57	163	197



## EXTENSION KIT

API Code	Dimension
2309000	3/4" & 1"
2309050	All Dimensions

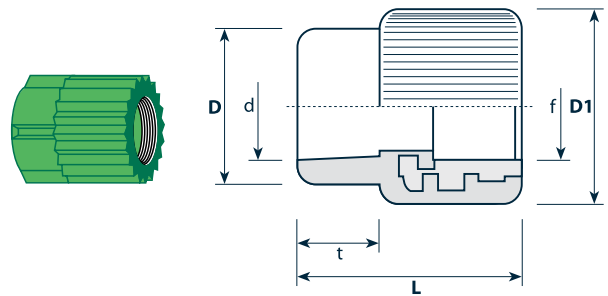


\* ITEM 2309050 IS USED FOR "BALL VALVES" ONLY.



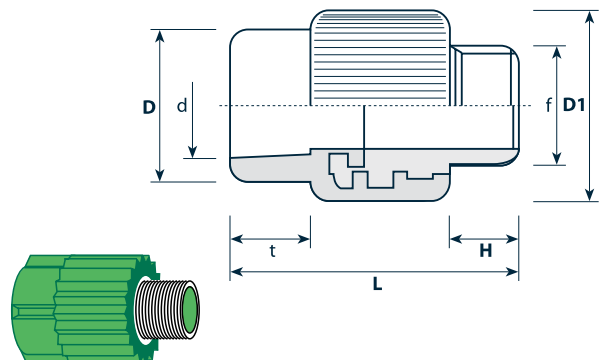
## FEMALE THREADED ADAPTOR CLASS 5

API Code	d	f	D	D1	t	L
1225410101	20	1/2"	27	37	16	41
1225410201	25	1/2"	34	47	18	46
1225410202	25	3/4"	34	47	18	46
1225410303	32	1"	42	62	20	63
1225410404	40	1 1/4"	54	73	22	75
1225410505	50	1 1/2"	66	80	25	80
1225410606	63	2"	84	90	29	80
1225410707	75	2 1/2"	104	119	35	88.6
1225410808	90	3"	130	138	35	111
1225410909	110	4"	154	164	40	125



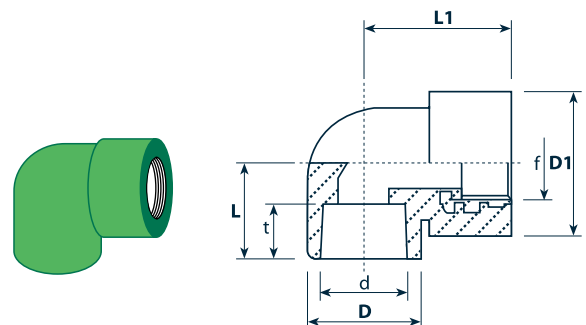
## MALE THREADED ADAPTOR CLASS 5

API Code	d	f	D	D1	t	L	H
1225420101	20	1/2"	28	38	16	55	14
1225410201	25	1/2"	35	46	18	60	14
1225410202	25	3/4"	34	46	18	60	14
1225410303	32	1"	42	61	20	83	32
1225410404	40	1 1/4"	54	74	22	94	40
1225410505	50	1 1/2"	70	80	25	99	40
1225410606	63	2"	84	90	29	100	20
1225410707	75	2 1/2"	104	119	35	117	49.5
1225410808	90	3"	130	138	35	132	31
1225410909	110	4"	154	164	40	163	37



## FEMALE THREADED 90° ELBOW CLASS 5

API Code	d	f	D	D1	t	L	L1
1225430101	20	1/2"	30	37	16	27	33
1225430201	25	1/2"	36	44	18	30	38
1225430202	25	3/4"	36	44	18	30	38
1225430303	32	1"	42	54	20	35	58



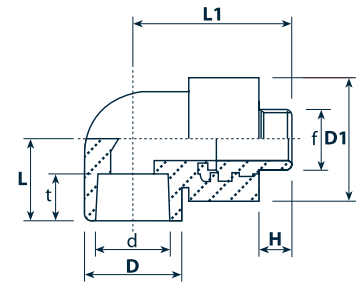
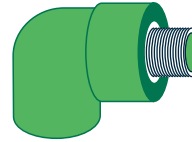
## FEMALE THREADED 90° ELBOW CLASS 5 (SLIM DESIGN)

API Code	d	f	D	D1	t	L	L1
1225580201	25	1/2"	36.5	39.5	16.5	28	35

# PRODUCT RANGE

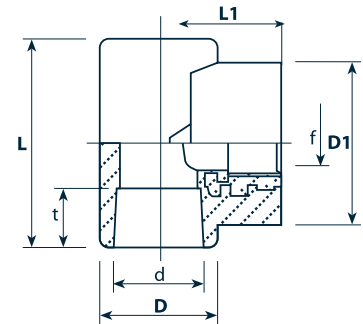
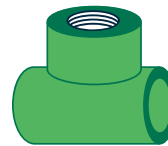
## MALE THREADED 90° ELBOW CLASS 5

API Code	d	f	D	D1	t	L	L1	H
1225440101	20	1/2"	30	37	16	27	37	14
1225440202	25	3/4"	36	44	18	30	52	14
1225440201	25	1/2"	36	44	18	30	52	14
1225440303	32	1"	42	54	20	35	73	20



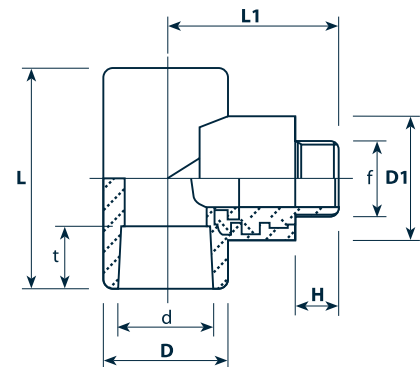
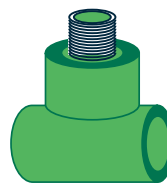
## FEMALE THREADED 90° TEE CLASS 5

API Code	d	f	D	D1	t	L	L1
1225450101	20	1/2"	30	37	16	54	33
1225450202	25	3/4"	36	44	18	61	38
1225450201	25	1/2"	36	44	18	61	38
1225450303	32	1/2"	42	54	20	74	44



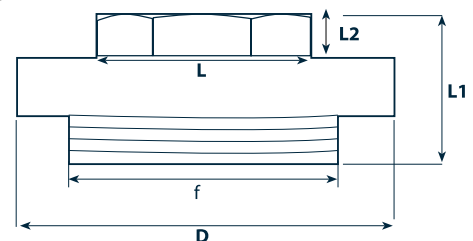
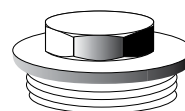
## MALE THREADED 90° TEE CLASS 5

API Code	d	f	D	D1	t	L	L1	H
1225460101	20	1/2"	30	37	16	54	47	14
1225460202	25	3/4"	36	45	18	61	52	14
1225460201	25	1/2"	36	45	18	61	52	14



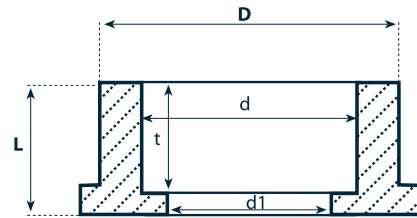
## MALE THREADED PLUG BODY VALVES

API Code	f	D	L	L1	L2
2207200	3/4"	32.5	26	19	7
2207300	1"	41	26	22	8
2207400	1 1/4"	47.5	26	23	8.5
2207500	1 1/2"	56	32	25	10



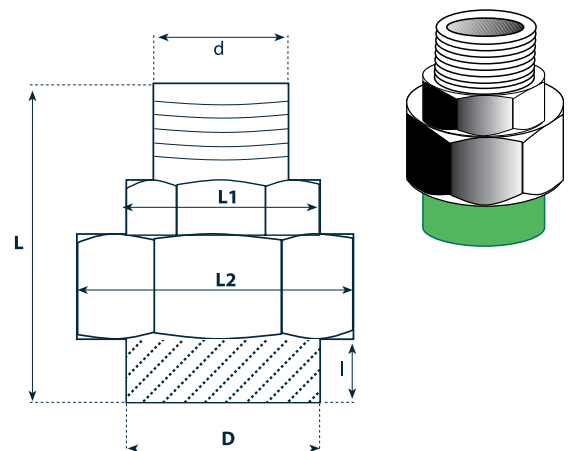
## UNION (MALE THREADED) CLASS 2

API Code	Size	d	D	d1	t	L
1225480101	20	20	27	14.5	15.5	19
1225480202	25	25	36	19	16	22
1225480303	32	32	41	25	17	23
1225480404	40	40	51	34	22	27
1225480505	50	50	66.5	42	22.5	27
1225480606	63	63	84	54.5	27	30



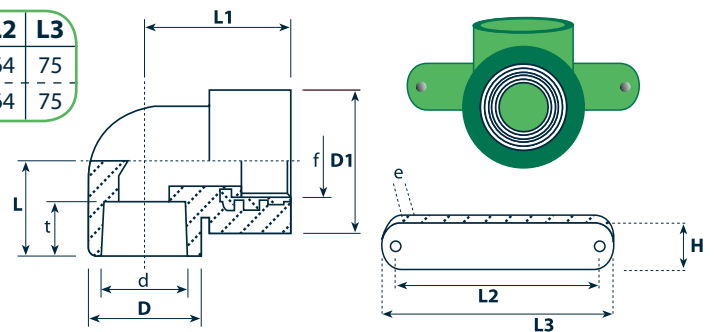
## COPPER UNION

Size	D	d	L	L1	L2	I
20	27	21	45	27	41	7
25	36	26	56	32.5	47	13
32	41	32.5	65	37.5	52	11
40	51	41	75	47	68	15
50	66.5	48	55	58	88	15
63	84	59	62	68	107	18



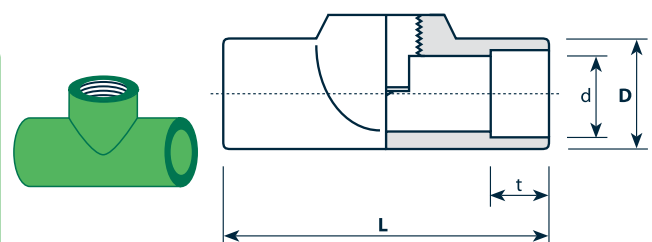
## FEMALE THREADED ELBOW CLASS 5 (WITH FIXING BRACKETS)

API Code	d	f	D	D1	t	L	L1	H	e	L2	L3
1225570101	20	1/2"	27	37	16	27	33	19	6	64	75
1225570201	25	1/2"	36.5	39.5	16.5	28	35	19	6	64	75



## BODY VALVE

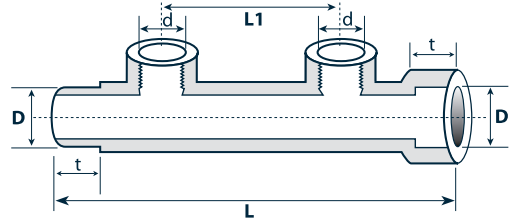
API Code	Size	d	D	t	L
1225480101	20 x 3/4"	20	36	16	96
1225480202	25 x 4/3"	25	36	18	96
1225480303	32 x 1"	32	47	20	93
1225480404	40 x 1 1/4"	40	56	22	123
1225480505	50 x 1 1/2"	50	70	27	141
1225480606	63 x 2"	63	88.5	28	180



# PRODUCT RANGE

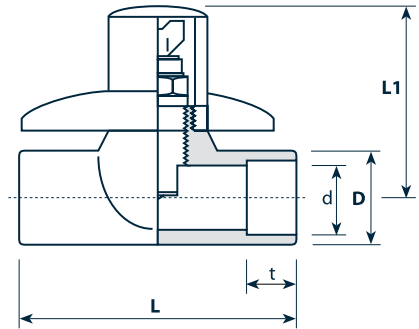
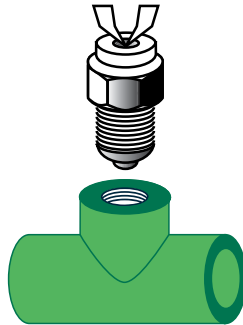
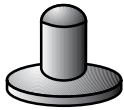
## FEMALE COLLECTOR

API Code	D	d	t	L	L1
1225600503	50	1"	25	320	150



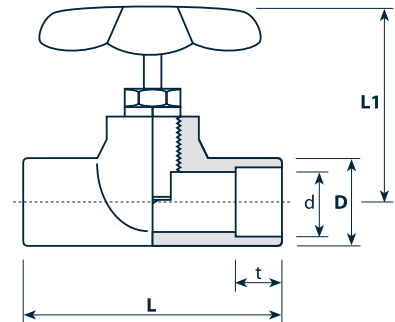
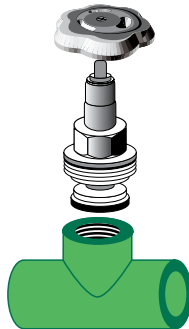
## STOP VALVE (ENCASTRÉE)

API Code	Size	L1
2408220	3/4"	75



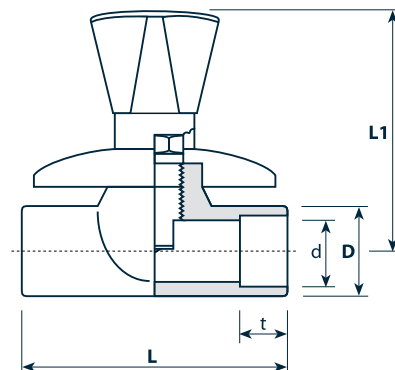
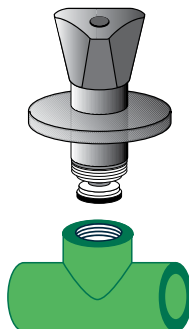
## SHUT OFF VALVE (HANDLEWHEEL EXPOSED)

API Code	Size	L1
2410220	3/4"	75
2420220	1"	125
2430220	1 1/4"	117
2440220	1 1/2"	135
2450220	2"	157



## SHUT OFF VALVE (CHROMED HANDLE)

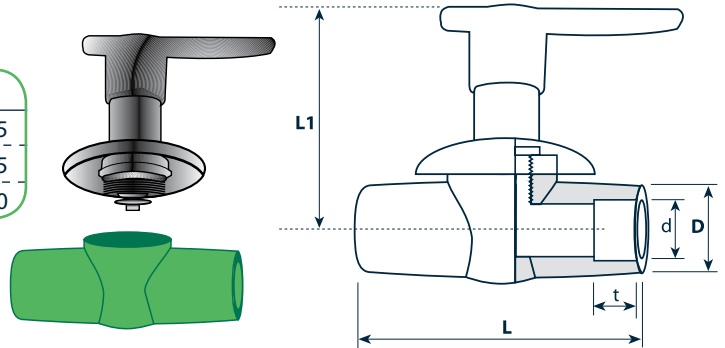
API Code	Size	L1
2412220	3/4"	100
2422220	1"	100



# PRODUCT RANGE

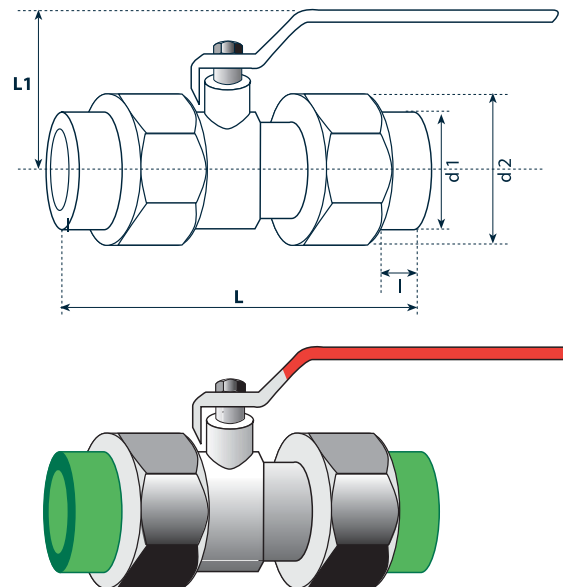
## BALL VALVE ENCASTREE COMPLETE

API Code	Size	d	D	t	L1	L
1225510102	20	20	32.5	16	90	105
1225510202	25	25	32.5	18	90	105
1225510303	32	32	42	20	93	120



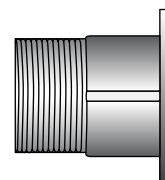
## BALL VALVE EXPOSED

API Code	Size	d1	d2	l	L1	L2
1225520101	20	27	42	11.5	48	86
1225520202	25	33	50	13	53	94
1225520303	32	42.5	56	14	66	108
1225520404	40	53	73	18	70	126
1225520505	50	66.5	91	23	75	150
1225520606	63	84.5	113	26	79	176



## MALE THREAD FOR EXPOSED BALL VALVE\*

API Code	Dimension (mm)
1225530303	1"
1225530404	1 1/4"
1225530505	1 1/2"



\* Above item could be connected to the exposed Ball Valve (Item#122552)

## PROTECTION CAP

API Code
OVD 3180



# PRODUCT RANGE

## WELDING SOCKETS (MALE)

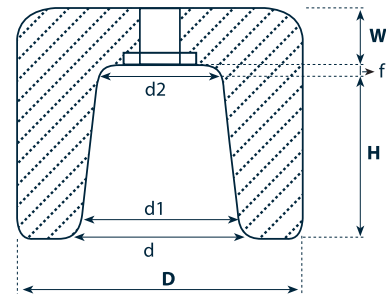
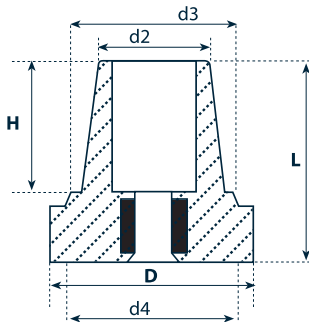


## WELDING SOCKETS (FEMALE)



API Code	d	d1	d2	d3	d4	D	H	L
2304100	20	11	19.25	19.50	22	34	14	26
2304200	25	11	24.20	24.48	26	34	15	27.5
2304300	32	11	31.15	31.46	34	35	16.5	29.5
2304400	40	20	39.05	39.40	42	44	18	32
2304500	50	25	49	49.48	52	54	20	35
2304600	63	39	61.90	62.33	66	69	24	39
2304700	75	52	73	73.8	80	84	31	46
2304800	90	60	88	89.4	93	100	29	45
2304900	110	78	108	109.5	114.5	118	33	49
2305000	125	90	123	124.5	128.5	140	42	54

d	d1	d2	D	H	f	W
20	20	19.8	34	12	4	10.5
25	24.98	24.75	39	13	4	10.5
32	31.95	31.70	49	14.5	5	10.5
40	39.9	39.65	58	16	5	11
50	49.85	49.5	69	18	5	12.5
63	62.8	62.4	79	24	6	12.5
75	74.6	74.15	92	35	4	9
90	89.8	89.2	109	31	4	10
110	109.6	109	129	35	4	10
125	124.5	123	146	39	4	9



## CLIPS FOR PIPES

### GREEN COLOR

API Code	Dimension (mm)
1531200100	20
1531200200	25
1531200300	32
1531200400	40

### BLACK COLOR

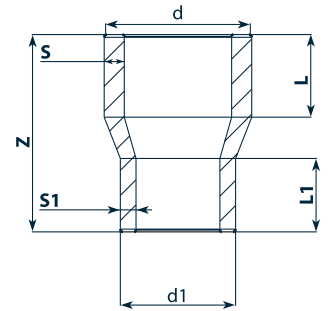
API Code	Dimension (mm)
1532200100	20
1532200200	25
1532200300	32
1532200400	40

## FITTINGS BUTT-FUSION WELDING

### REDUCER CLASS 2\*

API Code	d - d1	S	S1	L	L1	Z
T.B.A	160 - 110	21.9	15.1	90	80	215
T.B.A	160 - 125	21.9	17.1	90	80	215

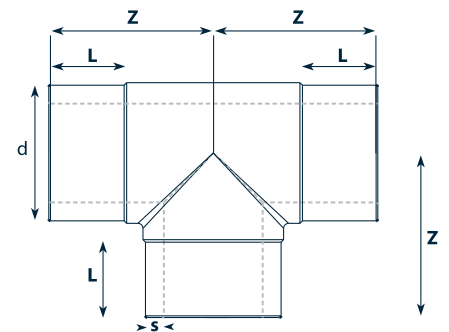
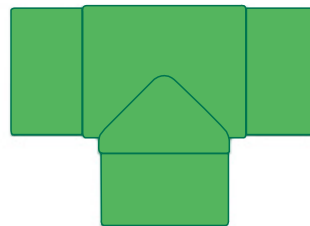
"T.B.A": To be Announced.



### EQUAL TEE CLASS 2\*

API Code	D	S	L	Z
T.B.A	160	21.9	90	196

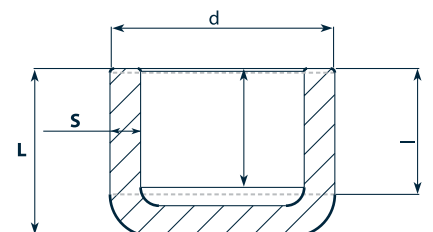
"T.B.A": To be Announced.



### END CAP CLASS 2\*

API Code	d	S	L	I
T.B.A	160	21.9	115	90

"T.B.A": To be Announced.



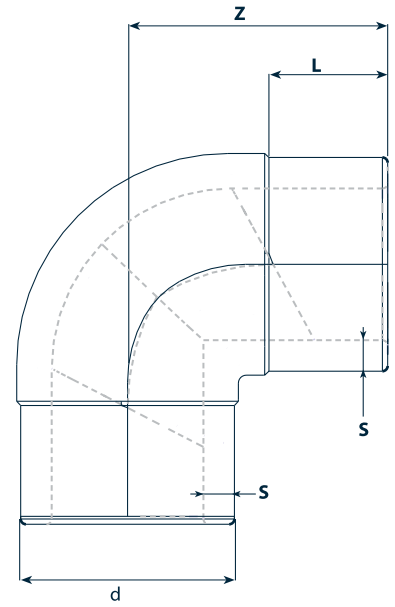
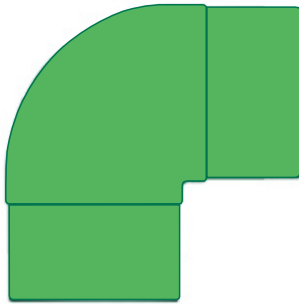
\*Above mentioned fittings use both Butt - Fusion welding and Electro - fusion welding techniques  
\* Available upon request

# PRODUCT RANGE

## 90° ELBOW CLASS 2\*

API Code	D	S	L	Z
T.B.A	160	21.9	90	196

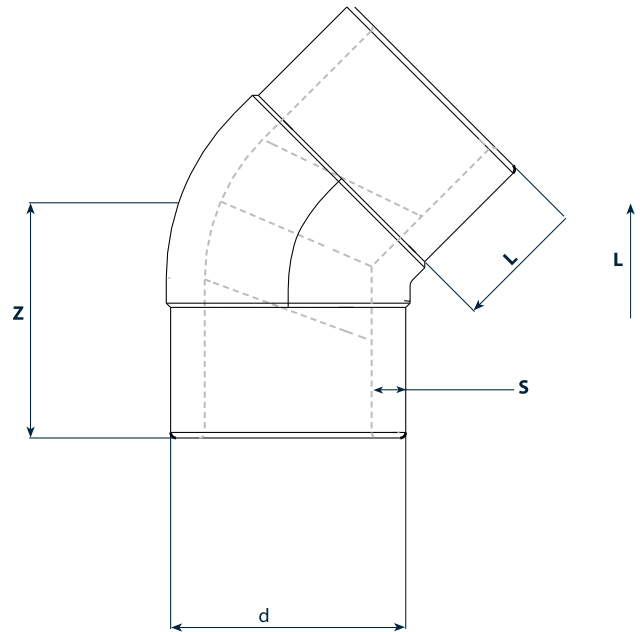
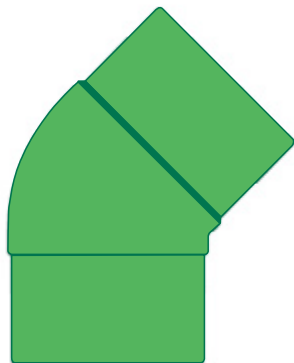
\*T.B.A\*: To be Announced.



## 45° ELBOW CLASS 2\*

API Code	d	S	L	I
T.B.A	160	21.9	90	135

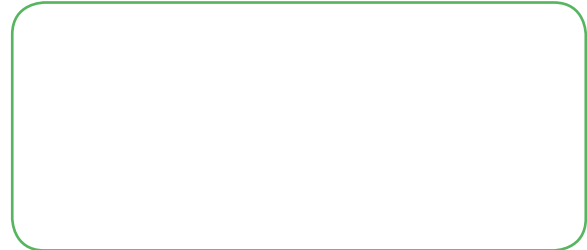
\*T.B.A\*: To be Announced.





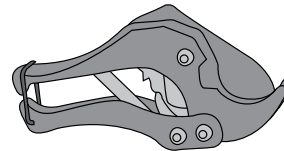
## WELDING MACHINE

API Code	Description		
2301000	Small	WM	800W
2301050	Big	WM	1200W
2305700	Bench	WM	Ø 29/20
2305800	Bench	WM	Ø 125/20



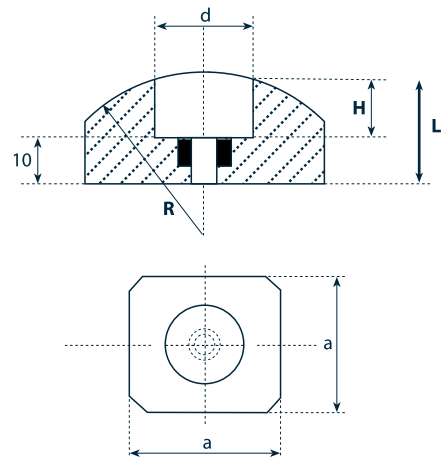
## PIPE CUTTERS

API Code	D
2303400	20/40
2303600	20/63



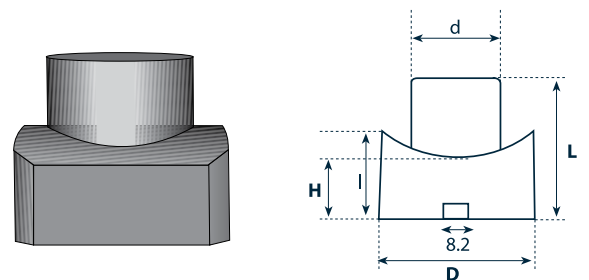
## SADDLE (FEMALE) SOCKET

API Code	Size	d	R	H	L	a
2304630	63-32	31.8	31.5	13.5	28.8	50
2304730	75-32	31.8	37.5	16	30.5	50
2304740	75-40	39.6	37.5	18	34.5	58
2304830	90-32	31.8	45	19	32.5	50
2304840	90-40	39.6	45	19	34	58
2304960	110-63	62.5	55	29	48.5	80



## SADDLE (FEMALE) SOCKET

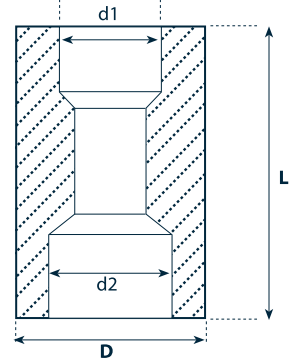
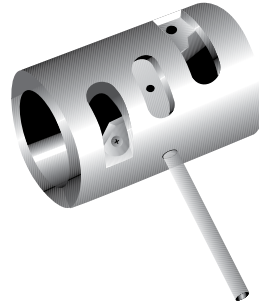
Size	d	D	I	L	H
63-32	31.5	42	26.5	39.6	19
75-32	31.5	42	23	40	17
75-40	39.4	55	29	45.5	17.5
90-32	31.5	41	23	39.5	18
90-40	39.4	55	27.5	45.5	18
110-63	84.4	51.5	39.5	59.5	20



# PRODUCT RANGE

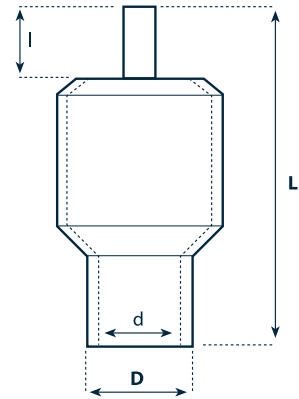
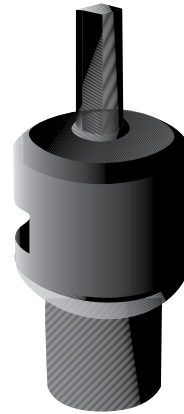
## ALU-PIPE® PEELER (MANUAL)

API Code	Size	d1	d2	D	L
2302012	20/25	22.45	27.6	50	94.4
2302034	32/40	34.65	42.9	65	94.4
2302056	50/63	52.9	66	88	109.5



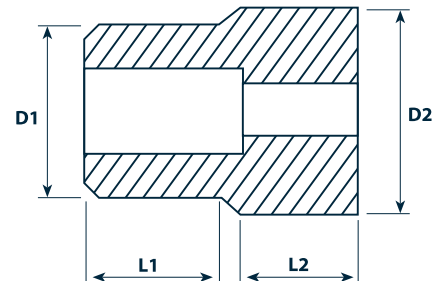
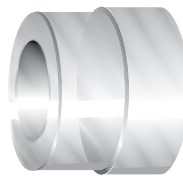
## ALU-PIPE® PEELER (ELECTRIC)

API Code	Size	d	D	l	L
2302110	20	22.45	27.9	30	96
2302120	25	27.6	34	30	98
2302130	32	34.65	41	30	100.1
2302140	40	42.9	50	30	102.2
2302150	50	52.9	60	30	105.1
2302160	63	66	74.1	30	109
2302170	75	78	86	30	112



## CALIBRATION TOOLS FOR PEELERS

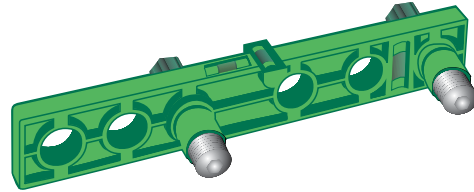
API Code	Size	d	D	l	L
2302210	20	20.30	22.35	15	12
2302220	25	25.35	27.55	15	12
2302230	32	32.35	34.55	15	12
2302240	40	40.35	42.85	15	12
2302250	50	50.40	52.85	15	12
2302260	63	63.50	65.95	15	12
2302270	75	75.50	78.0	15	12



## LEVELER

API Code

2400003



## REPAIR SOCKETS

API Code

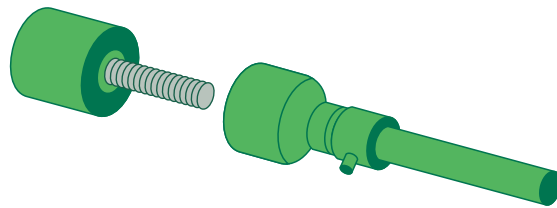
D

2400007

7

2400011

11



# PRODUCT RANGE



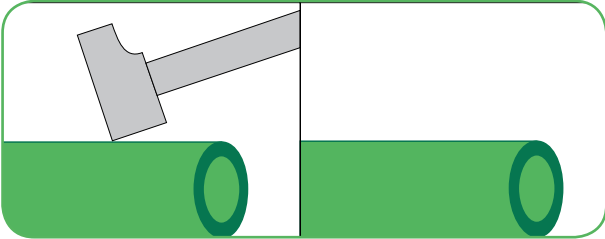
PIPES

100

# HANDLING PLASTIC PIPES AND FITTINGS

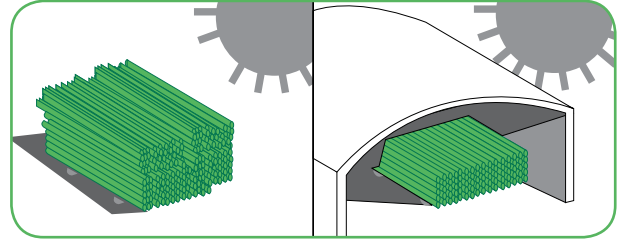
**WRONG**

**RIGHT**



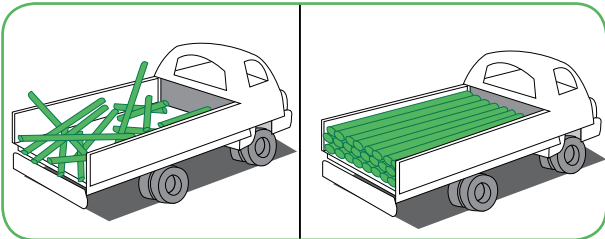
**WRONG**

**RIGHT**



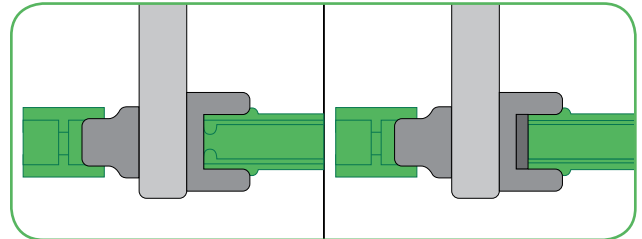
**WRONG**

**RIGHT**



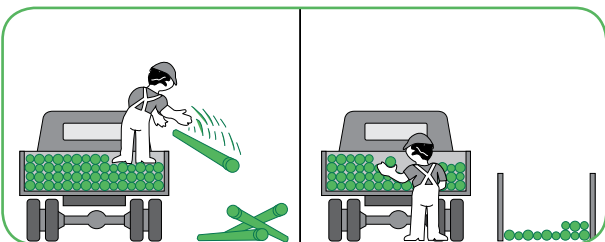
**WRONG**

**RIGHT**



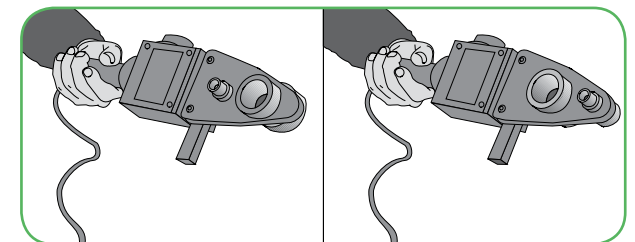
**WRONG**

**RIGHT**



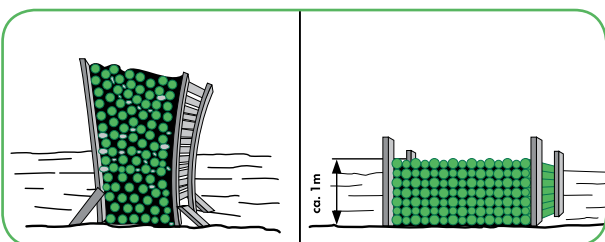
**WRONG**

**RIGHT**



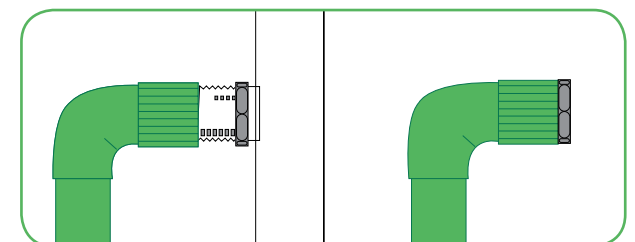
**WRONG**

**RIGHT**



**WRONG**

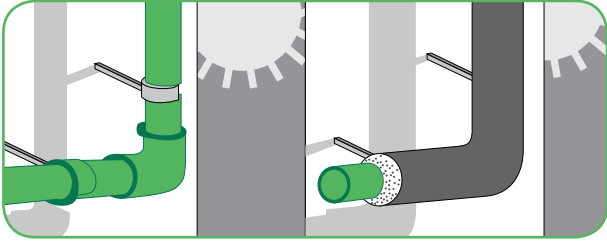
**RIGHT**



# HANDLING PLASTIC PIPES AND FITTINGS

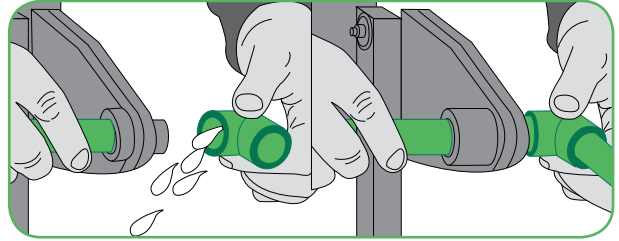
**WRONG**

**RIGHT**



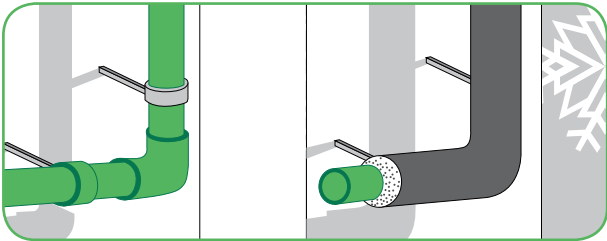
**WRONG**

**RIGHT**



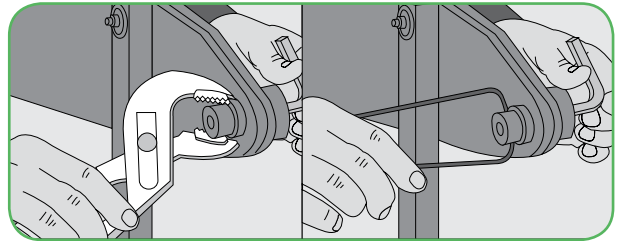
**WRONG**

**RIGHT**



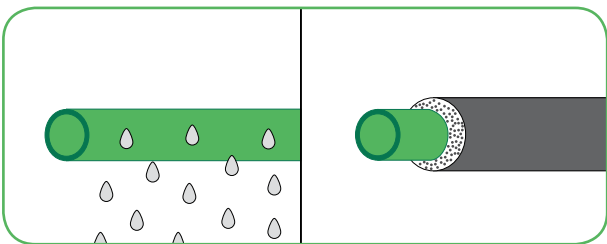
**WRONG**

**RIGHT**



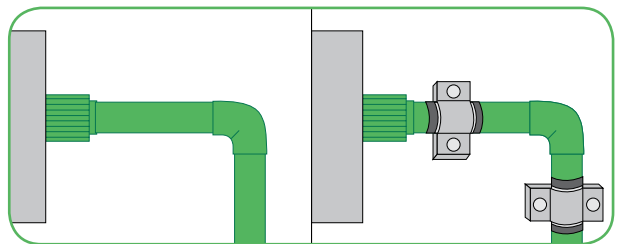
**WRONG**

**RIGHT**



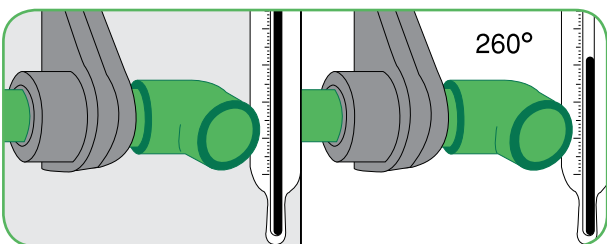
**WRONG**

**RIGHT**



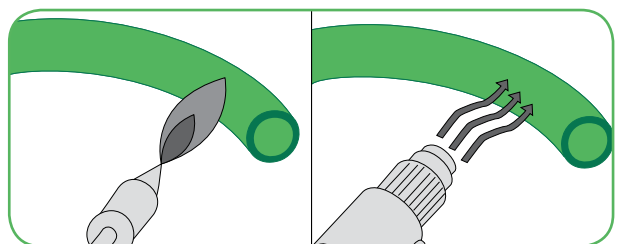
**WRONG**

**RIGHT**



**WRONG**

**RIGHT**



PIPES

TABLE

Chemicals	Conc. %	Polypropylene		
		20	C 60	100
<b>A</b>				
Acetic acid (Glacial acetic acid)	100	+	0	-
Acetic acid aq. (see also vinegar)	50 10	+	+	+
Acetic anhydride	100	+		
Acetone (Boiling point 56.3 C)	100	+	0	
Alcoholic iodine		+		
Alum	sat.	+	+	
Alums aq.	any	+	+	
Aluminium salts aq.	any	+	+	+
Ammonia, gaseous	100	+	+	
Ammonia aq.	conc.	+	+	
	10	+	+	
Ammonium acetate aq.	any	+	+	+
Ammonium carbonate aq.	any	+	+	+
Ammonium chloride aq.	any	+	+	+
Ammonium nitrate aq.	any	+	+	+
Ammonium phosphate aq.	any	+	+	+
Ammonium sulphate aq.	any	+	+	+
Amyl alcohol, pure (fermentation amyl alcohol)		+	+	
Aniline	100	+	(+)	
Antifreeze agent (cars)**		+	+	
Apple juice		+	+	
Apple sauce		+	+	(+)
Aqua regia		+	-	
Asphalt**		+	0	
ASPIRIN®		+		

Resistances + = resistant  
 (+) = practically resistant  
 0 = of limited chemical resistance  
 (0) = poorly resistant  
 - = not resistant

Concentrations aq. = aqueous  
 sat. = saturated at room temperature  
 c = coloured

\*\*Chemical resistance depends upon the composition

# CHEMICAL RESISTANCE

TABLE

Chemicals	Conc. %	Polypropylene		
		20	C 60	100
<b>B</b>				
Barium salts	any	+	+	+
Beef suet		+	+	
Beer		+		
Benzaldehyde	100	+		
Benzaldehyde aq.	sat. (0.3)	+		
Benzene	100	(-)	-	
Benzoic acid	100	+	+	
Benzoic acid aq.	sat.	+	+	+
Bleaching solution (12.5% active chlorine)		0	0	
Bone oil		+	(+)	
Borax aq.	sat.	+	+	
Boric acid	100	+	+	
Boric acid aq.	sat. (4.9)	+	+	
Brake fluid**		+	+	
Brandy		+		
Bromine, liquid	100	-		
Bromine, vapours	high low	- 0	-	
Bromine water	sat.	-	-	
Butane, gaseous	100	+	+	
Butane, liquid	100	+		
Butter		+	+	
Buttermilk		+		
Butyl acetate	100	+	0	
n-Butyl alcohol (n-butanol)	100	+	+	
<b>C</b>				
Cake		+	+	(+)
Calcium chloride aq.	sat.	+	+	+
Calcium nitrate aq.	sat.	+	+	
Camphor		+		
Carbon bisulphide (Boiling point 46.2 C)	100	0		
Carbon tetrachloride	100	+	-	
Caustic potash solution	50	+	+	



TABLE

Chemicals	Conc. %	Polypropylene		
		20	C 60	100
<b>C</b>			t	
	25	+	+	
	10	+	+	+
Cheese		+		
Chloride of lime (aqueous suspension)		+	+	
Chlorine, gas, dry	100	-	-	-
Chlorine, gas, humid	10	0	-	-
Chlorine, liquid	100	-		
Chlorine water	sat.	0	-	
Chlorobenzene	100			
Chloroform	100	(-)	-	
Chlorosulphonic acid	100	-	-	
Chromic acid	sat. 20	+ +	- 0	
Chromic/ sulphuric acid		-	-	
Chromium plating solution**		+	+	
Chromium salts (bi- and trivalent) aq.	sat.	+	+	
Cinnamon (cane)		+		
Cinnamon (ground)		+		
Citric acid aq.	sat.	+	+	+
Clove oil		+	0	
Cloves				
Coca-Cola		+		
Cocoa (powdered)		+		
Cocoa (ready to drink)		+	+	(+)
Coconut oil		+	(+)	
Cod-liver oil		+	+	
Coffee (beans and ground)		+		
Coffee (ready to drink)		+	+	+
Common salt, dry		+	+	+
Copper salts aq.	sat.	+	+	+
Corn seed oil		+	0	
Cream, whipped cream		+		
Cresol solution		+		
Cresol	100	+	0	
<b>D</b>				
Decahydronaphtalene	100	0	-	-
Detergents, synthetic** (without solvents, plasticizers and other additives)	High ready for use	+	+	

# CHEMICAL RESISTANCE

TABLE

Chemicals	Conc. %	Polypropylene		
		20	C 60	100
<b>D</b>				
Dibutylphthalate (see plasticizers)				
Diesel oil (see Fuels)				
Dimethylformarnide	100	+		
1,4-Dioxane	100	+	0	-
Dish-washing agents.** (liquid)	+	+	+	
DIXAN solution (ready for use)	ready	+	+	+
<b>E</b>				
Eggs (uncooked and cooked)		+	+	(+)
Ether (Diethyl ether)**	100	0		
Ethyl acetate	100	0	0	
Ethyl alcohol not denatured	100	+		
Ethyl alcohol aq. not denatured	96	+	+	
	50	+	+	
	10	+	+	
Ethyl benzene	100	0	-	
Ethyl chloride**	100	-		
Ethylene chloride	100	0	(-)	
2-Ethyl hexanol	100	+		
<b>F</b>				
Fixing salt (see Sodium Thiosulphate)	10	+	+	
Floor wax**		+	0	
Flour		+		
Fluoric acid	40	+	+	
Formaldehyde aq.	40	+	+	
GhC	30	+	+	
	10	+	+	
FORMALIN		+	+	
Formic acid	98	+	0	
	90	+		
	50	+	+	
	10	+	+	+
Fruit juice		+	+	
Fruit salad		+		
Fuel				
Petrol, normal (DIN 51 635)		+	0	
Petrol, regular		(+)	-	
Petrol, super		0	-	
Diesel oil**		+	0	
Fuel oil**		+	0	

TABLE

Chemicals	Conc. %	Polypropylene		
		20	C 60	100
<b>G</b>				
Gin	40	+		
Glycerine	100	+	+	
Glycerine aq.	high low	+	+	+
Glycol	100	+	+	
Glycol aq.	high low	+	+	+
Grapefruit juice		+	+	
Gravy		+	+	(+)
<b>H</b>				
Hair shampoo**		+	+	
Heptane	100	+	0	
Hexane	100	+	0	
Honey		+	+	
Horse-radish, ready-to-eat		+		
Hydrolic acid	conc.	+	+	
	10	+	+	
Hydrogen chloride, gaseous (see also Hydrochloric acid)	high low	+	+	
		+	+	
Hydrogen peroxide aq.	90 30 10 3		0 + +	
		+	+	+
Hydrogen sulphide (Colouration with lead stabilizers)	low	+	+	
<b>I</b>				
Ink**		+	+	
Iron salts aq.	sat.	+	+	+
Isooctane	100	+	0	
Isopropyl alcohol	100	+	+	
<b>J</b>				
Jam		+	+	(+)
Jelly		+	+	(+)
<b>L</b>				
Lactic acid aq.	90 50 10	+	+	
		+	+	+
LANOLIN		+	0	
Lard		+	+	0

# CHEMICAL RESISTANCE

TABLE

Chemicals	Conc. %	Polypropylene		
		20	C 60	100
Lemonades		+		
Lemon aroma			+	
Lemon juice		+	+	
Lemon peel		+		
<b>M</b>				
Magnesium salts aq.	sat.	+	+	+
Margarine		+	+	
MARLIPAL® MG	50	+	+	
MARLON®		+	+	
(42% active detergent)	100	+		
MARLOPHEN® 83	20	+		
MARLOPHEN 89	100	+		
	5	+		
MARLOPHEN 810	100	+		
	20	+		
	5	+		
MARLOPHEN 820	100	+		
	20	+	+	
	5	+	+	
Mashed potatoes		+	+	(+)
Mayonnaise		+		
Menthol		+		
Mercuric salts aq.	sat.	+	+	
Mercury	100	+	+	
Methyl alcohol	100	+	+	
Methyl alcohol aq.	50	+	+	
Methylene chloride (Boiling point 40,7 C)	100	0		
Methyl ethyl ketone	100	+	0	
Milk		+	+	(+)
Milk food		+	+	(+)
Mineral oil** (without aromatic hydrocarbons)		+	0	-
Moth balls**		+		
Motor oil (cars)**		+	0	-
Mustard		+		

TABLE

Chemicals	Conc. %	Polypropylene		
		20	C 60	100
<b>N</b>				
Nail polish (BP 40,7 C)		+	0	
Nail polish remover (BP 40,7 C)		+	0	
Naphtalene	100	+		
Nickel salts aq.		+	+	
Nitric acid	50	0	-	
	25	+	+	
	10	+	+	
Nitrobenzene	100	0	0	
<b>O</b>				
Octane (see Isooctane)				
Oil No. 3 according to ASTM D 380-59	100	+	0	-
<b>P</b>				
Palm oil		+	0	
Paprika		+	+	
Paraffin	100	+	+	-
Paraffin oil	100	+	0	-
Peanut oil		+	(+)	(-)
Pectin	sat.	+	+	
Pepper		+	+	
Peppermint oil		+		
Perchlorethylene (see Tetrachlorethylene)				
Perfume (the permeability for scents should be considered)		+		
Petrol (see Fuels)				
Menthol		+		
Petroleum	100	+	0	
Petroleum ether	100	+	0	
Phenol (aqueous phase)	sat.	+	+	
(phenolic phase)	sat.	+		
Phosphoric acid	sat. (85)	+	0	
	50	+	+	
	10	+	+	+
Phosphorus pentoxide	100	+		
Photographic developers**	comm. ready for use	+	+	
		+	+	
Pine needle oil	100	+	(+)	
Plasticizers				

# CHEMICAL RESISTANCE

TABLE

Chemicals	Conc. %	Polypropylene		
		20	C 60	100
<b>P</b>				
Dibutylphthalate (VESTINOL® C)		+	0	
Dibutylsebecate		+		
Diethylphthalate		+		
Dinonylaidpate		+		
Disononylphthalate (VESTINOL H)		+		
Diethylphthalate (VESTINOL AH)		+		
Tricresylphosphate		+		
Tricetylphosphate		+		
Porridge		+	+	(+)
Potassium carbonate aq. (Potash)	sat.	+	+	
Potassium chlorate aq.	sat. (7.3)	+	+	
Potassium chloride aq.	sat.	+	+	+
Potassium dichromate	sat. (12)	+	+	+
Potassium iodide aq.	sat.	+	+	
Potassium nitrate aq.	sat.	+	+	
Potassium permanganate aq.	sat. (6.4)	+	(+)	
<b>Q</b>				
Quinine		+		
<b>R</b>				
Rum	40	+	+	
<b>S</b>				
SAGROTAN		0	0	
Salad oil, animal	+	0		
Salad oil, vegetable	+	+		
Salted water	any	+	+	+
Sea water		+	+	+
Shoe polish**		+	0	
Silicone oil**		+	(+)	
Silver salts aq.	sat.	+	+	
Soap, cake soap		+	+	
Soap solution	sat. 10	+	+	+
Soda (see Sodium carbonate)				
Soda water		+		
Sodium bicarbonate aq.	sat.	+	+	+
Sodium bisulphite aq.	sat.	+	+	
Sodium carbonate aq.	sat. 10	+	+	+

TABLE

Chemicals	Conc. %	Polypropylene		
		20	C 60	100
<b>S</b>				
Sodium chlorate aq.	25	+	+	
Sodium chloride aq. (common salt)	sat.	+	+	+
Sodium chlorite aq.	5	+		
Sodium hydroxide (Caustic soda)				
Sodium hypochlorite aq.	5	+	+	
Sodium nitrate aq.	sat.	+	+	
Sodium nitrite aq.	sat.	+		
Sodium perborate aq.	sat. (1.4)	+	+	+
Sodium phosphates aq.	sat.	+	+	+
Sodium sulphate aq. (Glauber's Salt)	sat.	+	+	+
Sodium sulphide aq. (colouration with lead stabilizers)	sat.	+	+	
Sodium sulphite aq.	sat.	+	+	
Sodium thiosulphite aq. (photographic fixer)	sat.	+	+	+
Soft soap		+	+	
Soybean oil		+	0	
Stannous chloride	sat.	+	+	
Starch, starch solution aq.	any	+	+	
Stearic acid	100	+		
Storage-battery acid		+	+	
Succinic acid aq.	sat.	+	+	
<b>T</b>				
Tar		+	0	
Tartaric acids aq.	sat.	+	+	
Tea (leaves)		+	+	
Tea (Ready-to-drink)		+	+	(+)
Tetrachlorethane	100	(-)	-	
Tetrachlorethylene (Perchlorethylene)	100	0	-	
Tetrahydrofuran GhC	100	0	-	
Tetrahydronaphtalene	100	0	-	
Thick (semolina) gruel		+	+	(+)
Thiophene	100	0	-	
Toluene	100	0	-	
Tomato juice		+	+	
Tomato ketchup		+	+	
Toothpastes		+	+	

# CHEMICAL RESISTANCE

TABLE

Chemicals	Conc. %	Polypropylene		
		20	C 60	100
<b>T</b>				
Tar		+	0	
Tartaric acides aq.	sat.	+	+	
Tea (leaves)		+	+	
Tea (Ready-to-drink)		+	+	(+)
Tetrachlorethane	100	(-)	-	
Tetrachlorethylene (Perchlorethylene)	100	0	-	
Tetrahydrofuran GhC	100	0	-	
Tetrahydronaphtalene	100	0	-	
Thick (semolina) gruel		+	+	(+)
Thiophene	100	0	-	
Toluene	100	0	-	
Tomato juice		+	+	
Tomato ketchup		+	+	
Toothpastes		+	+	
Transfomer oil**	+	0		
Trichlorethylene	100	0	(-)	
Turpentine oil		0	-	
Two-stroke oil		0	0	
Typewriter oil		+	(+)	
<b>U</b>				
Urea aq.	sat.	+	+	



TABLE

Chemicals	Conc. %	Polypropylene		
		20	C 60	100
<b>V</b>				
Vanilla		+	+	
Vaseline		+	0	
Vegetables (ready-to-eat)		+	+	(+)
Vinegar	comm.	+	+	
Vinegar essence	comm.	+	+	
(here is referred to a 50% concentration)				
<b>W</b>				
Water	100	+	+	+
Water glass		+	+	
Whisky	40	+		
White spirit		+	0	
Wine, mulled claret		+	+	
<b>X</b>				
Xylene	100	0	-	
<b>Z</b>				
Zinc salts aq.	sat.	+	+	

# SYSTEM INSPECTION & TESTING

## TABLE

Upon completion a section of or the entire water supply system, the system, or portion completed, shall be inspected and proved tight under water pressure. The inspection must take place before embedding or concealing the system under concrete or in walls. This requirement is important to allow for preventative maintenance of the system if deemed necessary during system inspection.

For APITHERM pipe, the inspection process is broken down in two sections: visual and operational.

### VISUAL INSPECTION:

Visual inspection: A visual inspection should cover, but not limited to the following basic steps:

- 1- No pipe shall be secured to another pipe or used as a support for other pipes.
- 2- Pipes shall be laid as to prevent the formation of air locks or pockets.
- 3- Where pipes are laid above one another, cold water pipes shall be installed under hot water pipes to prevent condensation.
- 4- The supply pipes for each floor and those in individual flats shall be capable of being shut separately.
- 5- All inlets and outlets of completed pipe work shall be tightly closed with stoppers or caps to prepare for operational phase of the system inspection.

### OPERATION INSPECTION:

#### INSPECTION NOTES:

- 1-Owing to their material properties, Apitherm pipes expand when subjected to pressure, which in turn might influence the Operational Inspection.
- 2-The operational test is also susceptible to pipe wall temperature; a change in temperature of 10 C corresponds to a pressure change of 0.5 to 1 bar. Thus the test medium and the ambient temperature shall, if possible, be kept at constant temperature throughout the inspection phase. Operational inspection procedure: the visually inspected pipe work shall be filled with fresh water and completely vented. The presence of air pockets in the system will lead to premature explosive failure of the system with dangerous consequences to human life near the failure point.

The operational phase of the inspection shall be carried out in two stages:

- 1-For the first stage, a test pressure equal to the permissible working pressure plus 10 bar shall be produced twice within 30 minutes at 10-minute interval. Then it shall be checked whether, over an additional period of 30 minutes, the pressure has dropped by more than 0.6 bar and leakage has occurred.
- 2-The second stage shall follow the first stage without interval and shall last 24 hours at a pressure of 15 bar. Then, it shall be checked if the pressure has dropped by more than 0.2 bar and the pipe work shows any signs of leakage.

## TABLE

**This specification covers requirements for polypropylene random (PP-r) piping system (pipe and fittings) for sanitary applications intended for hot and cold-water installations as well heating systems.**

### APPROVED MANUFACTURER:

The pipe and fitting manufacturer shall have an established quality control program responsible for inspecting incoming and outgoing materials. The manufacturer shall have a document control procedure, which allows for traceability of manufactured products... It is mandatory for the manufacturer to be operating and producing under ISO9001: 2000 quality requirements.

### 1. POLYPROPYLENE PIPES:

All PP-r pipes shall be manufactured from 100% approved virgin raw material in accordance with EN-ISO 15874 (DIN 8078) and /or prEN 12202-Part 2.

Produced pipes must be rated Class2 (PN20) or Class5 (PN25) wall thickness. Mechanical Characteristics, mean outside diameter and out of roundness together with their tolerances must comply with Din 8077, prEN 12202-Part 2 and / or LN511. Exposed pipes installations intended for transporting hot water must be rated Class 2 (PN20) or Class 5 (PN25) and heat stabilized with aluminum foils.

### PIPES PACKAGING:

All pipe sizes will be supplied in straight lengths of 4 m each. Packaging of pipes will differ according to size.

### MARKING OF PIPES:

All pipes shall bear permanent identification markings that will remain legible during the service life of the product. marking on pipe shall include the following and shall be applied at intervals of not more than 1.5 meters:

- 1- Trademark and Nominal diameter and thickness (i.e. APITHERM 32 x 5.4).
- 2- Standard PP-r Designation (i.e. PPr 80 or PP-RCT)
- 3- The standard Dimension Ratio (i.e. SDR 5 or SDR 6) and application classes (Class 5).
- 4- Marking the product with the applicable Standards designation (i.e. DIN 8077/8078).
- 5- Quality System used (i.e. ISO 900x).
- 6- Date and Time of manufacture reference.
- 7- Manufacturer's name and country of manufacture.

### 2. POLYPROPYLENE FITTINGS:

All PP-r Fittings supplied under this scope of work must be pressure rated Class 5 and manufactured from the same material used to manufacture pipe and shall pass all tests required under DIN 16962/5 and / or PrEN 12202- Part 3.

### FITTING INSERTS:

All inserts used in the in the manufacturing of threaded fitting of threaded fittings must be made of dezincification Resistant Brass. All threads must be made according to DIN 2999. All male threads must be serrated to ease the application of sealing tape. Male threaded fittings must have PP-r coverage extending to the tip of the insert (on the inner surface).

### MARKING OF FITTINGS:

All fittings shall have permanent identification markings indicating the following:

- 1- Trademark, size and pressure rating of fitting (Class5)
- 2- Standard PP-r designation (i.e. PPr 80 or PP-RCT)
- 3- Day and Year Stamp indicating period of manufacturing
- 4- Manufacturer's Quality Control

# GUARANTEE

OUR LOCAL GUARANTEE

SYSTEM INSPECTION

# GUARANTEE

OUR LOCAL GUARANTEE



# GUARANTEE

## OUR LOCAL GUARANTEE

SYSTEM INSPECTION

118



### Advanced Plastic Industries SAL.

Industrial Zone, Zouk Mosbeh-Lebanon

*Bureau Veritas Certification certify that the Management System of the above organisation has been audited and found to be in accordance with the requirements of the management system standards detailed below*

#### Standards

## ISO 9001:2008

#### Scope of Certification

**Manufacturing of Polypropylene (PP) & Polypropylene Random (PP-RCT & PP-R) Pipes and Fittings & Manufacturing of Polyethylene (PE) Pipes and Fittings**

Certification cycle start date: **18<sup>th</sup> March 2014**

Subject to the continued satisfactory operation of the organisation's Management System, this certificate expires on: **18<sup>th</sup> March 2017**

Original certification date: **16<sup>th</sup> December 1998**

Certificate No. **IND 14.7162 U/Q**

Version **1, 10<sup>th</sup> March 2014**

  
**Certification Manager**



Certification body address: **Brandon House, 180 Borough High Street, London SE1 1LH, United Kingdom**  
Local office: **Bureau Veritas Liban SAL – Dedeyan Center 9<sup>th</sup> Floor – Dora - Lebanon**

008

Further clarifications regarding the scope of this certificate and the applicability of the management system requirements may be obtained by consulting the organisation.  
To check this certificate validity please call: **961 1 240540 / 640**



# ZERTIFIKAT — SKZ

## Certificate

SKZ - TeConA GmbH awards the following company

**Advanced Plastic Industries (API) s.a.l.**  
**Fares Tabet Building,**  
**Old NDU campus road,**  
**Zouk Mosbeh, Kesrouan**  
**LEBANON**

the right to use the SKZ - testing and inspection mark



**A 523**

for the following plastic products

**Pressure pipes, group 1 and group 2**  
**Pipes made of polypropylene PP-RCT**

**SKZ specification for tests and inspection HR 3.34: 2006-01**

Users of the SKZ - mark are obliged to observe the required regulations for the production and testing of these products.

Date of expiry: 13 September 2014

Würzburg, 14 September 2009



*Lamb*  
-----  
Certification body

# GUARANTEE

## OUR LOCAL GUARANTEE

**TZW**  
Prüfstelle Wasser

### PRÜFZEUGNIS

über die Untersuchung von Rohrproben PP-RCT, grün (SKZ A 523) gemäß der KTW-Leitlinie des Umweltbundesamtes (UBA)

Überwachungszeitraum: Überwachungsprüfung 2011  
 Hersteller: Advanced Plastic Industries s.a.l., P.O. Box 2161 Jounieh, Libanon  
 Abmessung: 25 x 3,5 mm  
 Materialbezeichnung: [Borealis RA 7050 GN]  
 Eingang der Proben: 03.11.2011  
 Probenehmer: SKZ, H. Pfeuffer am 26.10.2011, SKZ-Nr. 4768  
 TZW-Az.: KR 252/11

#### Untersuchungsergebnisse

1. Rezeptur: wurde unter KC 074/11 vorgelegt und überprüft
2. Werkstoffnachweis nach DVGW-Arbeitsblatt W 270: Untersuchungsbericht TZW-Az.: MO 025/11 vom 08.02.2011
3. Migrationstest:

Kaltwasser 23°C	1. – 3. Tag	4. – 6. Tag	7. – 9. Tag	Richtwert für 3. Extraktion
Klarheit, Färbung, Geruch, Geschmack, Schaumbildung	n nb	n nb	n nb	nicht nennenswert beeinflusst
C-Abgabe [mg C/m²d]	< 0,2	< 0,2	< 0,2	≤ 2,5
Cl <sub>2</sub> -Zehrung [mg Cl <sub>2</sub> /m²d]	0,9	0,3	0,2	

Warmwasser 60°C	1. Extr.	2. Extr.	3. Extr.	6. Extr.	7. Extr.	Richtwert für 7. Extr.
Klarheit, Färbung, Geruch, Geschmack, Schaumbildung	n nb	n nb	n nb	n nb	n nb	≤ 4
C-Abgabe [mg C/m²d]	0,6	0,9	0,9	< 0,5	< 0,5	≤ 2,5

Die untersuchten Rohrproben PP-RCT, grün entsprechen den Anforderungen der KTW-Leitlinie des Umweltbundesamtes (Bgesundhbl. 2005).

Karlsruhe, den 06.12.2011

  
 Dr. J. Klinger  
 Leiter der Prüfstelle

Die Veröffentlichung des Prüfzeugnisses – vollständig oder in Auszügen – ist ohne ausdrückliche Genehmigung von seiten der Prüfstelle nicht gestattet

Das Technologiezentrum Wasser ist eine  
 Einrichtung des DVGW Deutscher Verein  
 des Gas- und Wasserfaches e. V.  
 – Technisch-wissenschaftl. Verein –

Technologiezentrum Wasser  
 Prüfstelle Wasser  
 Wasserwerkstraße 4  
 76137 Karlsruhe, Germany

T +49 (0)721 9 31 63-0  
 F +49 (0)721 3 31 60  
 pruefstelle@tzw.de, www.tzw.de





Industrial Zone - Zouk Mosbeh, Lebanon - P.O. Box 2161 Jounieh

T +961 9 220 857/8/9

F +961 9 220 860

E [contact@api.com.lb](mailto:contact@api.com.lb)

[www.api.com.lb](http://www.api.com.lb)